

**HP 8935 Series  
E6380A CDMA Cellular/PCS Base Station Test Set  
and E6381A TDMA Base Station Test Set**

**Programmer's Guide**

**Firmware Version:  
E6380A - A.01.10 and above  
E6381A - A.01.00 and above**

HP Part Number E6380-90018

**Revision B  
Printed in U.S.A.**

**June 1998**



---

## **Notice**

Information contained in this document is subject to change without notice.

All Rights Reserved. Reproduction, adaptation, or translation without prior written permission is prohibited, except as allowed under the copyright laws.

This material may be reproduced by or for the U.S. Government pursuant to the Copyright License under the clause at DFARS 52.227-7013 (APR 1988).

© Copyright 1997 Hewlett-Packard Company

## About this manual, its companions, and product regulatory information.5

What is discussed in this manual . . . . .	5
Where to find other information . . . . .	5
Conventions Used in This Manual . . . . .	5
Which Document is Required? . . . . .	6
Regulatory Information . . . . .	7
Safety . . . . .	7
WARNING - RUBIDIUM REFERENCE ASSEMBLY (E6381A) . . . .	12
Hewlett-Packard Warranty Statement for Commercial Products . . .	13
ASSISTANCE . . . . .	14
Regional Sales Offices . . . . .	15

### 1. Using HP-IB

Overview of the Test Set . . . . .	18
Getting Started . . . . .	26
Remote Operation . . . . .	39
Addressing . . . . .	41
IEEE 488.1 Remote Interface Message Capabilities . . . . .	42
Remote/Local Modes . . . . .	48

### 2. Methods For Reading Measurement Results

Background . . . . .	52
HP BASIC 'ON TIMEOUT' Example Program . . . . .	54
HP BASIC 'MAV' Example Program . . . . .	58

### 3. HP-IB Command Guidelines

Sequential and Overlapped Commands . . . . .	64
Guidelines for Operation . . . . .	65

### 4. IEEE Common Commands

IEEE 488.2 Common Commands . . . . .	88
Common Command Descriptions . . . . .	89

### 5. Triggering Measurements

Triggering Measurements . . . . .	104
-----------------------------------	-----

### 6. Advanced Operations

Increasing Measurement Throughput . . . . .	114
Status Reporting . . . . .	122
HP-IB Service Requests . . . . .	168
Instrument Initialization . . . . .	177
Passing Control . . . . .	187

### 7. Memory Cards/Mass Storage

Default File System . . . . .	198
Mass Storage Device Overview . . . . .	198

---

## Contents

Default Mass Storage Locations . . . . .	202
Mass Storage Access . . . . .	204
DOS File System Considerations . . . . .	205
Using the ROM . . . . .	208
Using PC Cards . . . . .	209
Backing Up Procedure and Library Files . . . . .	214
Copying Files Using IBASIC Commands . . . . .	215
Using RAM . . . . .	217
<b>8. IBASIC Controller</b>	
Introduction . . . . .	220
The IBASIC Controller Screen . . . . .	221
Important Notes for Program Development . . . . .	223
Program Development . . . . .	224
Interfacing to the IBASIC Controller using Serial Ports . . . . .	226
Choosing Your Development Method . . . . .	238
Method #1. Program Development on an External BASIC Language Computer . . . . .	240
Method #2. Developing Programs on the Test Set Using the IBASIC EDIT Mode . . . . .	247
Method #3. Developing Programs Using Word Processor on a PC (Least Preferred) . . . . .	251
Uploading Programs from the Test Set to a PC . . . . .	259
Serial I/O from IBASIC Programs . . . . .	260
PROGram Subsystem . . . . .	263
The TESTS Subsystem . . . . .	287
<b>9. Error Messages</b>	
General Information About Error Messages . . . . .	294
HP-IB Errors . . . . .	300
Text Only HP-IB Errors . . . . .	301
Numbered HP-IB Error Descriptions . . . . .	303

---

# About this manual, its companions, and product regulatory information.

## What is discussed in this manual

This manual explains how to program the Test Set.

This document presents the information needed to perform IBASIC programming operations, such as writing, editing, copying, or cataloguing programs.

## Where to find other information

HP-IB syntax used to write programs for the Test Set is found in the *HP-IB Syntax Reference Guide*.

The IBASIC language is explained in the *HP Instrument BASIC User's Handbook* (HP part number E2083-90005).

A step-by-step approach to base station testing using the Test Set, including what you need to know before you can start testing is found in the Application Guides. These guides each cover a specific technology or radio system.

General operation of the Test Set (such as changing display screens and using their associated controls) is discussed in the *Reference Guide*. The *Reference Guide* also describes the Test Set's keys, connectors and display screens, and the measurements that the Test Set can perform.

Each manufacturer and cellular service provider has their own cell site control and base station configuration procedures that go beyond the scope of this documentation. You must refer to the manufacturer's documentation for information about controlling the base station, switching system, or any other software or hardware associated with your cell site equipment.

## Conventions Used in This Manual

The following conventions are used throughout this manual to help clarify instructions and reduce unnecessary text:

**Test Set** refers to the HP 8935 Series E6380A CDMA Cellular/PCS Base Station Test Set and E6381A TDMA Base Station Test Set.

Test Set keys are indicated like this: **Preset**

Test Set screen information, such as a measurement result or an error message, is shown like this: TX Channel Power -1.3 dBm

## Which Document is Required?

The following documents are part of the Test Set's family's document library. Use the table to help you decide which documents you need. Some of the documents are provided with the Test Set, others may be ordered separately.

**Table 1 HP 8935 (E6380A) Document Navigation**

<b>Documents</b>	<b>Part Number</b>	<b>Usage</b>
CDMA Application Guide	E6380-90016	Use this manual for basic CDMA measurements and for getting started with the Test Set.
AMPS Application Guide	E6380-90017	Use this manual for making AMPS base station measurements.
Reference Guide	E6380-90019	Use this manual for screen and field descriptions and general operation information about the Test Set.
Programmer's Guide	E6380-90018	Use this manual to learn how to write programs for the Test Set.
HP-IB Syntax Reference Guide	E6380-90073	Use this manual to learn HP-IB syntax for the Test Set.
Assembly Level Repair Guide	E6380-90015	Use this manual to perform calibration on the Test Set and for general service information.
CD-ROM	E6380-90027	All user documentation.

**Table 2 HP 8935 (E6381A) Document Navigation**

<b>Documents</b>	<b>Part Number</b>	<b>Usage</b>
AMPS Application Guide	E6381-90017	Use this manual for making AMPS base station measurements.
Programmer's Guide	E6380-90018	Use this manual to learn how to write programs for the Test Set.
Reference Guide	E6381-90019	Use this manual for general information on accessing and changing settings, general Test Set operation, connector descriptions, and error messages. It also contains information on loading and running the various automated test routines (RF Tools) built in to the Test Set.
Assembly Level Repair Guide	E6381-90015	Use this manual to perform calibration on the Test Set and for general service information.
HP-IB Syntax Guide	E6381-90014	Use this listing of HP-IB syntax when writing control programs for the Test Set.
CD-ROM	E6381-90020	All user documentation.

## Regulatory Information

### Manufacturer's Declaration

This statement is provided to comply with the requirements of the German Sound Emission Directive, from 18 January 1991.

This product has a sound pressure emission (at the operator position) < 70 dB(A).

Sound Pressure  $L_p < 70$  dB(A).

At Operator Position.

Normal Operation.

According to ISO 7779:1988/EN 27779:1991 (Type Test).

Herstellerbescheinigung

Diese Information steht im Zusammenhang mit den Anforderungen der Maschinenlärminformationsverordnung vom 18 Januar 1991.

Schalldruckpegel  $L_p < 70$  dB(A).

Am Arbeitsplatz.

Normaler Betrieb.

Nach ISO 7779:1988/EN 27779:1991 (Typprüfung).

## Safety

### GENERAL

This product and related documentation must be reviewed for familiarization with safety markings and instructions before operation.

This product has been designed and tested in accordance with IEC Publication 1010, *Safety Requirements for Electronic Measuring Apparatus*, and has been supplied in a safe condition. This instruction documentation contains information and warnings which must be followed by the user to ensure safe operation and to maintain the product in a safe condition.

### SAFETY SYMBOLS



Indicates instrument damage can occur if indicated operating limits are exceeded. Refer to the instructions in this guide.



Indicates hazardous voltages.



Indicates earth (ground) terminal

---

**WARNING**

**A WARNING note denotes a hazard. It calls attention to a procedure, practice, or the like, which, if not correctly performed or adhered to, could result in personal injury. Do not proceed beyond a WARNING sign until the indicated conditions are fully understood and met.**

---

---

**CAUTION**

A CAUTION note denotes a hazard. It calls attention to an operation procedure, practice, or the like, which, if not correctly performed or adhered to, could result in damage to or destruction of part or all of the product. Do not proceed beyond an CAUTION note until the indicated conditions are fully understood and met.

---

### **Safety Considerations for this Instrument**



---

WARNING



**This product is a Safety Class I instrument (provided with a protective earthing ground incorporated in the power cord). The mains plug shall only be inserted in a socket outlet provided with a protective earth contact. Any interruption of the protective conductor inside or outside of the product is likely to make the product dangerous. Intentional interruption is prohibited.**



**Do not expose to or operate this instrument in outdoor atmospheric conditions such as direct rain, hail, sleet, snow, icing, sunshine or wind. Operate this instrument only within its specified temperature humidity conditions.**



**This instrument is equipped with internal ground fault circuit interrupter class A.**

- **This device does not protect against electrical shock due to contact with both circuit conductors or a fault in supply wiring to product.**
  - **Do not use extension cord to connect this product to power receptacle. Attention-ne pas utiliser de rallonge pour raccorder le detecteur-disjoncteur a la prise de courant.**
  - **Replace cordset only with HP 8120 series. Attention - Remplacer uniquement par un cordon amovible numero 8120.**
  - **Do not use in wet location. Ne pas utiliser dans un emplacement mouille.**
-

---

**WARNING**

**Whenever it is likely that the protection has been impaired, the instrument must be made inoperative and be secured against any unintended operation.**

**If this instrument is to be energized via an autotransformer (for voltage reduction), make sure the common terminal is connected to the earth terminal of the power source.**

**If this product is not used as specified, the protection provided by the equipment could be impaired. This product must be used in a normal condition (in which all means for protection are intact) only.**

**No operator serviceable parts in this product. Refer servicing to qualified personnel. To prevent electrical shock, do not remove covers.**

**Servicing instructions are for use by qualified personnel only. To avoid electrical shock, do not perform any servicing unless you are qualified to do so.**

**The opening of covers or removal of parts is likely to expose dangerous voltages. Disconnect the product from all voltage sources while it is being opened.**

**Adjustments described in the manual are performed with power supplied to the instrument while protective covers are removed. Energy available at many points may, if contacted, result in personal injury.**

**The power cord is connected to internal capacitors that may remain live for 5 seconds after disconnecting the plug from its power supply.**

**For Continued protection against fire hazard, replace the line fuse(s) only with 250 V fuse(s) or the same current rating and type (for example, normal blow or time delay). Do not use repaired fuses or short circuited fuseholders. FUSE: T 5.0A**

---

---

**CAUTION**

Always use the three-prong ac power cord supplied with this product. Failure to ensure adequate earth grounding by not using this cord may cause personal injury and/or product damage.

This product is designed for use in Installation Category II and Pollution Degree 2 per IEC 1010 and IEC 664 respectively. For indoor use only.

This product has autoranging line voltage input, be sure the supply voltage is within the specified range.

**Ventilation Requirements:** When installing the product in a cabinet, the convection into and out of the product must not be restricted. The ambient temperature (outside the cabinet) must be less than the maximum operating temperature of the product by 4° C for every 100 watts dissipated in the cabinet. If the total power dissipated in the cabinet is greater than 800 watts, then forced convection must be used.

---

To prevent electrical shock, disconnect instrument from mains (line) before cleaning. Use a dry cloth or one slightly dampened with water to clean the external case parts. Do not attempt to clean internally.

**Product Markings**

**CE** - the CE mark is a registered trademark of the European Community. A CE mark accompanied by a year indicated the year the design was proven.

**CSA** - the CSA mark is a registered trademark of the Canadian Standards Association.

**WARNING -  
RUBIDIUM  
REFERENCE  
ASSEMBLY  
(E6381A)**

The optional Rubidium Reference assembly, A2A15, (OPTION AY5) of the HP 8935 Series E6381A TDMA Base Station Test Set contains the radioactive isotope Rubidium 87. DO NOT attempt to repair this assembly. This assembly contains no user serviceable parts. The Rubidium 87 is isolated inside a vacuum tube which is enclosed within a metal housing, and as a result, there is no measurable external radiation. The rubidium Reference assembly does not present any safety hazard. This assembly, for disposal purposes, is regulated as a hazardous waste and must be disposed of in accordance with local, state, and federal laws.

**FOR GROUND TRANSPORTATION IN THE U.S.A:**

This package conforms to the conditions and limitations specified in 49CFR 173.424 for radioactive material, excepted package - instruments, UN2910.

**FOR AIR TRANSPORTATION IN THE U.S.A AND INTERNATIONAL:**

This instrument must be shipped as cargo with the following endorsement in the nature and quantity of goods box on the air waybill, "Radioactive material, excepted package - instruments."

**Figure 1 Rubidium Transportation Labels**

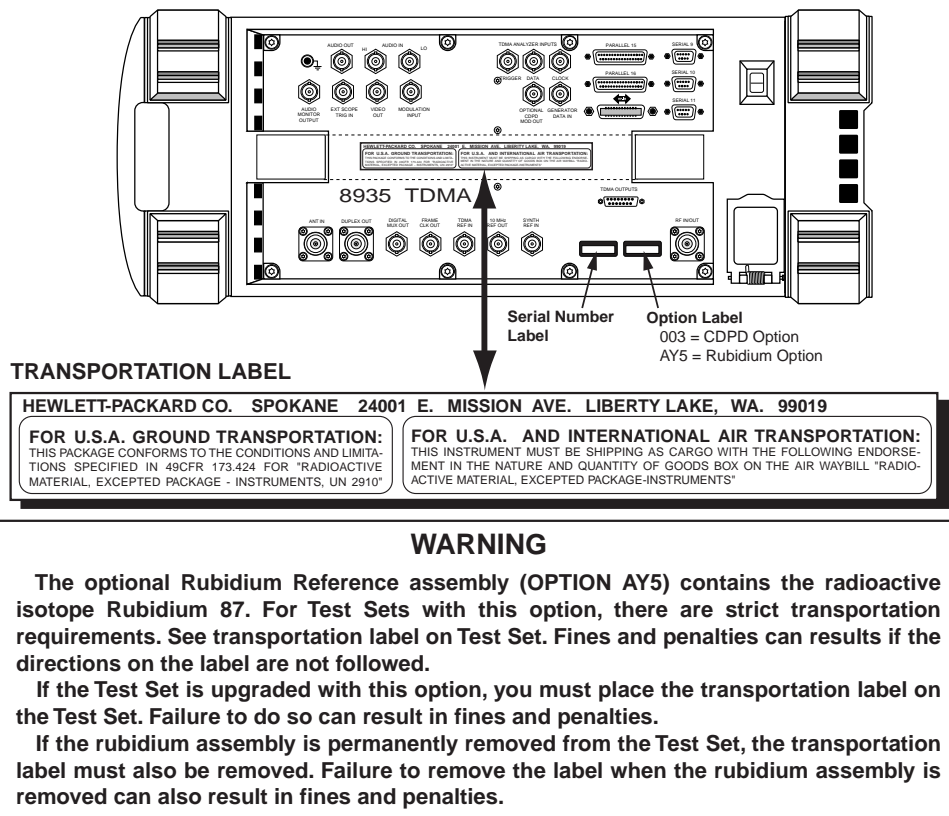

labels.eps

# **Hewlett-Packard Warranty Statement for Commercial Products**

**Product Name: E6380A/E6381A**

**Duration of Warranty: 1 year**

1. HP warrants HP hardware, accessories and supplies against defects in materials and workmanship for the period specified above. If HP receives notice of such defects during the warranty period, HP will, at its option, either repair or replace products which prove to be defective. Replacement products may be either new or like-new.
2. HP warrants that HP software will not fail to execute its programming instructions, for the period specified above, due to defects in material and workmanship when properly installed and used. If HP receives notice of such defects during the warranty period, HP will replace software media which does not execute its programming instructions due to such defects.
3. HP does not warrant that the operation of HP products will be uninterrupted or error free. If HP is unable, within a reasonable time, to repair or replace any product to a condition as warranted, customer will be entitled to a refund of the purchase price upon prompt return of the product.
4. HP products may contain remanufactured parts equivalent to new in performance or may have been subject to incidental use.
5. The warranty period begins on the date of delivery or on the date of installation if installed by HP. If customer schedules or delays HP installation more than 30 days after delivery, warranty begins on the 31st day from delivery.
6. Warranty does not apply to defects resulting from (a) improper or inadequate maintenance or calibration, (b) software, interfacing, parts or supplies not supplied by HP, (c) unauthorized modification or misuse, (d) operation outside of the published environmental specifications for the product, or (e) improper site preparation or maintenance.
7. TO THE EXTENT ALLOWED BY LOCAL LAW, THE ABOVE WARRANTIES ARE EXCLUSIVE AND NO OTHER WARRANTY OR CONDITION, WHETHER WRITTEN OR ORAL IS EXPRESSED OR IMPLIED AND HP SPECIFICALLY DISCLAIMS ANY IMPLIED WARRANTIES OR CONDITIONS OR MERCHANTABILITY, SATISFACTORY QUALITY, AND FITNESS FOR A PARTICULAR PURPOSE.

8. HP will be liable for damage to tangible property per incident up to the greater of \$300,000 or the actual amount paid for the product that is the subject of the claim, and for damages for bodily injury or death, to the extent that all such damages are determined by a court of competent jurisdiction to have been directly caused by a defective HP product.
9. TO THE EXTENT ALLOWED BY LOCAL LAW, THE REMEDIES IN THIS WARRANTY STATEMENT ARE CUSTOMER'S SOLE AND EXCLUSIVE REMEDIES. EXCEPT AS INDICATED ABOVE, IN NO EVENT WILL HP OR ITS SUPPLIERS BE LIABLE FOR LOSS OF DATA OR FOR DIRECT, SPECIAL, INCIDENTAL, CONSEQUENTIAL (INCLUDING LOST PROFIT OR DATA), OR OTHER DAMAGE, WHETHER BASED IN CONTRACT, TORT, OR OTHERWISE.

FOR CONSUMER TRANSACTIONS IN AUSTRALIA AND NEW ZEALAND: THE WARRANTY TERMS CONTAINED IN THIS STATEMENT, EXCEPT TO THE EXTENT LAWFULLY PERMITTED, DO NOT EXCLUDE RESTRICT OR MODIFY AND ARE IN ADDITION TO THE MANDATORY STATUTORY RIGHTS APPLICABLE TO THE SALE OF THIS PRODUCT TO YOU.

## **ASSISTANCE**

### **Maintenance Agreements**

Product maintenance agreements and other customer assistance agreements are available for Hewlett-Packard products. For any assistance, contact your nearest Hewlett-Packard Sales and Service Office.

# Regional Sales Offices

**IMPORTANT**

## Regional Sales and Service Offices

<p>Eastern USA Sales Office Hewlett-Packard Company 2101 Gather Rd. Rockville, MD 20850 Tel: (301) 258-2000</p>	<p>Eastern USA Sales Office Hewlett-Packard Company 2101 Gather Rd. Rockville, MD 20850 Tel: (301) 258-2000</p>	<p>Midwestern USA Sales and Service Hewlett-Packard Company 5201 Tollview Drive Rolling Meadows, IL 60008 Tel: (708) 342-2000</p>
<p>Southern USA Sales and Service Hewlett-Packard Company 1995 North Park Place Atlanta, GA 30339 Sales Tel: (404) 955-1500 Fax: (404) 980-7292 Service Tel: (404) 850-2544 Fax: (404) 980-7292</p>	<p>Southern USA Service Center Hewlett-Packard Company 930 E. Campbell Road Richardson, TX 75081 Tel: (214) 699-4331</p>	<p>Western USA Service Center Hewlett-Packard Company 301 E. Evelyn Avenue Mountain View, CA 94041 Tel: (415) 694-2000 Fax: (415) 694-0601</p>
<p>Western USA Sales and Service Hewlett-Packard Company 24 Inverness Place East Englewood, CO 80112 Sales Tel: (303) 649-5000 Fax: (303) 649-5787 Service Tel: (303) 649-5512 Fax: (303) 649-5787</p>	<p>Western USA Sales and Service Hewlett-Packard Company 1421 South Manhattan Avenue Fullerton, CA 92631 Sales Tel: (714) 999-6700 Fax: (714) 778-3033 Service Tel: (714) 758-5490 Fax: (714) 778-3033</p>	<p>United States of America Customer Information Center Hewlett-Packard Company Tel: (800) 752-0900 6:00 am to 5:00 pm Pacific Time Parts Direct: 1-800-227-8164</p>
<p>South Eastern Europe Sales and Service Hewlett-Packard Ges. m.b.h. Liebigasse 1 P.O. Box 72 A-1222 Vienna, Austria Telephone: 43 222 2500 0 Telex: 13 4425</p>	<p>European Multicountry Region Sales and Service Hewlett-Packard S.A. P.O. Box 95 150, Route dv Nant_dl_AVRIL CH-1217 Meyrin 2 Geneva, Switzerland Telephone: (41/22) 780-8111 Fax: (41/22) 780-8542</p>	<p>Northern Europe Sales and Service Hewlett-Packard Nederland B.V. Startbaan 16 1187 XR Amstelveen, The Netherlands P.O. Box 667 Telephone: 31/20 5476911 X 6631 Fax: 31-20-6471825NL</p>

<p>Asia Sales and Service Hewlett-Packard Asia Ltd. 22-30/F Peregrine Tower Lippo Center 89 Queensway, Central Hong Kong G.P.O. Box 863 Hong Kong Telephone: 852-848-7777 Fax: 852-868-4997</p>	<p>Japan Sales and Service Yokogawa-Hewlett-Packard Ltd. 3-29-21, Takaido-Higashi Suginami-Ku, Tokyo 168 Telephone: 81 3 3331-6111 Fax: 81 3 3331-6631</p>	<p>International Sales Branch Headquarters Sales and Service Hewlett-Packard S.A. 39 Rue Veyrot P.O. Box 365 1217 Meyrin 1 Geneva, Switzerland Telephone: 41-22-780-4111 Fax: 41-22-780-4770</p>
<p>Australia, New Zealand Sales and Service Hewlett-Packard Ltd. P.O. Box 221 31-41 Joseph Street Blackburn, Victoria 3130 Telephone: (61/3) 895-2895 Fax: (61/3) 898-9257</p>	<p>Canada Sales and Service Hewlett-Packard (Canada) Ltd. 5150 Spectrum Way Mississauga, Ontario L4W 5G1 Canada Telephone: (416) 206-4725 Fax: (416) 206-4739</p>	<p>Canada Service Center Hewlett-Packard Company 17500 Transcanada Highway S. Serv Road Kirkland, Quebec H9J 2X8 Canada Telephone: (416) 206-3295</p>
<p>Canada Service Center Hewlett-Packard Ltd. 11120 178 Street Edmonton, Alberta T5S 1P2 Canada Telephone: (403) 486-6666 Fax: (403) 489-8764</p>	<p>Latin America Hewlett-Packard Company LAHQ Mexico City Col. Lomas de Virreyes 11000 Mexico D.F. Mexico Telephone: (52/5) 326-4000 Fax: (52/5) 202 7718</p>	<p>United Kingdom Sales and Service Hewlett-Packard Ltd. Cain Road Amen Corner Bracknell, Berkshire RG12 1HN United Kingdom Telephone: 44 344 360000</p>



---

# **1 Using HP-IB**

## Overview of the Test Set

The Test Set combines numerous separate test instruments and an Instrument BASIC (IBASIC) Controller into one package. All of the Test Set's functions can be automatically controlled through application programs running on the built-in IBASIC Controller or on an external controller connected through HP-IB.

Developing programs for the Test Set is simplified if the programmer has a basic understanding of how the Test Set operates. An overview of the Test Set's operation is best presented in terms of how information flows through the unit. The simplified block diagrams shown in [Figure 1-1 on page 24](#) and [Figure 1-2 on page 25](#) depict how instrument control information and measurement result information are routed among the Test Set's instruments, instrument control hardware, built-in IBASIC controller, and other components.

The Test Set has two operating modes: Manual Control mode and Automatic Control mode. In Manual Control mode the Test Set's operation is controlled through the front panel keypad/rotary knob. There are two Automatic Control modes: Internal and External. In Internal Automatic Control mode the Test Set's operation is controlled by an application program running on the built-in IBASIC Controller. In External Automatic Control mode the Test Set's operation is controlled by an external controller connected to the Test Set through the HP-IB interface.

## Manual Control Mode

The Test Set's primary instruments are shown on the left side of [Figure 1-1 on page 24](#). There are two classes of instruments in the Test Set: signal analyzers (RF Analyzer, AF Analyzer, Oscilloscope, Spectrum Analyzer) and signal sources (RF Generator, AF Generator #1, AF Generator #2).

Since so many instruments are integrated into the Test Set, it is not feasible to have an actual "front panel" for each instrument. Therefore, each instrument's front panel is maintained in firmware and is displayed on the display whenever the instrument is selected. Only one instrument front panel can be displayed at any given time (up to four measurement results can be displayed simultaneously if desired). Just as with stand alone instruments, instrument front panels in the Test Set can contain instrument setting information, measurement result(s), or data input from the DUT (Device Under Test).

Using the Test Set in Manual Control mode is analogous to using a set of bench or rack-mounted test equipment. To obtain a measurement result with a bench or racked system, the desired measurement must be "active." For example, if an RF power meter is in the bench or racked system and the user wishes to measure the power of an RF carrier they must turn the power meter on, and look at the front panel to see the measurement result. Other instruments in the system may be turned off but this would not prevent the operator from measuring the RF power.

Conceptually, the same is true for the Test Set. In order to make a measurement or input data from a DUT, the desired measurement field or data field must be "active." This is done by using the front panel keypad/rotary knob to select the instrument whose front panel contains the desired measurement or data field and making sure that the desired measurement or data field is turned ON.

[Figure 1-1 on page 24](#) shows that instrument selection is handled by the screen control hardware which routes the selected instrument's front panel to the display. Once an instrument's front panel is displayed on the display, the user can manipulate the instrument settings, such as turning a specific measurement or data field on or off, using the keypad/rotary knob. [Figure 1-1](#) also shows that instrument setup is handled by the Instrument Control hardware which routes setup information from the front panel to the individual instruments.

An HP-IB/RS-232/Parallel Printer interface is located in the Test Set. In Manual Control mode this provides the capability of connecting an external HP-IB, serial, or parallel printer to the Test Set so that display screens can be printed.

## Internal Automatic Control Mode

In Internal Automatic Control mode the Test Set's operation is controlled by an application program running on the built-in Instrument BASIC (IBASIC) Controller. The built-in controller runs programs written in IBASIC, a subset of the Hewlett-Packard BASIC programming language used on the HP 9000 Series 200/300 System Controllers. IBASIC is the only programming language supported on the built-in IBASIC Controller.

### **Similarities Between the Test Set's IBASIC Controller and Other Single-Tasking Controllers**

The architecture of the IBASIC Controller is similar to that of other single-tasking instrumentation controllers. Only one program can be run on the IBASIC Controller at any given time. The program is loaded into RAM from some type of mass storage device. Four types of mass storage devices are available to the Test Set: SRAM PC cards, ROM memory cards connected to the HP-IB interface, and internal ROM and RAM. Three types of interfaces are available for connecting to external instruments and equipment: HP-IB, RS-232, and 16-bit parallel.

[Figure 1-2 on page 25](#) shows how information is routed inside the Test Set when it is in Internal Automatic Control mode. In Manual Control mode certain Test Set resources are dedicated to manual operation. These resources are switched to the IBASIC Controller when an IBASIC program is running. These include the serial interface ports at select codes 9, 10, and 11, the HP-IB interface at select code 7, the parallel printer interface ports at select codes 15 and 16, and the display. In Manual Control mode, front panel information (instrument settings, measurement results, data input from the DUT) is routed to the display through the screen control hardware. In Internal Automatic Control mode the measurement results and data input from the DUT are routed to the IBASIC Controller through a dedicated HP-IB interface. Also, in Internal Automatic Control mode, the display is dedicated to the IBASIC Controller for program and graphics display. This means instrument front panels cannot be displayed on the display when an IBASIC program is running.

## **Differences Between the Test Set's IBASIC Controller and Other Single-Tasking Controllers**

The IBASIC Controller is unlike other single tasking instrumentation controllers in several ways. First, it does not have a keyboard. This imposes some limitations on creating and editing IBASIC programs directly on the Test Set. In Internal Automatic Control mode a “virtual” keyboard is available in firmware which allows the operator to enter alphanumeric data into a dedicated input field using the rotary knob. This is not the recommended programming mode for the IBASIC Controller. This feature is provided to allow user access to IBASIC programs for short edits or troubleshooting. Several programming modes for developing IBASIC programs to run on the internal IBASIC Controller are discussed in this manual.

Secondly, the IBASIC Controller has a dedicated HP-IB interface, select code 8 in [Figure 1-2 on page 25](#), for communicating with the internal instruments of the Test Set. This HP-IB interface is only available to the IBASIC Controller. There is no external connector for this HP-IB interface. No external instruments may be added to this HP-IB interface. The HP-IB interface, select code 7 in [Figure 1-2](#), is used to interface the Test Set to external instruments or to an external controller. The dedicated HP-IB interface at select code 8 conforms to the IEEE 488.2 Standard in all respects but one. The difference being that each instrument on the bus does not have a unique address. The Instrument Control Hardware determines which instrument is being addressed through the command syntax. Refer to the *HP-IB Syntax Reference Guide* for a listing of the HP-IB command syntax for the Test Set.

## External Automatic Control Mode

In External Automatic Control mode the Test Set's operation is controlled by an external controller connected to the Test Set through the HP-IB interface. When in External Automatic Control mode the Test Set's internal configuration is the same as in Manual Control Mode with two exceptions:

1. Configuration and setup commands are received through the external HP-IB interface, select code 7, rather than from the front-panel keypad/rotary knob.
2. The MEASure command is used to obtain measurement results and DUT data through the external HP-IB interface.

[Figure 1-1 on page 24](#) shows how information is routed inside the Test Set in Manual Control mode. [Figure 1-1](#) also shows that certain Test Set resources are dedicated to the IBASIC Controller (PC Card, internal ROM, Serial Ports 10 and 11) and are not directly accessible to the user in Manual Control Mode. In addition, [Figure 1-1](#) shows that Serial Port 9 and Parallel Printer Port 15 are accessible as write-only interfaces for printing in Manual Control mode. These same conditions are true when in External Automatic Control mode. If the user wished to access these resources from an external controller, an IBASIC program would have to be run on the Test Set from the external controller.

## Writing programs for the Test Set

One of the design goals for automatic control of the Test Set was that it operate the same way programmatically as it does manually. This is a key point to remember when developing programs for the Test Set. The benefit of this approach is that to automate a particular task, one need only figure out how to do the task manually and then duplicate the same process in software. This has several implications when designing and writing programs for the Test Set:

1. In Manual Control mode a measurement must be “active” in order to obtain a measurement result or input data from the DUT. From a programming perspective this means that before attempting to read a measurement result or to input data from the DUT, the desired screen for the measurement result or data field must be selected using the DISPlay command and the field must be in the ON state.
2. In Manual Control mode instrument configuration information is not routed through the screen control hardware. From a programming perspective this means that configuration information can be sent to any desired instrument without having to first select the instrument’s front panel with the DISPlay command.

Keeping these points in mind during program development will minimize program development time and reduce problems encountered when running the program.

**Figure 1-1** Manual Control Mode

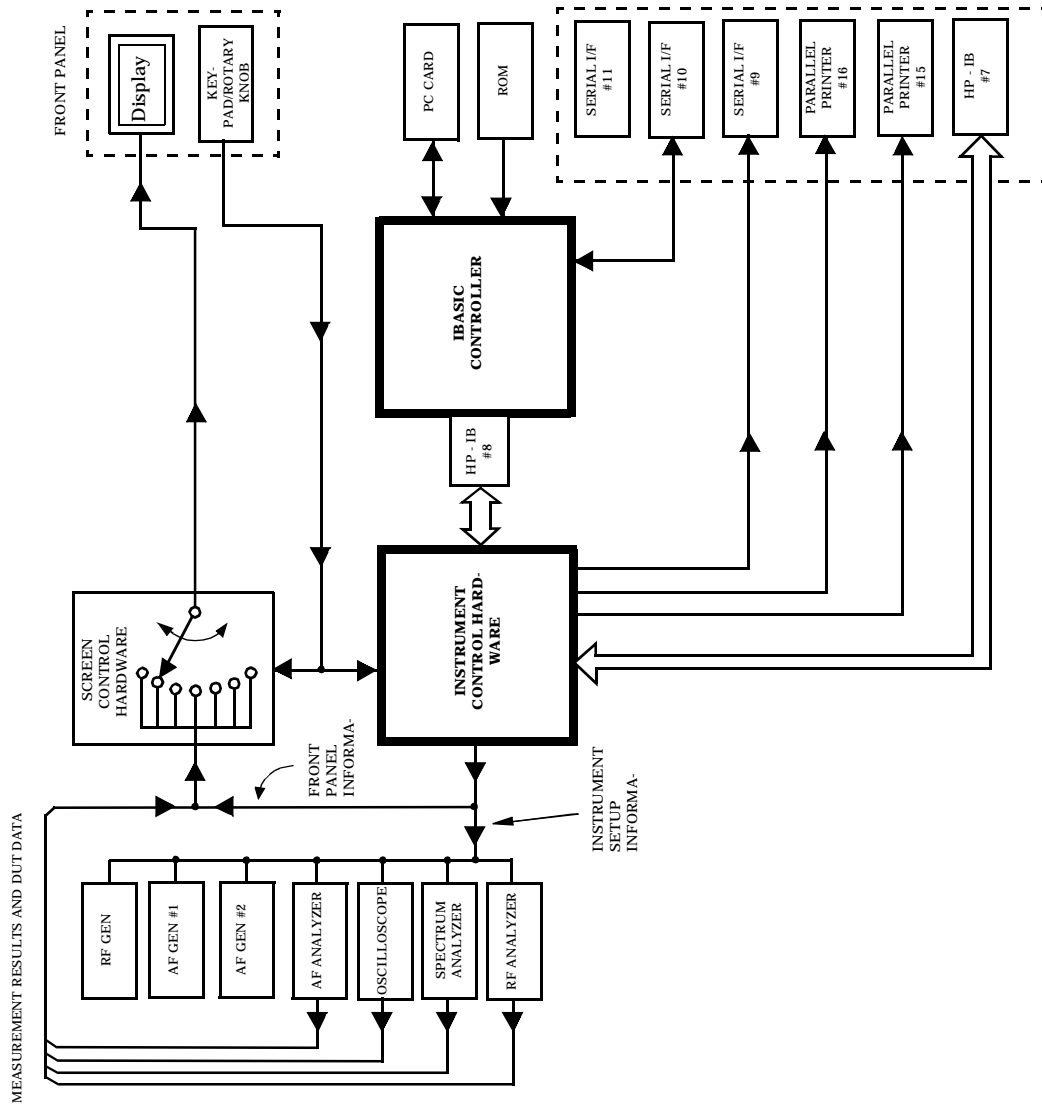



**Figure 1-2 Internal Automatic Control Mode**

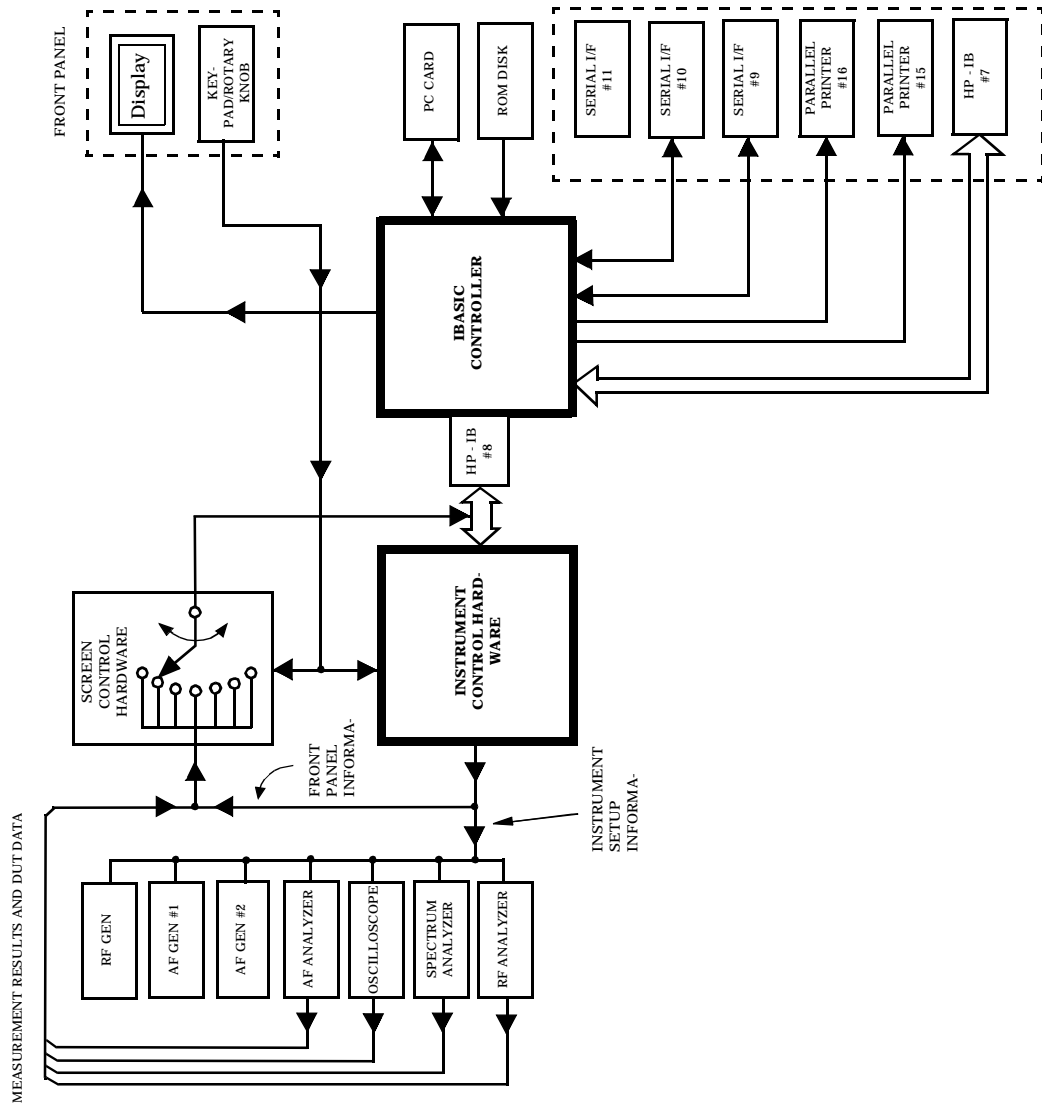

## Getting Started

### What is HP-IB?

The Hewlett-Packard Interface Bus (HP-IB) is Hewlett-Packard's implementation of the IEEE 488.1-1987 Standard Digital Interface for Programmable Instrumentation. Incorporation of the HP-IB into the Test Set provides several valuable capabilities:

- Programs running in the Test Set's IBASIC Controller can control all the Test Set's functions using its internal HP-IB. This capability provides a single-instrument automated test system.
- Programs running in the Test Set's IBASIC Controller can control other instruments connected to the external HP-IB.
- An external controller, connected to the external HP-IB, can remotely control the Test Set.
- An HP-IB printer, connected to the external HP-IB, can be used to print test results and full screen images.

## HP-IB Information Provided in This Manual

### What Is Explained

- How to configure the Test Set for HP-IB operation
- How to make an instrument setting over HP-IB
- How to read-back instrument settings over HP-IB
- How to make measurements over HP-IB
- How to connect external PCs, terminals or controllers to the Test Set
- HP-IB command syntax for the Test Set
- IBASIC program development
- IBASIC program transfer over HP-IB
- Various advanced functions such as, increasing measurement throughput, status reporting, error reporting, pass control, and so forth

### What Is Not Explained

- HP-IB (IEEE 488.1, 488.2) theory of operation<sup>1</sup>
- HP-IB electrical specifications<sup>1</sup>
- HP-IB connector pin functions<sup>1</sup>
- IBASIC programming (other than general guidelines related to HP-IB)<sup>2</sup>

---

1. Refer to the *Tutorial Description of the Hewlett-Packard Interface Bus* (HP P/N 5952-0156) for detailed information on HP-IB theory and operation.  
2. Refer to the *HP Instrument BASIC Users Handbook* (HP P/N E2083-90005) for more information on the IBASIC Version 2.0 language.

## General HP-IB Programming Guidelines

The following guidelines should be considered when developing programs which control the Test Set through HP-IB:

- Guideline #1.
  1. Bring the Test Set to its preset state using the front-panel PRESET key. This initial step allows you to start developing the measurement sequence with most fields in a known state.
  2. Make the measurement manually using the front-panel controls of the Test Set. Record, in sequential order, the screens selected and the settings made within each screen. The record of the screens selected and settings made in each screen becomes the measurement procedure.
  3. Record the measurement result(s).
  4. Develop the program using the measurement procedure generated in [step 2](#). Be sure to start the programmatic measurement sequence by bringing the Test Set to its preset state using the \*RST Common Command. As the measurement procedure requires changing screens, use the DISPlay command to select the desired screen followed by the correct commands to set the desired field(s).

---

NOTE

When IBASIC programs are running the display is dedicated to the IBASIC Controller for program and graphics display. This means instrument front panels are not displayed when an IBASIC program is running. However, the DISPlay <screen> command causes all setting and measurement fields in the <screen> to be accessible programmatically. Attempting to read from a screen that has not been made accessible by the DISPlay command will cause  
HP-IB Error:-420 Query UNTERMINATED, or  
HP-IB Error: -113 Undefined header

Make sure the desired measurement is in the ON state. This is the preset state for most measurements. However, if a previous program has set the state to OFF, the measurement will not be available. Attempting to read from a measurement field that is not in the ON state will cause HP-IB Error:-420 Query UNTERMINATED.

5. If the trigger mode has been changed, trigger a reading.

---

NOTE

Triggering is set to FULL SETTling and REPetitive RETRiggering after receipt of the \*RST Common Command. These settings cause the Test Set to trigger itself and a separate trigger command is not necessary.

- Send the MEASure query command to initiate a reading. This will place the measured value into the Test Set's Output Queue.

**NOTE**

When making AF Analyzer SINAD, Distortion, Signal to Noise Ratio, AF Frequency, DC Level, or Current measurements, the measurement type must first be selected using the SElect command. For example, MEAS:AFR:SEL'SINAD' followed by MEAS:AFR:SINAD?

- Use the ENTER statement to transfer the measured value to a variable within the context of the program.

The following example program illustrates how to make settings and then take a reading from the Test Set. This setup takes a reading from the spectrum analyzer marker after tuning it to the RF generator's output frequency.

**Example**

```

10 Addr=714
20 OUTPUT Addr;"*RST" !Preset to known state
30 OUTPUT Addr;"TRIG:MODE:RETR SING" !Sets single trigger
40 OUTPUT Addr;"DISP RFG" !Selects the RF Gen screen
50 OUTPUT Addr;"AFGL:FM:STAT OFF" !Turns FM OFF
60 OUTPUT Addr;"RFG:AMPL -66 DBM" !Sets RF Gen ampl to -66 dBm
70 OUTPUT Addr;"RFG:FREQ 500 MHZ" !Sets RF Gen freq to 500 MHz
80 OUTPUT Addr;"RFG:AMPL:STAT ON" !Turns RF Gen output ON
90 OUTPUT Addr;"DISP SAN" !Selects Spectrum Analyzer's screen
100 OUTPUT Addr;"SAN:CRF 500 MHZ" !Center Frequency 500 MHz
110 ! -----MEASUREMENT SEQUENCE-----
120 OUTPUT Addr;"TRIG" !Triggers reading
130 OUTPUT Addr;"MEAS:SAN:MARK:LEV?" !Query of Spectrum
140 !Analyzer's marker level
150 ENTER Addr;Lvl !Places measured value in variable Lvl
160 DISP Lvl!Displays value of Lvl
170 END

```

The RF Generator's output port and the Spectrum Analyzer's input port are preset to the RF IN/OUT port. This allows the Spectrum Analyzer to measure the RF Generator with no external connections. The Spectrum Analyzer marker is always tuned to the center frequency of the Spectrum Analyzer after preset. With the RF Generator's output port and Spectrum Analyzer input port both directed to the RF IN/OUT port, the two will internally couple with 46 dB of gain, giving a measured value of approximately -20 dBm. While not a normal mode of operation this setup is convenient for demonstration since no external cables are required. This also illustrates the value of starting from the preset state since fewer programming commands are required.

- **Guideline #2.**

If the program stops or “hangs up” when trying to ENTER a measured value, it is most likely that the desired measurement field is not available. There are several reasons that can happen:

1. The screen where the measurement field is located has not been DISPLAYed before querying the measurement field.
2. The measurement is not turned ON.
3. The squelch control is set too high. If a measurement is turned ON but is not available due to the Squelch setting, the measurement field contains four dashes (- - - -). This is a valid state. The Test Set is waiting for a signal of sufficient strength to unsquelch the receiver before making a measurement. If a measurement field which is squelched is queried the Test Set will wait indefinitely for the receiver to unsquelch and return a measured value.
4. The RF Analyzer's Input Port is set to ANT (antenna) while trying to read TX power. TX power is not measurable with the Input Port set to ANT. The TX power measurement field will display four dashes (- - - -) indicating the measurement is unavailable.
5. The input signal to the Test Set is very unstable causing the Test Set to continuously autorange. This condition will be apparent if an attempt is made to make the measurement manually.
6. Trigger mode has been set to single trigger (TRIG:MODE:RETRig SINGLE) and a new measurement cycle has not been triggered before attempting to read the measured value.
7. The program is attempting to make an FM deviation or AM depth measurement while in the RX TEST screen. FM or AM measurements are not available in the RX TEST screen. FM or AM measurements are made from the AF Analyzer screen by setting the AF Anl In field to FM or AM Demod.

- **Guideline #3.**

The syntax diagrams in the *HP-IB Syntax Reference Guide* show where single quotes are needed and where spaces are needed.

**Example**

```
OUTPUT 714;"DISP<space>AFAN"
```

```
OUTPUT 714;"AFAN:DEMP<space>'Off' "
```

**Improper use of single quotes and spaces will cause,  
HP-IB Error:-103 Invalid Separator**

- **Guideline #4.**

When making settings to fields that can be turned OFF with the STATE ON/OFF command (refer to the *HP-IB Syntax Reference Guide*), make sure the STATE is ON if the program uses that field. Note that if the STATE is OFF, just setting a numeric value in the field will not change the STATE to ON. This is different than front-panel operation whereby the process of selecting the field and entering a value automatically sets the STATE to ON. Programmatically, fields must be explicitly set to the ON state if they are in the OFF state.

For example, the following command line would set a new AMPS ENCoder SAT tone deviation and then turn on the SAT tone (note the use of the; to back up one level in the command hierarchy so that more than one command can be executed in a single line):

**Example**

```
OUTPUT 714;"ENC:AMPS:SAT:FM 2.1 KHZ;FM:STAT ON"
```

To just turn on the SAT tone without changing the current setting the following commands would be used:

**Example**

```
OUTPUT 714;"ENC:AMPS:SAT:FM:STAT ON"
```



## Control Annunciators

The letters and symbols at the top right corner of the display indicate these conditions:

- R indicates the Test Set is in remote mode. The Test Set can be put into the remote mode by an external controller or by an IBASIC program running on the built-in IBASIC controller.
- L indicates that the Test Set has been addressed to Listen.
- T indicates that the Test Set has been addressed to Talk.
- S indicates that the Test Set has sent the Require Service message by setting the Service Request (SRQ) bus line true. (See [“Status Reporting” on page 122.](#))
- C indicates that the Test Set is currently the Active Controller on the bus.
- \* indicates that an IBASIC program is running.
- ? indicates that an IBASIC program is waiting for a user response.
- - indicates that an IBASIC program is paused.

## Preparing the Test Set For HP-IB Use

1. If other HP-IB devices are in the system, attach an HP-IB cable from the Test Set's HP-IB connector to any one of the other devices in the test system.
2. Access the I/O CONFIGURE screen and perform the following steps:
  - a. Set the Test Set's HP-IB address using the `HP-IB Adrs` field.
  - b. Set the Test Set's HP-IB Controller capability using the `Mode` field.
    - `Talk&Listen` configures the Test Set to *not* be the System Controller. The Test Set has Active Controller capability (take control/pass control) in this mode. Use this setting if the Test Set will be controlled through HP-IB from an external controller.
    - `Control` configures the Test Set to be the System Controller. Use this setting if the Test Set will be the only controller on the HP-IB. Selecting the Control mode automatically makes the Test Set the Active Controller.

---

**NOTE**

---

Only one System Controller can be configured in an HP-IB system. Refer to [“Passing Control” on page 187](#) for further information.

3. If an HP-IB printer is or will be connected to the Test Set's HP-IB connector then,
  - a. access the PRINT CONFIGURE screen.
  - b. select one of the supported HP-IB printer models using the `Model` field.
  - c. set the `Printer Port` field to HP-IB.
  - d. set the printer address using the `Printer Address` field.

## Using the HP-IB with the Test Set's built-in IBASIC Controller

The Test Set has two HP-IB interfaces, an internal-only HP-IB at select code 8 and an external HP-IB at select code 7. The HP-IB at select code 8 is only available to the built-in IBASIC Controller and is used exclusively for communication between the IBASIC Controller and the Test Set. The HP-IB at select code 7 serves three purposes:

1. It allows the Test Set to be controlled by an external controller
2. It allows the Test Set to print to an external HP-IB printer
3. It allows the built-in IBASIC Controller to control external HP-IB devices

IBASIC programs running on the Test Set's IBASIC Controller must use the internal-only HP-IB at select code 8 to control the Test Set. IBASIC programs would use the external HP-IB at select code 7 to control HP-IB devices connected to the HP-IB connector.

---

**NOTE**

---

Refer to [“Overview of the Test Set” on page 18](#) for a detailed explanation of the Test Set's architecture.

When using a BASIC language Workstation with an HP-IB interface at select code 7 to control the Test Set, HP-IB commands would look like this:

**Example**

```
! This command is sent to the Test Set at address 14.  
OUTPUT 714;"*RST"  
  
! This command is sent to another instrument whose address is 19.  
OUTPUT 719;"*RST"
```

When executing the same commands on the Test Set's IBASIC Controller, the commands would look like this:

**Example**

```
OUTPUT 814;"*RST"  
  
! Command sent to internal-only HP-IB at select code 8,  
! Test Set's address does not change  
OUTPUT 719;"*RST"  
  
! Command sent to external HP-IB at select code 7,  
! other instrument's address does not change.
```

## Basic Programming Examples

The following simple examples illustrate the basic approach to controlling the Test Set through the HP-IB. The punctuation and command syntax used for these examples is given in the *HP-IB Syntax Reference Guide*.

The bus address 714 used in the following BASIC language examples assumes an HP-IB interface at select code 7, and a Test Set HP-IB address of 14. All examples assume an external controller is being used.

### To Change a Field's Setting over HP-IB

1. Use the DISPLAY command to access the screen containing the field whose setting is to be changed.
2. Make the desired setting using the proper command syntax (refer to the *HP-IB Syntax Reference Guide* for proper syntax).

The following example makes several instrument setting changes:

#### Example

```
OUTPUT 714;"DISP RFG" !Display the RF Generator screen.  
OUTPUT 714;"RFG:FREQ 850 MHZ" !Set the RF Gen Freq to 850 MHz.  
OUTPUT 714;"RFG:OUTP 'DUPL'!"!Set the Output Port to Duplex.  
OUTPUT 714;"DISP AFAN"!Display the AF Analyzer screen.  
OUTPUT 714;"AFAN:INP 'FM DEMOD'!"!Set the AF Anl In to FM Demod.
```

## To Read a Field's Setting over HP-IB

1. Use the DISPlay command to access the screen containing the field whose setting is to be read.
2. Use the Query form of the syntax for that field to place the setting value into the Test Set's output buffer.
3. Enter the value into the correct variable type within the program context (refer to the *HP-IB Syntax Reference Guide*, for proper variable type).

The following example reads several fields.

### Example

```
OUTPUT 714;"DISP AFAN"!Display the AF Analyzer screen.
OUTPUT 714;"AFAN:INP?"!Query the AF Anl In field
ENTER 714;Af_input$ !Enter returned value into a string ariable.
OUTPUT 714;"DISP RFG"!Display the RF Generator screen
OUTPUT 714;"RFG:FREQ?"!Query the RF Gen Frequency field.
ENTER 714;Freq !Enter the returned value into a numeric variable
```

---

#### NOTE

When querying measurements or settings through HP-IB, the Test Set always returns numeric values in HP-IB Units or Attribute Units, regardless of the current Display Units setting. Refer to “[HP-IB Units \(UNITs\)](#)” on page 73 and “[Attribute Units \(AUNits\)](#)” on page 76 for further information.

---

## To Make a Simple Measurement

The basic method for making a measurement is very similar to the method used to read a field setting.

1. Use the DISPlay command to access the screen containing the desired measurement.
2. Use the MEASure form of the syntax for that measurement to place the measured value into the Test Set's output buffer.
3. Enter the value into the correct variable type within the program context (refer to the *HP-IB Syntax Reference Guide* for proper variable type).

The following example measures the power of an RF signal.

### Example

```
!Display the RF Analyzer screen.  
OUTPUT 714;"DISP RFAN"  
  
!Measure the RF power and place result in output buffer.  
OUTPUT 714;"MEAS:RFR:POW?"  
  
!Enter the measured value into a numeric variable.  
ENTER 714;Tx_power
```

The above example is very simple and is designed to demonstrate the fundamental procedure for obtaining a measurement result. Many other factors must be considered when designing a measurement procedure, such as instrument settings, signal routing, settling time, filtering, triggering and measurement speed.

---

## Remote Operation

The Test Set can be operated remotely through the Hewlett-Packard Interface Bus (HP-IB). Except as otherwise noted, the Test Set complies with the IEEE

488.1-1987 and IEEE 488.2-1987 Standards. Bus compatibility, programming and data formats are described in the following sections.

All front-panel functions, except those listed in [Table 1-1](#), are programmable through HP-IB.

**Table 1-1 Non-Programmable Front Panel Functions**

Function	Comment
ON/OFF Power Switch	
Volume Control Knob	
Squelch Control Knob	The position of the squelch control knob cannot be programmed. However squelch can be programmed to either the Open or Fixed position. Refer to the Test Set's <i>HP-IB Syntax Reference Guide</i> for more information.
Cursor Control Knob	
SHIFT Key	
CANCEL Key	
YES Key	
NO Key	
ENTER Key	
Backspace (left-arrow) Key	
PREV Key	
HOLD (SHIFT, PREV Keys)	
PRINT (SHIFT, TESTS Keys)	
ADRS (SHIFT, LOCAL Keys)	
ASSIGN (SHIFT, k4 Keys)	
RELEASE (SHIFT, k5 Keys)	

## Remote Capabilities

### Conformance to the IEEE 488.1-1987 Standard

For all IEEE 488.1 functions implemented, the Test Set adheres to the rules and procedures as outlined in that Standard.

### Conformance to the IEEE 488.2-1987 Standard

For all IEEE 488.2 functions implemented, the Test Set adheres to the rules and procedures as outlined in that Standard with the exception of the \*OPC Common Command. Refer to the \*OPC Common Command description.

### IEEE 488.1 Interface Functions

The interface functions that the Test Set implements are listed in [Table 1-2](#).

**Table 1-2 Test Set IEEE 488.1 Interface Function Capabilities**

Function	Capability
Talker	T6: No Talk Only Mode
Extended Talker	T0: No Extended Talker Capability
Listener	L4: No Listen Only Mode
Extended Listener	LE0: No Extended Listener Capability
Source Handshake	SH1: Complete Capability
Acceptor Handshake	AH1: Complete Capability
Remote/Local	RL1: Complete Capability
Service Request	SR1: Complete Capability
Parallel Poll	PP0: No Parallel Poll Capability
Device Clear	DC1: Complete Capability
Device Trigger	DT1: Complete Capability
Controller	C1: System Controller C3: Send REN C4: Respond to SRQ C11: No Pass Control to Self, No Parallel Poll
Drivers	E2: Tri-State Drivers



---

## Addressing

### Factory Set Address

The Test Set's HP-IB address is set to decimal 14 at the factory. The address can be changed by following the instructions in [“Setting the Test Set's Bus Address” on page 41](#).

### Extended Addressing

Extended addressing (secondary command) capability is not implemented in the Test Set.

### Multiple Addressing

Multiple addressing capability is not implemented in the Test Set.

### Setting the Test Set's Bus Address

The Test Set's HP-IB bus address is set using the `HP-IB Adrs` field which is located on the I/O CONFIGURE screen. To set the HP-IB bus address; select the I/O CONFIGURE screen and position the cursor next to the `HP-IB Adrs` field. The address can be set from decimal 0 to 30 using the numeric DATA keys, or by pushing and then rotating the Cursor Control knob. There are no DIP switches for setting the HP-IB bus address in the Test Set. The new setting is retained when the Test Set is turned off.

### Displaying the Bus Address

The Test Set's HP-IB bus address can be displayed by pressing and releasing the SHIFT key, then the LOCAL key. The address is displayed in the upper left-hand corner of the display screen.

## **IEEE 488.1 Remote Interface Message Capabilities**

The remote interface message capabilities of the Test Set and the associated IEEE 488.1 messages and control lines are listed in [Table 1](#).

**Table 1                      Test Set IEEE 488.1 Interface Message Capability**

<b>Message Type</b>	<b>Implemented</b>	<b>Response</b>	<b>IEEE 488.1 Message</b>
Data	Yes	All front-panel functions, except those listed in <a href="#">Table 1-2 on page 40</a> , are programmable. The Test Set can send status byte, message and setting information. All measurement results (except dashed “- - - -” displays) and error messages are available through the bus.	DAB END MTA MLA OTA
Remote	Yes	Remote programming mode is entered when the Remote Enable (REN) bus control line is true and the Test Set is addressed to listen. The R annunciator will appear in the upper-right corner of the display screen when the Test Set is in remote mode. All front-panel keys are disabled (except for the LOCAL key, POWER switch, Volume control and Squelch control knobs). When the Test Set enters remote mode the output signals and internal settings remain unchanged, except that triggering is reset to the state it was last set to in remote mode (Refer to <a href="#">“Triggering Measurements” on page 103</a> ).	REN MLA

<b>Message Type</b>	<b>Implemented</b>	<b>Response</b>	<b>IEEE 488.1 Message</b>
Local	Yes	The Test Set returns to local mode (full front-panel control) when either the Go To Local (GTL) bus command is received, the front-panel LOCAL key is pressed or the REN line goes false. When the Test Set returns to local mode the output signals and internal settings remain unchanged, except that triggering is reset to TRIG:MODE:SETT FULL;RETR REP. The LOCAL key will not function if the Test Set is in the local lockout mode.	GTL MLA
Local Lockout	Yes	Local Lockout disables all front-panel keys including the LOCAL key. Only the System Controller or the POWER switch can return the Test Set to local mode (front-panel control).	LLO
Clear Lockout/ Set Local	Yes	The Test Set returns to local mode (front-panel control) and local lockout is cleared when the REN bus control line goes false. When the Test Set returns to local mode the output signals and internal settings remain unchanged, except that triggering is set to TRIG:MODE:SETT FULL;RETR REP.	REN

<b>Message Type</b>	<b>Implemented</b>	<b>Response</b>	<b>IEEE 488.1 Message</b>
Service Request	Yes	The Test Set sets the Service Request (SRQ) bus line true if any of the enabled conditions in the Status Byte Register, as defined by the Service Request Enable Register, are true.	SRQ
Status Byte	Yes	The Test Set responds to a Serial Poll Enable (SPE) bus command by sending an 8-bit status byte when addressed to talk. Bit 6 will be true, logic 1, if the Test Set has sent the SRQ message	SPE SPD STB MTA
Status Bit	No	The Test Set does not have the capability to respond to a Parallel Poll.	PPE PPD PPU PPC IDY

Message Type	Implemented	Response	IEEE 488.1 Message
Clear	Yes	<p>This message clears the Input Buffer and Output Queue, clears any commands in process, puts the Test Set into the Operation Complete idle state and prepares the Test Set to receive new commands. The Device Clear (DCL) or Selected Device Clear (SDC) bus commands</p> <ul style="list-style-type: none"> <li>• do not change any settings or stored data (except as noted previously)</li> <li>• do not interrupt front panel I/O or any Test Set operation in progress (except as noted previously)</li> <li>• do not change the contents of the Status Byte Register (other than clearing the MAV bit as a consequence of clearing the Output Queue).</li> </ul> <p>The Test Set responds equally to DCL or SDC bus commands.</p>	DCL SDC MLA

<b>Message Type</b>	<b>Implemented</b>	<b>Response</b>	<b>IEEE 488.1 Message</b>
Trigger	Yes	If in remote programming mode and addressed to listen, the Test Set makes a triggered measurement following the trigger conditions currently in effect in the instrument. The Test Set responds equally to the Group Execute Trigger (GET) bus command or the *TRG Common Command.	GET MLA
Take Control	Yes	The Test Set begins to act as the Active Controller on the bus.	TCT MTA
Abort	Yes	The Test Set stops talking and listening	IFC

## Remote/Local Modes

### Remote Mode

In Remote mode all front-panel keys are disabled (except for the LOCAL key, POWER switch, Volume control and Squelch control). The LOCAL key is only disabled by the Local Lockout bus command. When in Remote mode and addressed to Listen the Test Set responds to the Data, Remote, Local, Clear (SDC), and Trigger messages. When the Test Set is in Remote mode, the **R** annunciator will be displayed in the upper right corner of the display screen and triggering is set to the state it was last set to in Remote mode (if no previous setting, the default is FULL SETTling and REPetitive RETRiggering). When the Test Set is being addressed to Listen or Talk the **L** or **T** annunciators will be displayed in the upper-right corner of the display screen.

### Local Mode

In Local mode the Test Set's front-panel controls are fully operational. The Test Set uses FULL SETTling and REPetitive RETRiggering in Local mode. When the Test Set is being addressed to Listen or Talk the **L** or **T** annunciators will be displayed in the upper-right corner of the display screen.

### Remote or Local Mode

When addressed to Talk in Remote or Local mode, the Test Set can issue the Data and Status Byte messages and respond to the Take Control message. In addition the Test Set can issue the Service Request Message (SRQ). Regardless of whether it is addressed to talk or listen, the Test Set will respond to the Clear (DCL), Local Lockout, Clear Lockout/Set Local, and Abort messages.



## Local To Remote Transitions

The Test Set switches from Local to Remote mode upon receipt of the Remote message (REN bus line true and Test Set is addressed to listen). No instrument settings are changed by the transition from Local to Remote mode, but triggering is set to the state it was last set to in Remote mode (if no previous setting, the default is FULL SETTling and REPetitive RETRiggering). The R annunciator in the upper-right corner of the display is turned on.

When the Test Set makes a transition from local to remote mode, all currently active measurements are flagged as invalid causing any currently available measurement results to become unavailable. If the HP-IB trigger mode is :RETR REP then a new measurement cycle is started and measurement results will be available for all active measurements when valid results have been obtained. If the HP-IB trigger mode is :RETR SING then a measurement cycle must be started by issuing a trigger event. Refer to [“Triggering Measurements” on page 103](#) for more information.

## Remote To Local Transitions

The Test Set switches from Remote to Local mode upon receipt of the Local message (Go To Local bus message is sent and Test Set is addressed to listen) or receipt of the Clear Lockout/Set Local message (REN bus line false). No instrument settings are changed by the transition from Remote to Local mode, but triggering is reset to FULL SETTling and REPetitive RETRiggering. The R annunciator in the upper right corner of the display is turned off.

If it is not in Local Lockout mode the Test Set switches from Remote to Local mode whenever the front-panel LOCAL key is pressed.

If the Test Set was in Local Lockout mode when the Local message was received, front-panel control is returned, but Local Lockout mode is not cleared. Unless the Test Set receives the Clear Lockout/Set Local message, the Test Set will still be in Local Lockout mode the next time it goes to the Remote mode.

## Local Lockout

The Local Lockout mode disables the front-panel LOCAL key and allows return to Local mode only by commands from the System Controller (Clear Lockout/Set Local message).

When a data transmission to the Test Set is interrupted, which can happen if the LOCAL key is pressed, the data being transmitted may be lost. This can leave the Test Set in an unknown state. The Local Lockout mode prevents loss of data or system control due to someone unintentionally pressing front-panel keys.

---

### NOTE

Return to Local mode can also be accomplished by setting the POWER switch to OFF and back to ON. However, returning to Local mode in this way has the following disadvantages:

1. It defeats the purpose of the Local Lockout mode in that the Active Controller will lose control of the test set.
  2. Instrument configuration is reset to the power up condition thereby losing the instrument configuration set by the Active Controller.
- 

## Clear Lockout/Set Local

The Test Set returns to Local mode when it receives the Clear Lockout/Set Local message. No instrument settings are changed by the transition from Remote mode with Local Lockout to Local mode but triggering is reset to FULL SETTling and REPetitive RETRiggering.



## Background

One of the most common remote user interface operations performed on an Test Set is to query and read a measurement result. Generally, this operation is accomplished by sending the query command to the Test Set, followed immediately by a request to read the requested measurement result. Using Hewlett-Packard Rocky Mountain BASIC (RMB) language, this operation would be written using the OUTPUT and ENTER command as follows:

### Query Example

```
OUTPUT 714;"MEAS:RFR:POW?"
```

```
ENTER 714;Power
```

Using this programming structure, the control program will stay on the ENTER statement until it is satisfied - that is - until the Test Set has returned the requested measurement result. This structure works correctly as long as the Test Set returns a valid measurement result. If, for some reason, the Test Set does not return a measurement result, the control program becomes “hung” on the ENTER statement and program execution effectively stops.

In order to prevent the control program from becoming “hung” programmers usually enclose the operation with some form of timeout function. The form of the timeout will of course depend upon the programming language being used. The purpose of the timeout is to specify a fixed amount of time that the control program will wait for the Test Set to return the requested result. After this time has expired the control program will abandon the ENTER statement and try to take some corrective action to regain control of the Test Set.

If the control program does not send the proper commands in the proper sequence when trying to regain control of the Test Set, unexpected operation will result. When this condition is encountered, power must be cycled on the Test Set to regain control.

This situation can be avoided entirely by:

1. sending a Selected Device Clear (SDC) interface message to put the Test Set’s HP-IB subsystem into a known state.
2. sending a command to terminate the requested measurement cycle.

These commands issued in this order will allow the control program to regain control of the Test Set. Any other sequence of commands will result in unexpected operation.

The following programs demonstrate a recommended technique for querying and entering data from the Test Set. This technique will prevent the Test Set from getting into a 'hung' state such that power must be cycled on the Test Set to regain manual or programmatic control.

There are a variety of programming constructs which can be used to implement this technique. In the programming examples presented, a function call is implemented which returns a numeric measurement result. The function call has two pass parameters; the query command (passed as a quoted string) and a time-out value (passed as a integer number).

The time-out value represents how long you want to wait, in seconds, for the Test Set to return a valid measurement result. If a valid measurement result is not returned by the Test Set within the time-out value, the function returns a very large number. The calling program can check the value and take appropriate action.

The program examples are written so as to be self-explanatory. In practice, the length of: variable names, line labels, function names, etc., will be implementation dependent.

## HP BASIC 'ON TIMEOUT' Example Program

The following example program demonstrates a recommended technique which can be utilized in situations where a measurement result timeout value of 32.767 seconds or less is adequate. In the HP RMB language, the timeout parameter for the ON TIMEOUT command has a maximum value of 32.767 seconds. If a timeout value of greater than 32.767 seconds is required refer to the ["HP BASIC 'MAV' Example Program"](#) on page 58.

The measurement result timeout value is defined to mean the amount of time the control program is willing to wait for the Test Set to return a valid measurement result to the control program.

Lines 10 thru 230 in this example set up a measurement situation to demonstrate the use of the recommended technique. The recommended technique is exemplified in the Measure Function.

---

### NOTE

Lines 50 and 60 should be included in the beginning of all control programs. These lines are required to ensure that the Test Set is properly reset. This covers the case where the program was previously run and was stopped with the Test Set in an error condition.

---

## Timeout Example

```

10 COM /Io_names/ INTEGER Inst_addr,Bus_addr
20 CLEAR SCREEN
30 Inst_addr=714
40 Bus_addr=7
50 CLEAR Inst_addr
60 OUTPUT Inst_addr;"TRIG:ABORT"
70 OUTPUT Inst_addr;"*RST"
80 OUTPUT Inst_addr;"DISP RFAN"
90 !
100 ! Execute a call to the Measure function with a request to measure RF
110 ! power. The time out value is specified as 10 seconds. The value
120 ! returned by the function is assigned to the variable Measure_result.
130 !
140 Measure_result=FNMeasure("MEAS:RFR:POW?",10)
150 !
160 ! Check the result of the function call.
170 !
180 IF Measure_result=9.E+99 THEN
190   PRINT "Measurement failed."
200 ELSE
210   PRINT "Power = ";Measure_result
220 END IF
230 END
240 !*****
250 ! Recommended Technique:
260 !*****
270 DEF FNMeasure(Query_command$,Time_out_value)
280   COM /Io_names/ INTEGER Inst_addr,Bus_addr
290   DISABLE
300   ON TIMEOUT Bus_addr,Time_out_value RECOVER Timed_out
310   OUTPUT Inst_addr;"TRIG:MODE:RETR SING;:TRIG:IMM"
320   OUTPUT Inst_addr;Query_command$
330   ENTER Inst_addr;Result
340   OUTPUT Inst_addr;"TRIG:MODE:RETR REP"
350   ENABLE
360   RETURN Result
370 Timed_out:!
380   ON TIMEOUT Bus_addr,Time_out_value GOTO Cannot_recover
390   CLEAR Inst_addr
400   OUTPUT Inst_addr;"TRIG:ABORT;MODE:RETR REP"
410   ENABLE
420   RETURN 9.E+99
430 Cannot_recover:!
440   DISP "Cannot regain control of Test Set."
450   STOP
460 FNEEND

```

## Comments for Recommended Routine

Table 2-1

Program Line Number	Comments
50	Send a Selected Device Clear (SDC) to the Test Set to put the HP-IB subsystem into a known state. This allows the control program to regain programmatic control of the Test Set if it is in an error state when the program begins to run.
60	Command the Test Set to abort the currently executing measurement cycle. This will force the Test Set to stop waiting for any measurement results to be available from measurements which may be in an invalid state when the program begins to run.
290	Turn event initiated branches off (except ON END, ON ERROR and ON TIMEOUT) to ensure that the Measure function will not be exited until it is finished.
300	Set up a timeout for any I/O activity on the HP-IB. This will allow the function to recover if the bus hangs for any reason.
310	Set the triggering mode to single followed by a trigger immediate command. This ensures that a new measurement cycle will be started when the TRIG:IMM command is sent. This sequence, that is: set to single trigger and then send a trigger command, guarantees that the measurement result returned to the ENTER statement will accurately reflect the state of the DUT when the TRIG:IMM command was sent. The 'IMM' keyword is optional.
320	Send the query command passed to the Measure function to the Test Set.
330	Read the measurement result.
340	Set the trigger mode to repetitive retriggering. Setting the trigger mode to repetitive will be implementation dependent.
350	Re-enable event initiated branching. If any event initiated branches were logged while the Measure function was executing they will be executed when system priority permits.
360	Exit the Measure function and return the result value.
370	The following lines of code handle the case where the request for a measurement result has timed out.
380	Set up a timeout for any I/O activity on the HP-IB while the control program is trying to regain control of the Test Set. This will allow the function to gracefully stop program execution if the control program cannot regain control of the Test Set. This timeout should only occur if there is some type of hardware failure, either in the Test Set or the external controller, which prevents them from communicating via HP-IB.
390	Send a Selected Device Clear (SDC) to the Test Set to put the HP-IB subsystem into a known state. This allows the control program to regain programmatic control of the Test Set.



<b>Program Line Number</b>	<b>Comments</b>
400	Command the Test Set to abort the currently executing measurement cycle. Set the trigger mode back to repetitive retriggering. Setting the Test Set back to repetitive retriggering will be implementation dependent.
410	Re-enable event initiated branching. If any event initiated branches were logged while the Measure function was executing they will be executed when system priority permits.
420	Exit the Measure function and return a result value of 9.E+99.
430	The following lines of code handle the case where the control program cannot regain control of the Test Set. The actions taken in this section of the code will be implementation dependent. For the example case a message is displayed to the operator and the program is stopped.
440	Display a message to the operator that the control program cannot regain control of the Test Set.
450	Stop execution of the control program.

## HP BASIC 'MAV' Example Program

The following HP RMB example program demonstrates a technique which can be used in situations where a 32.767 measurement result timeout value is not adequate.

Measurement result timeout value is defined to mean the amount of time the control program is willing to wait for the Test Set to return a valid measurement result to the control program.

The technique uses the MAV (Message Available) bit in the Test Set's HP-IB Status Byte to determine when there is data in the Output Queue. A polling loop is used to query the Status byte. The timeout duration for returning the measurement result is handled by the polling loop. An HP-IB interface activity timeout is also set up to handle time-outs resulting from problems with the HP-IB interface.

Lines 10 thru 230 in this example set up a measurement situation to demonstrate the use of the recommended technique. The recommended technique is exemplified in the Measure Function.

---

### NOTE

Lines 50 and 60 should be included in the beginning of all control program. These lines are required to ensure that the Test Set is properly reset. This covers the case where the program was previously run and was stopped with the Test Set in an error condition.

---

## MAV Example

```

10 COM /Io_names/ INTEGER Inst_addr,Bus_addr
20 CLEAR SCREEN
30 Inst_addr=714
40 Bus_addr=7
50 CLEAR Inst_addr
60 OUTPUT Inst_addr;"TRIG:ABORT"
70 OUTPUT Inst_addr;"*RST"
80 OUTPUT Inst_addr;"DISP RFAN"
90 !
100 ! Execute a call to the Measure function with a request to measure RF
110 ! power. The time out value is specified as 50 seconds. The value
120 ! returned by the function is assigned to the variable Measure_result.
130 !
140 Measure_result=FNMeasure("MEAS:RFR:POW?",50)
150 !
160 ! Check the result of the function call.
170 !
180 IF Measure_result=9.E+99 THEN
190 PRINT "Measurement failed."
200 ELSE
210 PRINT "Power = ";Measure_result
220 END IF
230 END
240 !*****
250 ! Recommended Technique:
260 !*****
270 DEF FNMeasure(Query_command$,Time_out_value)
280 COM /Io_names/ INTEGER Inst_addr,Bus_addr
290 DISABLE
300 ON TIMEOUT Bus_addr,5 GOTO Timed_out
310 OUTPUT Inst_addr;"TRIG:MODE:RETR SING::TRIG:IMM"
320 OUTPUT Inst_addr;Query_command$
330 Start_time=TIMEDATE
340 REPEAT
350 WAIT .1
360 Status_byte=SPOLL(Inst_addr)
370 IF BIT(Status_byte,4) THEN
380 ENTER Inst_addr;Result
390 OUTPUT Inst_addr;"TRIG:MODE:RETR REP"
400 ENABLE
410 RETURN Result
420 END IF
430 UNTIL TIMEDATE-Start_time>=Time_out_value
440 Timed_out:!
450 ON TIMEOUT Bus_addr,5 GOTO Cannot_recover
460 CLEAR Inst_addr
470 OUTPUT Inst_addr;"TRIG:ABORT;MODE:RETR REP"
480 RETURN 9.E+99
490 Cannot_recover: !
500 DISP "Cannot regain control of Test Set."
510 STOP
520 FNEEND

```

## Comments for Recommended Routine

**Table 2-2**                      Comments for Measure Function from MAV Example Program

<b>Program Line Number</b>	<b>Comments</b>
50	Send a Selected Device Clear (SDC) to the Test Set to put the HP-IB subsystem into a known state. This allows the control program to regain programmatic control of the Test Set if it is in an error state when the program begins to run.
60	Command the Test Set to abort the currently executing measurement cycle. This will force the Test Set to stop waiting for any measurement results to be available from measurements which may be in an invalid state when the program begins to run.
290	Turn event initiated branches off (except ON END, ON ERROR and ON TIMEOUT) to ensure that the Measure function will not be exited until it is finished.
300	Set up a 5 second timeout for any I/O activity on the HP-IB. This will allow the function to recover if the bus hangs for any reason. The length of the timeout will be implementation dependent.
310	Set the triggering mode to single followed by a trigger immediate command. This ensures that a new measurement cycle will be started when the TRIG:IMM command is sent. This sequence, that is: set to single trigger and then send trigger command, guarantees that the measurement result returned to the ENTER statement will accurately reflect the state of the DUT when the TRIG:IMM command was sent. The 'IMM' keyword is optional.
320	Send the query command passed to the Measure function to the Test Set.
330	Establish a start time against which to compare the measurement result timeout value passed to the Measure function.
340	Start the status byte polling loop.
350	Allow the Test Set some time (100 milliseconds) to process the measurement. When polling the Test Set the polling loop must give the Test Set time to process the requested measurement. Since HP-IB command processing has a higher system priority within the Test Set than measurement functions, constantly sending HP-IB commands will result in longer measurement times.
360	Perform a serial poll to read the Status Byte from the Test Set. A serial poll is used because the *STB Common Command cannot be processed by the Test Set while a query is pending. Sending the *STB command will cause an 'HP-IB Error: -410 Query INTERRUPTED' error.
370	Check bit 4, the Message Available bit (MAV), to see if it is set to '1'. If it is, then the requested measurement result is ready.
380	Read the measurement result.
390	Set the trigger mode to repetitive retriggering. Setting the trigger mode to repetitive will be implementation dependent.

<b>Program Line Number</b>	<b>Comments</b>
400	Re-enable event initiated branching. If any event initiated branches were logged while the Measure function was executing they will be executed when system priority permits.
410	Exit the Measure function and return the result value.
430	Check to see if the measurement result time out value has been equaled or exceeded. If it has the polling loop will be exited.
440	The following lines of code handle the case where the request for a measurement result has timed out because the polling loop has completed with no result available.
450	Set up a timeout for any I/O activity on the HP-IB while the control program is trying to regain control of the Test Set. This will allow the function to gracefully stop program execution if the control program cannot regain control of the Test Set. This timeout should only occur if there is some type of hardware failure, either in the Test Set or the external controller, which prevents them from communicating via HP-IB.
460	Send a Selected Device Clear (SDC) to the Test Set to put the HP-IB subsystem into a known state. This allows the control program to regain programmatic control of the Test Set.
470	Command the Test Set to abort the currently executing measurement cycle. Set the trigger mode back to repetitive retriggering. Setting the Test Set back to repetitive retriggering will be implementation dependent.
480	Exit the Measure function and return a result value of 9.E+99.
490	The following lines of code handle the case where the control program cannot regain control of the Test Set. The actions taken in this section of the code will be implementation dependent. For the example case a message is displayed to the operator and the program is stopped.
500	Display a message to the operator that the control program cannot regain control of the Test Set.
510	Stop execution of the control program.



---

## **3 HP-IB Command Guidelines**

## Sequential and Overlapped Commands

IEEE 488.2 makes the distinction between sequential and overlapped commands. Sequential commands complete their task before execution of the next command can begin. Overlapped commands can run concurrently, that is, a command following an overlapped command may begin execution while the overlapped command is still in progress. All commands in the Test Set are sequential.

The processing architecture of the Test Set allows it to accept commands through the HP-IB while it is executing commands already parsed into its command buffer. While this may appear to be overlapped, commands are always executed sequentially in the order received.

The process of executing a command can be divided into three steps:

1. Command is accepted from HP-IB and checked for proper structure and parameters.
2. Commands is sent to instrument hardware.
3. Instrument hardware fully responds after some time,  $\Delta t$ .

For example, in programming the Test Set's RF Signal Generator it takes  $< 150$  ms after receipt of the frequency setting command for the output signal to be within 100 Hz of the desired frequency. In the Test Set, commands are considered to have "completed their task" at the end of step 2. In manual operation all displayed measurement results take into account the instrument hardware's response time. When programming measurements through HP-IB the Triggering mode selected will determine whether the instrument's response time is accounted for automatically or if the control program must account for it. Refer to "[Triggering Measurements](#)" on page 103 for a discussion of the different Trigger modes available in the Test Set and their affect on measurement results.



---

## Guidelines for Operation

The following topics discuss rules and guidelines for controlling the Test Set through HP-IB.

### Command Names

All command names of more than four characters have an alternate abbreviated form using only upper case letters and, in some cases, a single numeral. The commands are not case sensitive. Upper and lower case characters can be used for all commands.

For example, to set the destination of AF Generator 1 to Audio Out, any of the following command strings are valid:

#### Example

```
AFGENERATOR1:DESTINATION 'AUDIO OUT'
```

or

```
afgenerator1:destination 'audio out'
```

or

```
afg1:dest 'audio out'
```

or

```
AFG1:DEST 'AUDIO OUT'
```

or

```
Afg1:Dest 'Audio OUT'
```

## Command Punctuation

---

**NOTE**

### Programming Language Considerations

The punctuation rules for the Test Set's HP-IB commands conform to the IEEE 488.2 standard. It is possible that some programming languages used on external controllers may not accept some of the punctuation requirements. It is therefore necessary that the equivalent form of the correct punctuation, as defined by the language, be used for HP-IB operation. Improper punctuation will result in

```
.HP-IB Error: -102 Syntax Error
```

---

### Using Quotes for String Entries

Quotation marks ' and " are used to select a non-numeric field setting. The value is entered into the command line as a quoted alphanumeric string.

Quotes are used with all Underlined (toggling) and One-of-many (menu choice) fields.

For example, to set the RF Generator's Output Port field to Dupl (duplex), the Dupl would be entered into the command string.

#### Example

```
RFG:OUTP 'Dupl'
```

or

```
RFG:OUTP "Dupl"
```

### Using Spaces

When changing a field's setting, a space must always precede the setting value in the command string, regardless of the field type (command<space>value).

#### Example

```
RFG:FREQ<space>850MHZ
```

```
RFG:ATT<space>'OFF'
```

## Using Colons to Separate Commands

The HP-IB command syntax is structured using a control hierarchy that is analogous to manual operation.

The control hierarchy for making a manual instrument setting using the front-panel controls is as follows: first the screen is accessed, then the desired field is selected, then the appropriate setting is made. HP-IB commands use the same hierarchy. The colon (:) is used to separate the different levels of the command hierarchy.

For example, to set the AF Analyzer input gain to 40 dB, the following command syntax would be used:

### Example

```
DISP AFAN
AFAN:INP:GAIN '40 dB'
```

## Using the Semicolon to Output Multiple Commands

Multiple commands can be output from one program line by separating the commands with a semicolon (;). The semicolon tells the Test Set's HP-IB command parser to back up one level of hierarchy and accept the next command at the same level as the previous command.

For example, on one command line, it is possible to

1. access the AF ANALYZER screen,
2. set the AF Analyzer's Input to AM Demod
3. set Filter 1 to 300 Hz HPF
4. set Filter 2 to 3kHz LPF

### Example

```
DISP AFAN;AFAN:INP 'AM DEMOD';FILT1 '300Hz HPF';FILT2 '3kHz LPF'
```

The semicolon after the "DISP AFAN" command tells the Test Set's HP-IB command parser that the next command is at the same level in the command hierarchy as the display command. Similarly, the semicolon after the INP 'AM DEMOD' command tells the command parser that the next command (FILT1 '300Hz HPF') is at the same command level as the INP 'AM DEMOD' command.

## Using the Semicolon and Colon (;:) to Output Multiple Commands

A semicolon followed by a colon (;:) tells the HP-IB command parser that the next command is at the top level of the command hierarchy. This allows commands from different instruments to be output on one command line. The following example sets the RF Analyzer's tune frequency to 850 MHz, and then sets the AF Analyzer's input to FM Demod.

### Example

```
RFAN:FREQ 850MHZ;:AFAN:INP 'FM DEMOD'
```

## Using Question Marks to Query Setting or Measurement Fields

The question mark (?) is used to query (read-back) an instrument setting or measurement value. To generate the query form of a command, place the question mark immediately after the command. Queried information must be read into the proper variable type within the program context before it can be displayed, printed, or used as a numeric value in the program.

Queried information is returned in the same format used to set the value: queried numeric fields return numeric data; quoted string fields return quoted string information.

For example, the following BASIC language program statements query the current setting of the AFGen 1 To field:

### Example

```
!Query the AFGen1 To field  
OUTPUT 714;"AFG1:DEST?"  
!Enter queried value into a string variable.  
ENTER 714;Afg1_to$
```

## Specifying Units-of-Measure for Settings and Measurement Results

Numeric settings and measurement results in the Test Set can be displayed using one or more units-of-measure (V, mV, Hz, kHz, MHz...). When operating the Test Set manually, the units-of-measure can be easily changed to display measurement results and field settings in the most convenient format. HP-IB operation is similar to manual operation in that the units-of-measure used to display numeric data can be programmatically changed to the most convenient form.

---

**NOTE** When querying measurements or settings through HP-IB, the Test Set always returns numeric values in HP-IB Units or Attribute Units, regardless of the current Display Units setting. Refer to “[HP-IB Units \(UNITS\)](#)” on page 73 and “[Attribute Units \(AUNits\)](#)” on page 76 for further information.

---

There are three sets of units-of-measure used in the Test Set: Display Units, HP-IB Units, and Attribute Units. Writing correct HP-IB programs requires an understanding of how the Test Set deals with these different sets of units-of-measure.

## Display Units (DUNits)

Display Units are the units-of-measure used by the Test Set to display numeric data (field settings and measurement results) on the front-panel *CRT display*. For example, the RF Generator's frequency can be displayed in Hz, kHz, MHz and GHz. Similarly, the measured TX Frequency can be displayed in Hz, kHz, MHz and GHz.

When evaluating an entered value for a numeric field, the Test Set interprets the data it receives in terms of the Display Units currently set. For example, if the Display Units for the RF Gen Freq field are set to GHz and the operator tries to enter 500 into the field, an Input value out of range error is generated since the Test Set interpreted the value as 500 GHz which is outside the valid frequency range of the Test Set.

**Changing Display Units.** Use the DUNits command to change the units-of-measure used by the Test Set to display any field setting or measurement result. For example, to change the Display Units setting for the TX Power measurement field from W to dBm, the following command would be used:

### Example

```
MEAS:RFR:POW:DUN DBM
```

### GHz

```
:MEAS:RFR:FREQ:ABS:DUN GHZ
```

### MHz

```
:MEAS:RFR:FREQ:ABS:DUN MHZ
```

### kHz

```
:MEAS:RFR:FREQ:ABS:DUN KHZ
```

### Hz

```
:MEAS:RFR:FREQ:ABS:DUN HZ
```

### ppm

```
:MEAS:RFR:FREQ:ERR:DUN PPM
```

### %D

```
:MEAS:RFR:FREQ:ERR:DUN PCTDIFF
```

**V**

:MEAS:RFR:POW:DUN V

**mV**

:MEAS:RFR:POW:DUN MV

**$\mu$ V**

:RFG:AMPL:DUN  $\mu$ V

**dB $\mu$ V**

:RFG:AMPL:DUN DB $\mu$ V

**W**

:MEAS:RFR:POW:DUN W

**mW**

:MEAS:RFR:POW:DUN MW

**dBm**

:MEAS:RFR:POW:DUN DBM

**db**

:MEAS:AFR:DISTN:DUN DB

**%**

:MEAS:AFR:DISTN:DUN PCT

**S**

:DEC:FGEN:GATE:DUN S

**ms**

:DEC:FGEN:GATE:DUN MS

**Reading Back Display Units Setting.** Use the Display Units query command, DUNits?, to read back the current Display Units setting. For example, the following BASIC language program statements query the current Display Units setting for the TX Power measurement:

**Example**

```
!Query Display Units setting for TX Power measurement.  
OUTPUT 714;"MEAS:RFR:POW:DUNits?"  
!Enter the returned value into a string variable.  
ENTER 714;A$
```

The returned units-of-measure will be whatever is shown on the Test Set's front-panel display for the TX Power measurement: dBm, V, mV, dBuV, or W. All returned characters are in upper case. For example, if dBuV is displayed, DBUV is returned.

**Guidelines for Display Units.**

- When querying a field's setting or measurement result through HP-IB, the Test Set always returns numeric values in HP-IB Units or Attribute Units, regardless of the field's current Display Units setting.
- The Display Units for a field's setting or measurement result can be set to any valid unit-of-measure, regardless of the field's HP-IB Units or Attribute Units.
- The Display Units setting for a field's setting is not affected when changing the field's value through HP-IB.

For example, if the AFGen1 Freq Display Units are set to kHz, and the command AFG1:FREQ 10 HZ is sent to change AFGen1's frequency to 10 Hz, the Test Set displays 0.0100 kHz; not 10 Hz.



## HP-IB Units (UNITs)

HP-IB Units are the units-of-measure used by the Test Set when sending numeric data (field settings and measurement results) through HP-IB, and the default units-of-measure for receiving numeric data (field settings and measurement results) through HP-IB. Changing HP-IB Units has no affect on the Display Units or Attribute Units settings. [Table 3-1](#) lists the HP-IB Units used in the Test Set.

**Table 3-1**

**HP-IB Units**

Parameter	Unit of Measure
Power	Watts (W) or dBm (DBM)
Amplitude	Volts (V), or dB $\mu$ V (DBUV)
Frequency	Hertz (Hz)
Frequency Error	Hertz (HZ) or parts per million (PPM)
Time	Seconds (S)
Data Rate	Bits per second (BPS)
Current	Amperes (A)
Resistance	Ohms (OHM)
Relative Level	decibels (DB) or percent (PCT)
Marker Position	Division (DIV)
FM Modulation	Hertz (HZ)
AM Modulation	Percent (PCT)

Use the UNITs? command to determine the HP-IB Units for a measurement result or field setting (refer to [“Reading-Back HP-IB Units”](#) on page 74 for more information).

**Changing HP-IB Units.** Use the UNITS command to change the HP-IB Units setting for selected measurement or instrument setup fields. Only the HP-IB units for power, relative level, and frequency error can be changed. Table 3-2 lists the measurement and instrument setup fields which have changeable HP-IB Units.

**Table 3-2 HP-IB Units That Can Be Changed**

Function	Available HP-IB Units
TX Power measurement	W or DBM
Adjacent Channel Power LRATio, URATio LLEVel, ULEVel	DB or PCT W or DBM
SINAD measurement	DB or PCT
DISTN measurement	DB or PCT
SNR measurement	DB or PCT
RF Generator Amplitude	W or DBM or V or DBUV
Frequency Error	HZ or PPM

For example, the following BASIC language program statements change the HP-IB Units for the TX Power measurement from W to dBm:

**Example**

```
OUTPUT 714;"MEAS:RFR:POW:UNIT DBM"
```

**Reading-Back HP-IB Units.** Use the UNITS? command to read back the current HP-IB Units setting for a measurement or instrument setup field. For example, the following BASIC language program statements read back the current HP-IB Units setting for the TX Power measurement:

**Example**

```
!Query the current HP-IB Units setting for TX Power.
OUTPUT 714;"MEAS:RFR:POW:UNIT?"
!Enter the returned value into a string variable.
ENTER 714;A$
```

### Guidelines for HP-IB Units.

- When setting the value of a numeric field (such as `AFGen1 Freq`), any non-HP-IB Unit unit-of-measure must be specified in the command string, otherwise the current HP-IB Unit is assumed by the Test Set.

For example, if the command `RFG:FREQ 900` is sent through HP-IB, the Test Set will interpret the data as 900 Hz, since HZ is the HP-IB Unit for frequency. This would result in an `Input value out of range` error. Sending the command `RFG:FREQ 900 MHZ` would set the value to 900 MHz.

- When querying measurements or settings through HP-IB, the Test Set always returns numeric values in HP-IB units, regardless of the current Display Unit setting. Numeric values are expressed in scientific notation.

For example, if the `TX Frequency` measurement is displayed as 150.000000 MHz on the Test Set, the value returned through HP-IB is `1.5000000E+008` ( $1.5 \times 10^8$ ). Converting the returned value to a format other than scientific notation must be done programmatically.

### Attribute Units (AUNits)

Attribute Units are the units-of-measure used by the Test Set when sending or receiving numeric data through HP-IB for the MEASure commands: REFerence, METer (HEND, LEND, INT), HLIMit and LLIMit (refer to “Number Measurements Syntax” in the *HP-IB Syntax Reference Guide* for further details). These measurement commands are analogous to the front-panel Data Function keys: REF SET, METER, HI LIMIT and LO LIMIT respectively. Attribute Units use the same set of units-of-measure as the HP-IB Units (except Frequency Error), but are only used with the MEASure commands: REFerence, METer (HEND, LEND, INT), HLIMit and LLIMit. [Table 3-3](#) lists the Attribute Units used in the Test Set.

**Table 3-3** Attribute Units

Parameter	Unit of Measure
Power	Watts (W) or dBm (DBM)
Amplitude	Volts (V)
Frequency	Hertz (Hz)
Time	Seconds (S)
Data Rate	Bits per second (BPS)
Current	Amperes (A)
Resistance	Ohms (OHM)
Relative Level	decibels (DB) or percent (PCT)
Marker Position	Division (DIV)
FM Modulation	Hertz (HZ)
AM Modulation	Percent (PCT)

**Default Data Function Values.** The majority of measurements made with the Test Set can be made using the Data Functions: REF SET, METER, AVG, HI LIMIT and LO LIMIT. Measurements which can be made using the Data Functions have a cross-reference with the comment “See Number Measurement Syntax” in their syntax. If one or more of the Data Functions are not available to that measurement, the Data Function(s) not available will be listed in the syntax.

For each measurement that can be made using the Data Functions, there is a default set of values for each Data Function for that measurement.

For example, the Audio Frequency Analyzer Distortion measurement can be made using all of the Data Functions. This would include REF SET, METER, AVG, HI LIMIT and LO LIMIT. A complete listing of the Distortion measurement's Data Functions and their default values would appear as follows:

- The Attribute units are: PCT
- The number of Averages is: 10
- The Average state is: 0
- The Reference value is: 1
- The Reference Display units are: PCT
- The Reference state is: 0
- The High Limit is: 0
- The High Limit Display units are: PCT
- The High Limit state is: 0
- The Low Limit is: 0
- The Low Limit Display units are: PCT
- The Low Limit state is: 0
- The Meter state is: 0
- The Meter high end setting is: 10
- The Meter high end Display units are: PCT
- The Meter low end setting is: 0
- The Meter low end Display units are: PCT
- The Meter interval is: 10

The Data Functions are set to their default values whenever

- the power is cycled on the Test Set
- the front-panel PRESET key is selected
- the \*RST Common Command is received through HP-IB

**Changing Attribute Units.** The AUNits command can be used to change the Attribute Units setting for selected measurements. Only the Attribute Units for power and relative level measurements can be changed. [Table 3-4](#) lists the measurements which have changeable Attribute Units.

**Table 3-4 Measurements with Attribute Units That Can Be Changed**

Function	Available Attribute Units
TX Power measurement	W or DBM
Adjacent Channel Power	
LRATio, URATio	DB or PCT
LLEVel, ULEVel	W or DBM
SINAD measurement	DB or PCT
DISTN measurement	DB or PCT
SNR measurement	DB or PCT

Before changing the Attribute Units for a selected measurement, the Test Set verifies that all Data Function values can be properly converted from the current unit-of-measure to the new unit-of-measure. The following Data Function settings are checked:

- the Reference value
- the High Limit
- the Low Limit
- the Meter's high end setting
- the Meter's low end setting
- the Meter's interval

If it is not possible to properly convert all the values to the new unit-of-measure, the Attribute Units are not changed and the following error is generated: `HP-IB Error: HP-IB Units cause invalid conversion of attr.` This error is most often encountered when one of the Data Function values listed above is set to zero. If this error is encountered, the programmer must change the Data Function settings to values that can be converted to the new units-of-measure before sending the `:AUNits` command to the Test Set.

For example, the following BASIC language program statements

1. reset the Test Set
2. set the Data Function default zero values to non-zero values
3. set the Attribute Units to DB
4. then query the value of each Data Function

The units of measure for the returned values will be DB.

## Display Units and HP-IB Units are not affected when changing Attribute Units.

### Example

```

!Reset the Test Set
OUTPUT 714;"*RST"
!Set HIgh LIMIT value to 15
OUTPUT 714;"MEAS:AFR:DIST:HLIM:VAL 15"
!Set LOw LIMIT value to 1
OUTPUT 714;"MEAS:AFR:DIST:LLIM:VAL 1"
!Set the Meter Lo End value to 1
OUTPUT 714;"MEAS:AFR:DIST:MET:LEND 1"
!Set Attribute Units for Distortion measurement to DB
OUTPUT 714;"MEAS:AFR:DIST:AUN DB"
!Query the REFEreence SET value
OUTPUT 714;"MEAS:AFR:DIST:REF:VAL?"
!Read the REFEreence SET value into variable Ref_set_val
ENTER 714;Ref_set_val
!Query the HIgh LIMIT value
OUTPUT 714;"MEAS:AFR:DIST:HLIM:VAL?"
!Read the HIgh LIMIT value into variable Hi_limit_val
ENTER 714;Hi_limit_val
!Query the LOw LIMIT value
OUTPUT 714;"MEAS:AFR:DIST:LLIM:VAL?"
!Read the LOw LIMIT value into variable Lo_limit_val
ENTER 714;Lo_limit_val
!Query the Meter HI End value
OUTPUT 714;"MEAS:AFR:DIST:MET:HEND?"
!Read the Meter HI End value into variable Met_hiend_val
ENTER 714;Met_hiend_val
!Query the Meter LO End value
OUTPUT 714;"MEAS:AFR:DIST:MET:LEND?"
!Read the Meter LO End value into variable Met_loend_val
ENTER 714;Met_loend_val
!Query the Meter interval
OUTPUT 714;"MEAS:AFR:DIST:MET:INT?"
!Read the Meter interval into! variable Met_int_val
ENTER 714;Met_int_val

```

### **Reading-back Attribute Units.**

Use the AUNits? command to read back the Attribute Units setting for the selected measurement. For example, the following BASIC language program statements show how the AUNits? command can be used to read-back a Distortion REFERENCE SET level:

#### **Example**

```
!Query the REFERENCE SET value for the Distortion measurement
OUTPUT 714;"MEAS:AFR:DIST:REF:VAL?"

!Read the REFERENCE SET value into variable Ref_set_val
ENTER 714;Ref_set_val

!Query the Attribute Units setting for the Distortion measurement
OUTPUT 714;"MEAS:AFR:DIST:AUN?"

!Read the Attribute Units setting into string variable Attribute_set$
ENTER 714;Attribute_set$

!Print out the variables in the form <VALUE><UNITS>
PRINT Ref_set_val;Attribute_set$
```

**If a reference of 25% is set, 25 PCT would be printed.**



### Guidelines for Attribute Units.

- When setting the value of measurement functions REFerence, METer, HLIMit and LLIMit through HP-IB, a non-Attribute Unit unit-of-measure must be specified in the command string, otherwise the current Attribute Unit is assumed by the Test Set.

For example, if the Test Set is in a RESET condition and the command MEAS:AFR:DIST:REF:VAL 10 is sent through HP-IB, the Test Set will interpret the data as 10%, since % is the RESET Attribute Unit for the Distortion measurement. Sending the command, MEAS:AFR:DIST:REF:VAL 10 DBM, would set the REFerence SET value to 10 dB.

- When querying measurement functions REFerence, METer, HLIMit and LLIMit through HP-IB, the Test Set always returns numeric values in Attribute Units, regardless of the current Display Units or HP-IB Units settings. Numeric values are expressed in scientific notation.

For example, if the REF SET measurement function is displayed as 25% on the Test Set, the value returned through HP-IB is +2.50000000E+001 ( $2.5 \times 10^1$ ). Converting the returned value to a format other than scientific notation must be done programmatically.

- Before changing the Attribute Units for a selected measurement, the Test Set verifies that all Data Function values can be properly converted from the current unit-of-measure to the new unit-of-measure. If it is not possible to properly convert all the values to the new unit-of-measure, the Attribute Units are not changed and the following error is generated: HP-IB Error: HP-IB Units cause invalid conversion of attr.

## Using the STATE Command

The STATE command corresponds to the front-panel ON/OFF key and is used to programmatically turn measurements, instrument functions, and data functions ON or OFF.

### Turning measurements, instrument functions and data functions ON/OFF

Use 1 or ON to turn measurements, instrument functions, or data functions ON. Use 0 or OFF to turn measurements, instrument functions, or data functions OFF.

For example, the following BASIC language statements illustrate the use of the STATE command to turn several measurements, instrument functions, and data functions ON and OFF:

#### Example

```
!Turn off FM source AFG1. *
OUTPUT 714;"AFG1:FM:STAT OFF"

!Turn off REFERENCE SET data function
OUTPUT 714;"MEAS:AFR:DISTN:REF:STAT OFF"

!Turn off TX Power measurement
OUTPUT 714;"MEAS:RFR:POW:STAT 0"

!Turn on REF SET measurement function for FM Deviation measurement
OUTPUT 714;"MEAS:AFR:FM:REF:STAT ON"
```

\*This assumes the AFGen1 To field is set to FM.

### Reading back the measurement, instrument function, or data function state

Use the query form of the command, STATE?, to determine the current state of a measurement, instrument function or data function. If a measurement, instrument function, or data function is queried, the returned value will be either a "1" (ON) or a "0" (OFF).

For example, the following BASIC language statements illustrate the use of the STATE? command to determine the current state of the TX Power measurement:

#### Example

```
!Query the state of the TX Power measurement
OUTPUT 714;"MEAS:RFR:POW:STAT?"

ENTER 714;State_on_off

IF State_on_off = 1 THEN DISP "TX Power Measurement is ON"
IF State_on_off = 0 THEN DISP "TX Power Measurement is OFF"
```

## **STATe Command Guidelines**

- Measurements that are displayed as numbers, or as analog meters using the METER function, can be turned on and off.
- The data functions REFerence, METer, HLIMit, and LLIMit can be turned on and off.
- Any instrument function that generates a signal can be turned on and off. This includes the RF Generator, Tracking Generator, AF Generator 1, AF Generator 2, and the Signaling Encoder.
- The Oscilloscope's trace cannot be turned off.
- The Spectrum Analyzer's trace cannot be turned off.

## Sample HP-IB Program

The following program was written on an HP 9000 Series 300 controller using Hewlett-Packard Rocky Mountain BASIC (RMB). To run this program directly in the Test Set's IBASIC Controller make the following modifications:

1. Use exclamation marks (!) to comment-out lines 440, 450, and 460 (these commands not supported in IBASIC).
2. Change line 70 to Bus = 8 (internal HP-IB select code = 8).

### Example

```
10 !This program generates an FM carrier, measures and displays the
20 !deviation, and draws the modulation waveform from the
30 !oscilloscope to the CRT display. For demonstration purposes the
40 !carrier is generated and analyzed through the uncalibrated input
50 !path so that no external cables are required.
60 GCLEAR !Clear graphics display.
70 Bus=7 ! Interface select code of HP-IB interface
80 Dut=100*Bus+14 ! Default Test Set HP-IB address is 14
90 CLEAR Bus! Good practice to clear the bus
100 CLEAR SCREEN ! Clear the CRT
110 OUTPUT Dut;"*RST" ! Preset the Test Set
115 OUTPUT Dut;"DISP RFAN" !Display the RF ANALYZER screen
116 OUTPUT Dut;"RFAN:FREQ 100 MHZ" !Set the tune freq. to 100 MHZ
120 OUTPUT Dut;"DISP RFG" ! Display the RF GENERATOR screen
125 OUTPUT Dut;"RFG:FREQ 100 MHZ" ! Set the RF Gen frequency to 100 MHZ
130 OUTPUT Dut;"RFG:AMPL -26 DBM" ! Set RF Gen Amptd to -26 dBm
135 OUTPUT Dut;"AFG1:FM:STAT ON" !Turn on FM (3 kHz deviation, default)
136 OUTPUT Dut;"DISP AFAN" ! Display the AF ANALYZER screen
140 OUTPUT Dut;"AFAN:INP 'FM Demod'"
150 ! Set AF Analyzer's input to FM Demod
160 OUTPUT Dut;"AFAN:DET 'Pk+-Max'"
200 OUTPUT Dut;"TRIG"! Trigger all active measurements
210 OUTPUT Dut;"MEAS:AFR:FM?" ! Request an FM deviation measurement
220 ENTER Dut;Dev ! Read measured value into variable Dev
230 PRINT USING "K,D.DDD,K";"Measured FM = ",Dev/1000," kHz peak."
240 DISP "'Continue' when ready..." ! Set up user prompt
245 ! Set up interrupt on softkey 1
250 ON KEY 1 LABEL "Continue",15 GOTO Proceed
260 LOOP! Loop until the key is pressed
270 END LOOP
280 Proceed: OFF KEY! Turn off interrupt from softkey 1
```

```

290 DISP ""! Clear the user prompt
300 !
310 !Measure and plot oscilloscope trace to see the waveform shape.
320 DIM Trace(0:416)! Oscilloscope has 417 trace points
330 OUTPUT Dut;"DISP OSC" Display the Oscilloscope screen
340 OUTPUT Dut;"TRIG"! Trigger all active measurements
350 OUTPUT Dut;"MEAS:OSC:TRAC?"
360 !Request the oscilloscope trace
370 ENTER Dut;Trace(*)
380 ! Read the oscilloscope trace into array Trace(*)
390 ! CRT is (X,Y)=(0,0) in lower left corner
400 !to (399,179) upper right.
410 ! (Each pixel is about 0.02 mm wide by 0.03 mm tall, not square.)
420 ! Scale vertically for 0 kHz dev center-screen and +4 kHz dev top
430 ! of screen. Leave the next three lines for external control, or
440 ! comment them out for IBASIC (Test Set stand-alone) control.
450 !
460 PLOTTER IS CRT,"98627A"
470 !Your display may have a different specifier.
480 GRAPHICS ON!Enable graphics to plot the waveform.
490 WINDOW 0,399,0,179
500 !
510 PEN 1 !Turn on drawing pen
520 MOVE 0,89.5+Trace(0)/4000*89.5
530 FOR I=1 TO 416
540 DRAW I/416*399,89.5+Trace(I)/4000*89.5
550 NEXT I
560 END

```



---

## **4 IEEE Common Commands**

This chapter describes IEEE 488.2 common commands.

## IEEE 488.2 Common Commands

The IEEE 488.2 Standard defines a set of common commands which provide for uniform communication between devices on the HP-IB. These commands are common to all instruments which comply with the IEEE 488.2 Standard. These commands control some of the basic instrument functions, such as instrument identification, instrument reset, and instrument status reporting.

The following common commands are implemented in the Test Set:

**Table 4-1**

<b>Mnemonic</b>	<b>Command Name</b>
*CLS	Clear Status Command
*ESE	Standard Event Status Enable Command
*ESE?	Standard Event Status Enable Query
*ESR?	Standard Event Status Register Query
*IDN?	Identification Query
*OPC	Operation Complete Command
*OPC?	Operation Complete Query
*OPT?	Option Identification Query
*PCB	Pass Control Back Command
*RCL	Recall Command
*RST	Reset Command
*SAV	Save Command
*SRE	Service Request Enable Command
*SRE?	Service Request Enable Query
*STB?	Read Status Byte Query
*TRG	Trigger Command
*TST?	Self-Test Query
*WAI	Wait-to-Continue Command



---

## Common Command Descriptions

### \*IDN? (Identification Query)

The \*IDN? query causes a device to send its identification information over the bus. The Test Set responds to the \*IDN? command by placing its identification information, in ASCII format, into the Output Queue. The response data is obtained by reading the Output Queue into a string variable of length 72. The response data is organized into four fields separated by commas. The field definitions are described in [Table 4-2](#).

**Table 4-2** Device Identification

Field	Contents	Response from Test Set	Comments
1	Manufacturer	Hewlett-Packard	
2	Model	Depends upon Model of Test Set	
3	Serial Number	US12345678	ASCII character "0", decimal value 48, if not available
4	Firmware Revision Level	A.01.08	ASCII character "0", decimal value 48, if not available

---

**NOTE**

The Serial Number format can take one of two forms:

A = alpha character  
X = numeric character

The form returned will depend upon the manufacturing date of the Test Set being queried.

---

### Example BASIC program

#### Example

```
10 DIM A$(10)20 OUTPUT 714;"*IDN?"
30 ENTER 714;A$
40 PRINT A$
50 END
```

**\*OPT? (Option Identification Query)**

The \*OPT? command tells the Test Set to identify any reportable device options installed in the unit. The Test Set responds to the \*OPT? command by placing information which describes any reportable installed options into the Output Queue. The data is in ASCII format. The response data is obtained by reading the Output Queue into a string variable of length 255. The response data is organized into fields separated by commas. Some fields, such as the Filter Option field, have more than one valid string (only one is returned).

If an option is not installed, an ASCII character 0 (zero) is placed in the output string for that option. If an option is standard, it is not reported (an ASCII character 0 (zero) is not placed in the output string for that option). The length of the returned string can vary depending upon the Test Set being queried, installed options and standard options.

**Example BASIC program****Example**

```
10 DIM A$(255)20 OUTPUT 714;"*OPT?"
30 ENTER 714;A$
40 PRINT A$
50 END
```

**\*RST (Reset)**

The \*RST command resets the Test Set. When the \*RST command is received the majority of fields in the Test Set are “restored” to a default value, some fields are “maintained” at their current state and some are “initialized” to a known state. Refer to [“Instrument Initialization” on page 177](#) for further information. Other operational characteristics are also affected by the \*RST command as follows:

- All pending operations are aborted.
- The Test Set’s display screen is in the UNLOCKED state.
- Measurement triggering is set to TRIG:MODE:SETT FULL;RETR REP.
- Any previously received Operation Complete command (\*OPC) is cleared.
- Any previously received Operation Complete query command (\*OPC?) is cleared.
- The power-up self-test diagnostics are not performed.
- The contents of the SAVE/RECALL registers are not affected.
- Calibration data is not affected.
- The HP-IB interface is not reset (any pending Service Request is not cleared).
- All Enable registers are unaffected: Service Request, Standard Event, Communicate, Hardware #1, Hardware #2, Operation, Calibration, and Questionable Data/Signal.
- All Negative Transition Filter registers are unaffected: Communicate, Hardware #1, Hardware #2, Operational, Calibration, and Questionable Data/Signal.
- All Positive Transition Filter registers are unaffected: Communicate, Hardware #1, Hardware #2, Operational, Calibration, and Questionable Data/Signal.
- The contents of the RAM are unaffected.
- The contents of the Output Queue are unaffected.
- The contents of the Error Queue are unaffected.

**\*TST? (Self-Test Query)**

The \*TST? self-test query causes the Test Set to execute a series of internal self-tests and place a numeric response into the Output Queue indicating whether or not the Test Set completed the self-test without any detected errors. The response data is obtained by reading the Output Queue into a numeric variable, real or integer. Upon successful completion of the self-test the Test Set settings are restored to their values prior to receipt of the \*TST? command.

---

**NOTE**

---

Refer to the Test Set's *Assembly Level Repair* manual for further information on Power-Up Self Test Failure.

**Example BASIC program****Example**

```
10 INTEGER Slf_tst_respons20 OUTPUT 714;"*TST?"
30 ENTER 714;Slf_tst_respons
40 PRINT Slf_tst_respons$
50 END
```

**Example response****Example**

```
512
```

## \*OPC (Operation Complete)

The \*OPC command allows for synchronization between the Test Set and an external controller. The \*OPC command causes the Test Set to set bit 0, Operation Complete, in the Standard Event Status Register to the TRUE, logic 1, state when the Test Set completes all pending operations. Detection of the Operation Complete message can be accomplished by continuous polling of the Standard Event Status Register using the \*ESR? common query command. However, using a service request eliminates the need to poll the Standard Event Status Register thereby freeing the controller to do other useful work.

---

### NOTE

The Test Set contains signal generation and signal measurement instrumentation. The instrument control processor is able to query the signal measurement instrumentation to determine if a measurement cycle has completed. However, the instrument control processor is not able to query the signal generation instrumentation to determine if the signal(s) have settled. In order to ensure that all signals have settled to proper values, the instrument control processor initiates a one-second delay upon receipt of the \*OPC, \*OPC? and \*WAI commands. In parallel with the one-second timer the instrument control processor commands all active measurements to tell it when the measurement(s) are done. When all active measurements are done and the one-second timer has elapsed, the \*OPC, \*OPC? and \*WAI commands are satisfied.

If the \*OPC, \*OPC? or \*WAI common commands are used to determine when a measurement has completed and the measurement is either in the OFF State or unavailable (four dashed lines on CRT display “- - - -”), the \*OPC, \*OPC? or \*WAI command will never complete.

---

## Example BASIC program - Service Request

### Example

```
10 OUTPUT 714;"*SRE 32"
20 !Enable SRQ on events in the Standard Event Status Register
30 OUTPUT 714;"*ESE 1"
40 !Enable Operation Complete bit in Standard Event Status Register
50 ON INTR 7,15 CALL Srvic_e_interupt!Set up interrupt
60 ENABLE INTR 7;2 !Enable SRQ interrupts
70 OUTPUT 714;"DISP RFG;RFG:OUTP 'Dupl';AMPL 0 dBm;FREQ 320 MHz;*OPC"
80 LOOP!Dummy loop to do nothing
90 DISP "I am in a dummy loop."
100 END LOOP
110 END
120 SUB Srvic_e_interupt
130 PRINT "All operations complete."
140 ! Note:
150 ! This interrupt service routine is not complete.
160 ! Refer to the See "HP-IB Service Requests" on page 168. for
170 ! complete information.
180 SUBEND
```

The program enables bit 0 in the Standard Event Status Enable Register and also bit 5 in the Service Request Enable Register so that the Test Set will request service whenever the OPC event bit becomes true. After the service request is detected the program can take appropriate action. Refer to ["HP-IB Service Requests" on page 168](#) for further information.

## Example BASIC program - Polling the Standard Event Status Register

### Example

```
10 INTEGER Stdevnt_reg_val
20 OUTPUT 714;"DISP RFG;RFG:OUTP 'Dupl';AMPL 0 dBm;FREQ 320 MHz;*OPC"
30 LOOP
40 OUTPUT 714;"*ESR?" ! Poll the register
50 ENTER 714;Stdevnt_reg_val
60 EXIT IF BIT(Stdevnt_reg_val,0) ! Exit if Operation Complete bit set
70 END LOOP
80 PRINT "All operations complete."
90 END
```

## \*OPC? (Operation Complete Query)

The \*OPC? query allows for synchronization between the Test Set and an external controller by reading the Output Queue or by polling the Message Available (MAV) bit in the Status Byte Register. The \*OPC? query causes the Test Set to place an ASCII character, 1, into its Output Queue when the Test Set completes all pending operations. A consequence of this action is that the MAV bit in the Status Byte Register is set to the 1 state.

---

### NOTE

The Test Set contains signal generation and signal measurement instrumentation. The instrument control processor is able to query the signal measurement instrumentation to determine if a measurement cycle has completed. However, the instrument control processor is not able to query the signal generation instrumentation to determine if the signal(s) have settled. In order to ensure that all signals have settled to proper values, the instrument control processor initiates a one-second delay upon receipt of the \*OPC, \*OPC? and \*WAI commands. In parallel with the one-second timer the instrument control processor commands all active measurements to tell it when the measurement(s) are done. When all active measurements are done and the one-second timer has elapsed, the \*OPC, \*OPC? and \*WAI commands are satisfied.

If the \*OPC, \*OPC? or \*WAI common commands are used to determine when a measurement has completed and the measurement is either in the OFF State or unavailable (four dashed lines on CRT display “- - - -”), the \*OPC, \*OPC? or \*WAI command will never complete.

---

**Using the \*OPC? query by reading Output Queue**

Bit 4 in the Service Request Enable Register is set to a value of zero (disabled). The \*OPC? query is sent to the Test Set at the end of a command message data stream. The application program then attempts to read the \*OPC? query response from the Test Set's Output Queue. The Test Set will not put a response to the \*OPC? query into the Output Queue until the commands have all finished.

---

**NOTE**

Reading the response to the \*OPC? query has the penalty that both the HP-IB bus and the Active Controller handshake are in temporary holdoff state while the Active Controller waits to read the \*OPC? query response from the Test Set.

---

**Example BASIC program**

```
10 INTEGER Output_que_val
20 OUTPUT 714;"*SRE 0"! Disable Service Requests
30 OUTPUT 714;"DISP RFG;RFG:OUTP 'Dupl';AMPL 0 dBm;FREQ 320 MHz;*OPC?"
40 ENTER 714;Output_que_val
50 !Program will wait here until all operations complete
60 PRINT "All operations complete."
70 END
```



## Using the \*OPC? query using the MAV bit in the Status Byte

Bit 4 in the Service Request Enable Register is set to a value of 1 (enabled). The \*OPC? query is sent to the Test Set at the end of a command message data stream. The Test Set will request service when the MAV bit in the Status Byte register is set to the TRUE, logic 1, state. After the service request is detected the application program can take appropriate action. Refer to the [“HP-IB Service Requests” on page 168](#) for further information.

### Example BASIC program

```
10 OUTPUT 714; "*SRE 16"
20 !Enable SRQ on data available in Output Queue (MAV bit)
30 ON INTR 7,15 CALL Srvic_e_interupt ! Set up interrupt
40 ENABLE INTR 7;2 ! Enable SRQ interrupts
50 OUTPUT 714; "DISP RFG;RFG:OUTP 'Dupl';AMPL 0 dBm;FREQ 320
MHz;*OPC?"
60 LOOP ! Dummy loop to do nothing
70 DISP "I am in a dummy loop."
80 END LOOP
90 END
100 SUB Srvic_e_interupt
110 ENTER 714;Output_que_val!Read the 1 returned by the *OPC?
120 ! query command
130 PRINT "All operations complete."
140 ! Note:
150 ! This interrupt service routine is not complete.
160 ! Refer to the “HP-IB Service Requests” on page 168 for
170 ! complete information.
180 SUBEND
```

## \*WAI (Wait To Complete)

The \*WAI command stops the Test Set from executing any further commands or queries until all commands or queries preceding the \*WAI command have completed.

### Example BASIC statement

#### Example

```
OUTPUT 714: "DISP RFG;RFG:OUTP 'Dupl';*WAI;AMPL 0 dBm"
```

---

#### NOTE

The Test Set contains signal generation and signal measurement instrumentation. The instrument control processor is able to query the signal measurement instrumentation to determine if a measurement cycle has completed. However, the instrument control processor is not able to query the signal generation instrumentation to determine if the signal(s) have settled. In order to ensure that all signals have settled to proper values, the instrument control processor initiates a one-second delay upon receipt of the \*OPC, \*OPC? and \*WAI commands. In parallel with the one-second timer the instrument control processor commands all active measurements to tell it when the measurement(s) are done. When all active measurements are done and the one-second timer has elapsed, the \*OPC, \*OPC? and \*WAI commands are satisfied.

If the \*OPC, \*OPC? or \*WAI common commands are used to determine when a measurement has completed and the measurement is either in the OFF State or unavailable (four dashed lines on CRT display "- - - -"), the \*OPC, \*OPC? or \*WAI command will never complete.

---

## \*CLS (Clear Status)

The \*CLS command clears the contents (sets all bits to zero) of all Event Registers summarized in the Status Byte. The \*CLS command also empties all queues (removes all current messages) which are summarized in the Status Byte, except the Output Queue. The Status Byte Register is cleared and any pending service request is cleared. The following Event Registers are affected:

- Hardware 1 Status Register
- Hardware 2 Status Register
- Questionable Data/Signal Register
- Standard Event Status Register
- Operational Status Register
- Calibration Status Register
- Communicate Status Register
- Call Processing Status Register

The Following message queues are affected:

- Error Message Queue

---

### NOTE

The \*CLS command does not clear the contents of the Message Screen which is displayed on the CRT when the SHIFT RX keys are selected. This display is only cleared when the unit is powered on.

---

### **\*ESE (Standard Event Status Enable)**

The Test Set responds to the \*ESE command. See “[Status Reporting](#)” on page 122 for a detailed explanation of the \*ESE command.

### **\*ESE? (Standard Event Status Enable Query)**

The Test Set responds to the \*ESE? command. See “[Status Reporting](#)” on page 122 for a detailed explanation of the \*ESE? command.

### **\*ESR? (Standard Event Status Register Query)**

The Test Set responds to the \*ESR? command. See “[Status Reporting](#)” on page 122 for a detailed explanation of the \*ESR? command.

### **\*SRE (Service Request Enable)**

The Test Set responds to the \*SRE command. “[HP-IB Service Requests](#)” on page 168 for a detailed explanation of the \*SRE command.

### **\*SRE? (Service Request Enable Query)**

The Test Set responds to the \*SRE? command. “[HP-IB Service Requests](#)” on page 168 for a detailed explanation of the \*SRE? command.

### **\*STB? (Status Byte Query)**

The Test Set responds to the \*STB? command. “[Status Reporting](#)” on page 122 for a detailed explanation of the \*STB? command.

### **\*TRG (Trigger)**

The \*TRG command is equivalent to the IEEE 488.1 defined Group Execute Trigger (GET) message and has the same effect as a GET when received by the Test Set. The Test Set responds to the \*TRG command by triggering all currently active measurements.

## **\*PCB (Pass Control Back)**

The Test Set accepts the \*PCB command. “[Passing Control](#)” on page 187 for a detailed explanation of the \*PCB command.

## **\*RCL (Recall Instrument State)**

The \*RCL command restores the state of the Test Set from a file previously stored in battery-backed internal memory, on a PC card, or on an external disk. The \*RCL command is followed by a decimal number in the range of 0 to 99 which indicates which Test Set SAVE/RECALL file to recall. The mass storage location for SAVE/RECALL files is selected using the SAVE/RECALL field on the I/O CONFIGURE screen.

The \*RCL command cannot be used to recall files with names which contain non-numeric characters or a decimal number greater than 99. To recall SAVE/RECALL files saved with names which contain non-numeric characters or a decimal number greater than 99, use the REG:RECALL filename command.

## **\*SAV (Save Instrument State)**

The \*SAV command saves the present state of the Test Set into a file in battery-backed internal memory or on a PC card. The \*SAV command is followed by a decimal number in the range of 0 to 99 which indicates the name of the stored SAVE/RECALL file. The mass storage location for SAVE/RECALL files is selected using the SAVE/RECALL field on the I/O CONFIGURE screen.

The \*SAV command cannot be used to save the present state of the Test Set to a file with a name which contains non-numeric characters or a decimal number greater than 99. To save the present state of the Test Set to a file with a name which contains non-numeric characters or a decimal number greater than 99, use the REG:SAVE filename command.

IEEE Common Commands  
**\*SAV (Save Instrument State)**

---

# 5

## Triggering Measurements

This chapter gives you information about triggering your measurements. This includes the following topics:

- [“Arming Hardware-Triggered Measurements” on page 112](#)
- [“Default Trigger Mode” on page 107](#)
- [“Local/Remote Triggering Changes” on page 107](#)
- [“Measurement Pacing” on page 112](#)
- [“Trigger Commands” on page 108](#)
- [“Trigger Event” on page 104](#)
- [“Trigger Mode and Measurement Speed” on page 110](#)
- [“Trigger Modes” on page 105](#)

## Triggering Measurements

The measurement cycle is started (triggered) by the occurrence of a trigger event. The reliability and accuracy of the measurement result, as well as the speed of the measurement cycle are influenced by the trigger mode in effect at the time the trigger event occurs. Some modes are faster than others; some modes provide settling for signals that may contain transients. The best triggering mode to use will depend upon the measurement requirements (repeatability, accuracy and speed).

### Trigger Event

The Test Set starts a measurement cycle when a valid Trigger Event is received. A Trigger Event is analogous to telling the Test Set to “start the measurement now.” There are three commands that can be used to issue a Trigger Event to the Test Set through HP-IB:

- A Group Execute Trigger Command (GET) as defined by IEEE 488.1-1987
- A Trigger Common Command (\*TRG) as defined by IEEE 488.2-1987
- A :TRIGger:IMMediate Test Set command.

All three commands are equivalent and have the same effect when received by the Test Set. The Test Set responds to the three commands by triggering *all* currently active measurements. A measurement is defined as *active* if

- it is on the currently displayed screen
- it is in the ON state

From a programming perspective this means that the screen which contains the measurement of interest must be made available using the DISPlay command and that the measurement STATE must be ON.



## Trigger Modes

The Trigger Mode is defined by two parameters: retriggering and settling.

### Retriggering

Retriggering refers to what a measurement does once it has completed a measurement cycle. There are two options:

1. Single retriggering causes the measurement cycle to stop once a valid measurement result has been obtained. A valid trigger command must be received to start the measurement again. When a measurement cycle is completed, the values for all active measurements are held until another trigger command is received. This allows the control program to query a group of measurements that were triggered at the same time. This is the same functionality as the front-panel HOLD function.

When the trigger mode is set to single retriggering, consecutive queries of the same measurement (with no intervening trigger event) will return the same value. Measurements that rely on external signals or hardware-generated events (such as the DTMF Decoder) must be re-armed with a new trigger command before another measurement can be made.

2. Repetitive retriggering causes the measurement cycle to immediately start over once a valid measurement result has been obtained. No trigger event must be received to start the measurement again. Repetitive retriggering will cause measurements that rely on external signals or hardware generated events (such as the DTMF Decoder) to be re-armed upon completion of a measurement cycle (a valid measurement result has been obtained). When the trigger mode is set to repetitive retriggering, consecutive queries of the same measurement return new measured values.

---

#### NOTE

If a measurement cycle does not successfully obtain a valid measurement result, it will continue to try until it does or the measurement trigger is aborted. This is true for both retriggering modes.

---

## Settling

Settling refers to the amount of delay introduced to allow signal transients to propagate through the analysis chain and settle out.

There are two options:

1. Full settling introduces the appropriate delay for all signal transients which might have occurred at the front panel at just the same time as the trigger event, to pass through the analysis chain and settle out. Delays are also inserted to allow for internal hardware transients to settle.
2. Fast settling introduces no delay for internal or external signal transients to settle. The programmer must account for transient settling before issuing the Trigger Event.

---

### NOTE

There will still be delays introduced by autoranging. If you want to remove these delays, turn OFF autoranging and explicitly set the ranging amplifiers in the program. Delays introduced by the measurement processes themselves cannot be eliminated.

---

### NOTE

#### Bus Lock Up:

If a measurement cycle does not successfully obtain a valid measurement result, it will continue to try until it does or until the measurement trigger is aborted. This is true for both retriggering modes. This has the consequence that both the HP-IB bus and the Active Controller handshake are in a temporary holdoff state while the Active Controller waits to read the measurement result from the Test Set.

The control program should include measurement time-out routines that CLEAR the bus and ABORT the trigger if a measurement does not complete within a specified amount of time. This provides a method of preventing the bus from remaining in the temporary holdoff state indefinitely.

---

## Default Trigger Mode

The Trigger mode is set to FULL SETTling and REPetitive RETRiggering whenever

- the Test Set is powered on
- the PRESET key is selected
- the Test Set is put into LOCAL mode
- the Test Set is reset using the \*RST command
- the Test Set is put in remote mode and no other trigger mode is set

## Local/Remote Triggering Changes

### Local To Remote Transitions

The Test Set switches from Local to Remote mode upon receipt of the Remote message (REN bus line true and Test Set is addressed to listen). No instrument settings are changed by the transition from Local to Remote mode, but triggering is set to the state it was last set to in Remote mode (if no previous setting, the default is FULL SETTling and REPetitive RETRiggering).

When the Test Set makes a transition from local to remote mode, all currently active measurements are flagged as invalid causing any currently available measurement results to become unavailable. If the HP-IB trigger mode is :RETR REP then a new measurement cycle is started and measurement results will be available for all active measurements when valid results have been obtained. If the HP-IB trigger mode is :RETR SING then a measurement cycle must be started by issuing a trigger event. Refer to [“Triggering Measurements” on page 104](#) for more information.

### Remote To Local Transitions

The Test Set switches from Remote to Local mode upon receipt of the Local message (Go To Local bus message is sent and Test Set is addressed to listen) or receipt of the Clear Lockout/Set Local message (REN bus line false). No instrument settings are changed by the transition from Remote to Local mode, but triggering is reset to FULL SETTling and REPetitive RETRiggering.

## Trigger Commands

### **:TRIGger:IMMediate**

The :TRIGger:IMMediate command tells the Test Set to “start a measurement cycle now.” The type of triggering used depends on the trigger mode settings. This command is equivalent to a Group Execute Trigger Command (GET) as defined by IEEE 488.1-1987 or a Trigger Common Command (\*TRG) as defined by IEEE 488.2-1987. The IMMediate statement is implied and is optional.

#### **Syntax**

```
:TRIGger:IMMediate
```

#### **Example**

```
OUTPUT 714: "TRIG:IMM"
```

**or**

```
OUTPUT 714: "TRIG"
```

### **:ABORt**

The :ABORt command tells the Test Set to stop a currently executing measurement cycle and get ready for a new HP-IB command. If for any reason a valid measurement cannot be made, this command allows the control program to terminate the requested measurement and regain control of the Test Set.

#### **Syntax**

```
:TRIGger:ABORt
```

#### **Example**

```
OUTPUT 714: "TRIG:ABOR"
```

## **:MODE**

The **:MODE** command is used to set the Trigger Mode for all active measurements. The trigger mode is defined by two parameters: retriggering and settling.

### **Retriggering Syntax**

```
:TRIGger:MODE:RETRigger REPetitive
```

```
:TRIGger:MODE:RETRigger SINGle
```

### **Retriggering Examples**

```
OUTPUT 714;"TRIG:MODE:RETR REP"
```

```
OUTPUT 714;"TRIG:MODE:RETR SING"
```

### **Settling Syntax**

```
:TRIGger:MODE:SETTling FAST
```

```
:TRIGger:MODE:SETTling FULL
```

### **Settling Examples**

```
OUTPUT 714;"TRIG:MODE:SETT FAST"
```

```
OUTPUT 714;"TRIG:MODE:SETT FULL"
```

## Trigger Mode and Measurement Speed

There are two generalized scenarios which can be described for HP-IB triggering control. The first is to have the Test Set return measurement results as fast as possible and assume that the control program will handle all transient settling and value tolerance activities. The second scenario is to have the Test Set return the most reliable, accurate, fully settled measurement results that it can, even if it takes some time to do this.

### Trigger Mode Settings for Fastest Measurements

Use the following Test Set configuration and trigger mode settings for the fastest possible measurement speed. See [“Increasing Measurement Throughput” on page 114](#) for more information on improving measurement throughput.

1. Range hold all autoranging functions and set ranges through HP-IB. This avoids autoranging delays.
2. Use REPetitive RETRiggering. This avoids Trigger Event processing delays.
3. Use FAST SETTling. This avoids the signal transient settling delays.<sup>1</sup>
4. Turn off all measurements that are not required. This avoids any delays caused by contention for measurement resources within the Test Set.

---

1. Using FAST settling increases the possibility that transient signal conditions which occur during the measurement cycle will be included in the measurement result.

### **Trigger Mode Settings for Most Reliable Measurements**

Use the following Test Set configuration and trigger mode settings to get the most accurate, most reliable, fully settled measurement results. See [“Increasing Measurement Throughput”](#) on page 114 for more information on improving measurement throughput.

1. Turn on all autoranging functions. (This is the Test Set’s default turn-on and preset state.)
2. Use SINGLE RETRiggering.
3. Use FULL SETTling.
4. Individually trigger each measurement.

## Measurement Pacing

Measurement pacing can be accomplished by using the IEEE 488.2-1987 Common Commands \*OPC, \*OPC?, and \*WAI. These commands are implemented within the Test Set using the criteria that an operation has not completed until

- all active measurements have obtained at least one valid measurement result
- all signals generated by the Test Set are within specifications.

Refer to the “[Common Command Descriptions](#)” on page 89 and the IEEE 488.2-1987 Standard for more information on using these commands.

## Arming Hardware-Triggered Measurements

Some measurements require an external signal to trigger the measurement. These measurements require that the measurement be “armed” in order for it to be triggered by the external signal. The :TRIGger:IMMediate command is used to arm these types of measurements within the Test Set.

When the trigger mode is set to RETRigger SINGLE, the measurement must be re-armed after each measurement cycle.

When the trigger mode is set to RETRigger REPetitive, the measurement is continually re-armed after each measurement cycle.

---

### NOTE

#### Bus Lock Up:

If the required triggering signal is not received, or if the signal level is incorrect, the measurement will not trigger and the measurement cycle will not complete. If a measurement cycle does not successfully obtain a valid measurement result, it will continue to try until it does (an external trigger is detected) or until the measurement trigger is aborted. This is true for both retriggering modes. This has the consequence that both the HP-IB bus and the Active Controller handshake are in a temporary holdoff state while the Active Controller waits to read the measurement result from the Test Set.

The control program should include measurement time-out routines that CLEAR the bus and ABORT the trigger if a measurement does not complete within a specified amount of time. This provides a method of preventing the bus from remaining in the temporary holdoff state indefinitely.

---



---

## **6** **Advanced Operations**

## Increasing Measurement Throughput

Measurement throughput is defined as the number of measurements made per unit of time. When operating the Test Set in the Internal or External Automatic Control Mode, measurement throughput is influenced by measurement speed, measurement setup time, and execution speed of the control program. Each of these factors is, in turn, influenced by several parameters. The following sections discuss the parameters and their effect on measurement throughput.

### Optimizing Measurement Speed

Measurement speed is defined as the time required to complete one measurement cycle after receipt of a valid trigger event. Measurement speed is influenced by the following four parameters.

#### 1. Trigger Mode

The Trigger Mode affects the time-to-first-reading and the length of the measurement cycle and is defined by two parameters: retriggering and settling. Retriggering refers to what a measurement does once it has completed a measurement cycle. Settling refers to the amount of delay introduced to allow signal transients to propagate through the analysis chain and settle out. Refer to [“Triggering Measurements” on page 103](#) for information on Trigger Mode and its impact on measurement speed.

#### 2. Autoranging

The autoranging functions continuously calculate and adjust gain to provide the optimum instrument setup for each measurement. This results in greater measurement accuracy but increases measurement cycle time. The autoranging functions can be turned off to decrease the measurement cycle time.

Time-to-first-reading after making new settings is usually much slower than the repetitive reading rate once the first reading has been returned. The main contributor to first-reading measurement time is hardware autoranging. Hardware autoranging time can be eliminated by first establishing the expected AF and RF signal levels into the Test Set. With these signal levels present, the Test Set will autorange, allowing the operator to determine the attenuation and gain settings of the RF input attenuator as displayed in the RF ANALYZER screen, and to determine the various IF and audio gains as displayed in the AF ANALYZER screen. The attenuation and gain settings determined in manual mode should be recorded for use in writing the program.

In the control program, select Gain Control, Hold (default is Auto), and make the settings recorded in manual mode. When the control program runs, the signal levels into the Test Set need to remain relatively constant since autoranging has been disabled.

If the automatic functions are turned off, the control program must set the gain stages before triggering a measurement. The automatic functions can be turned off as follows:

Disable RF autoranging by setting the Input Atten field to Hold using the following command:

#### Example

```
:RFAN:ATT:MODE 'HOLD'
```

Disable AF autoranging by setting the Gain Cntl field to Hold using the following command:

#### Example

```
:AFAN:RANG 'HOLD'
```

### 3. Frequency Counter Gate Time

The frequency counter's gate time specifies how long the RF or AF frequency counter samples the signal before displaying the measured result. Short gate times measure instantaneous frequency and long gate times measure average frequency. The longer the gate time, the longer the measurement cycle. The proper gate time is determined by the measurement requirements. Use the following commands to set gate times:

For AF frequency measurements, set the AF Analyzer's gate time with the `AF Cnt Gate` field, using the following command:

#### Example

```
:AFAN:GTIM <value> MS
```

For RF frequency measurements, set the RF Analyzer's gate time with the `RF Cnt Gate` field, using the following command:

#### Example

```
:RFAN:GTIM <value> MS
```

### 4. Number of Active Measurements

The Test Set is capable of making many measurements simultaneously. Measurements are either in the active state (ON) or in the inactive state (OFF). When the Test Set receives a trigger event, all active measurements are triggered. A measurement cycle is complete when all active measurements have obtained a valid measurement result. To decrease the measurement cycle time, all unused measurements should be set to the inactive state (turned OFF). Turning OFF unused measurements will have the greatest impact on reading repetition rate. Use the `STATE` command to turn OFF all unneeded measurements on the displayed screen.

## Optimizing Measurement Setup Time

Measurement setup time is defined as the time required to configure an individual instrument within the Test Set to make a measurement.

In general there are two methodologies which can be used to setup individual instruments in the Test Set:

1. Set up every field every time a measurement is made.
2. Define a base instrument state and then modify it as needed for each measurement (always returning to the base state after finishing the measurement).

Defining a base instrument state requires fewer HP-IB transactions to set up an instrument (in the majority of cases) which in turn reduces measurement setup time.

## Optimizing the Execution Speed of the Control Program

Execution speed of the control program is defined as the time required to execute a given number of program lines.

Each time the HP-IB is accessed, a given amount of time is required to configure the devices on the bus for data transfer. Every time a BASIC or IBASIC OUTPUT or ENTER statement is executed this bus configuration time is incurred. The total amount of bus configuration time expended for a given number of program lines can be minimized by reducing the number of OUTPUT and ENTER statements used in the control program. This is accomplished by combining several commands into one HP-IB transaction. Execution speed of the control program is influenced by the use of compound commands and screen display time as described in the following paragraphs.

## Compound Commands for Combining OUTPUT Statements

To reduce the number of OUTPUT statements used to make the desired settings within one screen, string together multiple settings within one OUTPUT statement. This is accomplished using the ; (semicolon) separator and the ;; (semicolon colon) separator.

**The ; (semicolon) Separator.** The ; (semicolon) separator tells the Test Set's HP-IB command parser to back up *one* level of command hierarchy and accept the next command at the same level as the previous command. The following examples illustrate proper use of the semicolon separator:

### Example #1

```
OUTPUT 714;"RFG:AMPL -66 DBM;FREQ 500 MHZ;AMPL:STAT ON"
```

This OUTPUT statement sets the RF generator's amplitude, frequency, and output state.

### Example #2

```
OUTPUT 714;"RFG:MOD:EXT:DEST 'FM (/Vpk)';FM 12.5 KHZ;FM:STAT ON"
```

This OUTPUT statement configures the RF generator to accept external modulation from the rear-panel input, sets the amount of deviation, and turns FM on.

### Example #3

```
OUTPUT 714;"ENC:AMPS:SAT:FM 2.35 KHZ;FREQ 5.970 KHZ"
```

This OUTPUT statement sets the AMPS SAT tone's frequency and deviation.

The semicolon separator tells the Test Set's HP-IB command parser to back up *only one* level of command hierarchy. The following OUTPUT statement illustrates *improper* use of the semicolon separator.

### Example

```
OUTPUT 714;"RFG:MOD:EXT:DEST 'FM (/Vpk)';AOUT 'DC' "
```

Trying to execute this OUTPUT statement would cause HP-IB Error:-113 Undefined header. This is because the AOUT command is two levels higher than the DEST 'FM (/Vpk)' command. See the "RFGenerator Subsystem" in the *HP-IB Syntax Reference Guide* for the command hierarchy.

**The ;: (semicolon-colon) Separator..** The ;: (semicolon-colon) separator tells the Test Set's HP-IB command parser that the next command is at the top level of the command hierarchy. This allows commands from different instruments to be output on one command line. The following example illustrates proper use of the semicolon-colon separator:

**Example**

```
OUTPUT 714;"RFAN:FREQ 850 MHZ;:AFAN:INP 'FM DEMOD' "
```

This OUTPUT statement sets the RF Analyzer's tune frequency to 850 MHz, and then sets the AF Analyzer's input to FM Demod.

**Compound Commands for Combining ENTER Statements**

To reduce the number of ENTER statements used to read measured values within one screen, string together multiple measure commands within one OUTPUT statement followed by an ENTER statement with the appropriate number of variables to hold the measured values. The following example illustrates this technique.

**Example**

```
OUTPUT 714;"MEAS:RFR:POW?;FREQ:ABS?"  
ENTER 714;Power,Freq_abs
```

This OUTPUT statement requests an RF power and an absolute RF frequency measurement. The ENTER statement then reads both values into program variables.

## Screen Display Time

Each time the screen being displayed on the Test Set (active screen) is changed, it takes approximately 250 ms to access and draw the new screen. Additionally, each time a field on the active screen is changed it takes a finite amount of time to update the field. This update time is depends on the length and type of field.

When the Test Set is operated in the External Automatic Control mode it is possible to program it to only display a special “remote screen.” When the Test Set is in this mode, only the remote screen is displayed, regardless of the screen changes requested by the control program running on the external controller. The remote screen mode has no affect on the operation of the Test Set; all measurement modes, commands, and so forth, still operate normally. The only effect is that the active screen is never changed. This saves approximately 250 ms for every :DISPlay command in the control program and some finite amount of time for every field update.

When the remote screen is being displayed, the Test Set’s display is in the “locked” state. When the control program on the external controller unlocks the display, the screen is returned to the last remote screen requested. The \*RST Common Command will place the Test Set’s display screen in the “unlocked” state. Pressing the LOCAL key causes a locked Test Set display session to end and causes the Test Set’s display screen to return to the unlocked state.

**To Lock the Test Set’s Display Screen.** Use the :SPECial:DISPlay 'LOCKED'|'UNLOCKED' commands to lock and unlock the Test Set’s display screen. 'LOCKED' causes the display to go to the remote screen and ignore screen changes and other display updates thus saving time. 'UNLOCKED' causes the display to return to the last screen requested by the remoter user. Further screen changes and display updates take place as normal.

### Syntax

```
:SPECial:DISPlay 'LOCKED'  
:SPECial:DISPlay 'UNLOCKED'
```

### Example

```
OUTPUT 714: "SPEC:DISP 'LOCKED'
```

This locks the Test Set’s display screen.



**To Query the Lock/Unlock State of the Test Set's Display Screen.** Use the :SPECial:DISPlay? commands to query the lock/unlock state of the Test Set display screen.

#### Syntax

```
:SPECial:DISPlay?
```

#### Example

```
OUTPUT 714;"SPEC:DISP?"  
ENTER 714;Lock_unlock$
```

This queries the lock/unlock state of the Test Set's display screen.

---

#### NOTE

Locking and unlocking the Test Set's display screen is an External Automatic Control mode, HP-IB only function and cannot be done through the Test Set's front panel.

SPECial:DISPlay 'LOCKED' | 'UNLOCKED' must not be invoked from the Test Set's built-in IBASIC Controller. Executing these commands from an IBASIC program can produce unexpected results and is not supported.

---

## Status Reporting

This section describes the status reporting structure used in the Test Set. The structure is based on the IEEE 488.1-1987 and 488.2-1987 Standards and the Standard Commands for Programmable Instruments (SCPI) Version 1994.0.

### Status Reporting Structure Overview

Figure 6-1 on page 123 shows an overview of the status reporting structure used in the Test Set. The status reporting structure is used to communicate the Test Set's current status information to the application program. The term *status information* encompasses a variety of conditions which can occur in a Test Set, such as, has a measurement been completed, has an internal hardware failure occurred, has a command error occurred, has data available, and so forth. Many such conditions can exist in the Test Set. Like conditions are grouped together and maintained in Status Register Groups. Information in each register group is summarized into a Summary Message Bit. Summary Message Bits always track the current status of the associated register group. All of the Summary Message Bits are, in turn, summarized into the Status Byte Register.

Therefore, by monitoring the bits in the Status Byte Register the application program can determine if a condition has occurred which needs attention, which register to interrogate to determine what condition(s) have occurred, and what action to take in response to the condition.

---

NOTE

A Status Register Group Summary Message Bit may be summarized indirectly to the Status Byte Register through a Status Register Group which is summarized directly into the Status Byte Register.

Bits in the Status Byte Register can also be used to initiate a Service Request message (SRQ) by enabling the associated bit in the Service Request Enable Register. When an enabled condition exists, the Test Set sends the Service Request message (SRQ) on the HP-IB bus and reports that it has requested service by setting the Request Service (RQS) bit in the Status Byte Register to the TRUE, logic 1, state. The Service Request message (SRQ) capability of the HP-IB bus is used to automatically signal the Active Controller that the Test Set needs attention. The application program can then interrogate the Test Set and determine what caused it to request service. Refer to “[HP-IB Service Requests](#)” on page 168 for information on setting up, enabling and servicing SRQ generated interrupts.

**Figure 6-1** Status Reporting Structure Overview

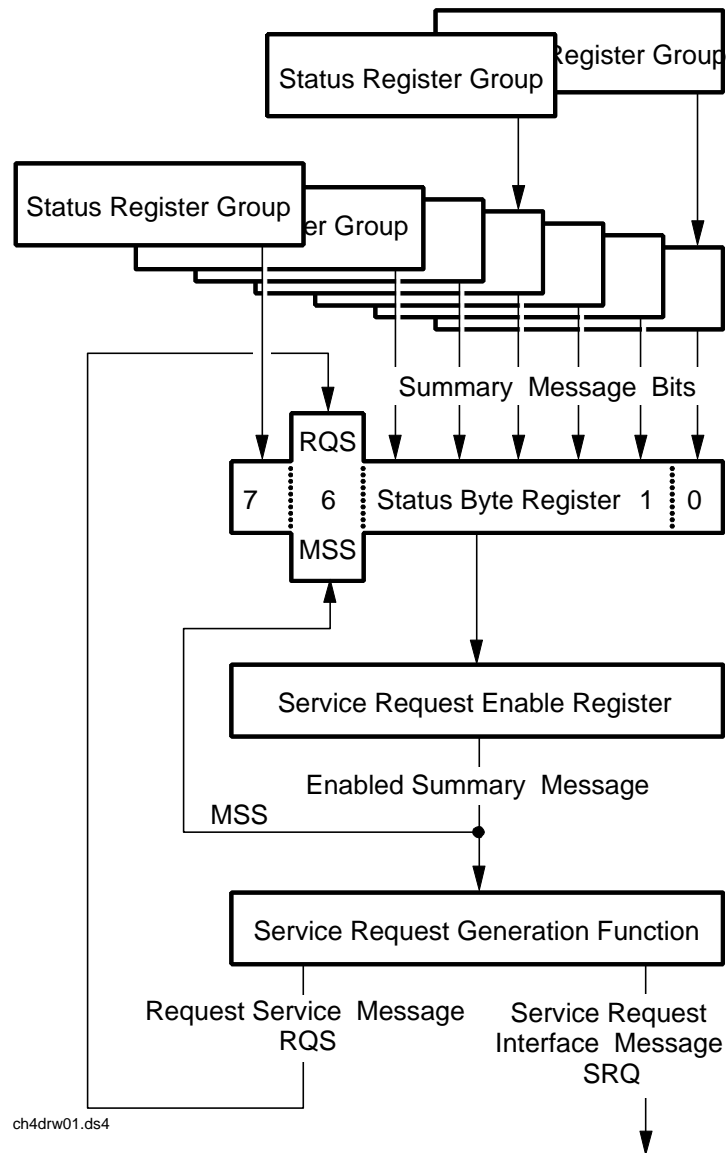

## Status Byte Register

The Status Byte Register is an 8-bit register that is used to summarize the Summary Messages from all the register groups in the Test Set, and the Request Service (RQS) or Master Summary Status (MSS) messages. The contents of the Status Byte Register, referred to as the *status byte*, can be read by the Active Controller to determine the condition of each of the register groups. The Summary Message from each register group is assigned to a specific bit position in the Status Byte Register as shown in Figure 6-2. If the Summary Message from a particular register group is TRUE, logic 1, its assigned bit in the Status Byte Register will also be TRUE. If the Summary Bit from a particular register group is FALSE, logic 0, its assigned bit in the Status Byte Register will also be FALSE.

**NOTE** A Status Register Group Summary Message Bit may be summarized indirectly to the Status Byte Register through a Status Register Group which is summarized directly into the Status Byte Register.

**Figure 6-2 Status Byte Register**

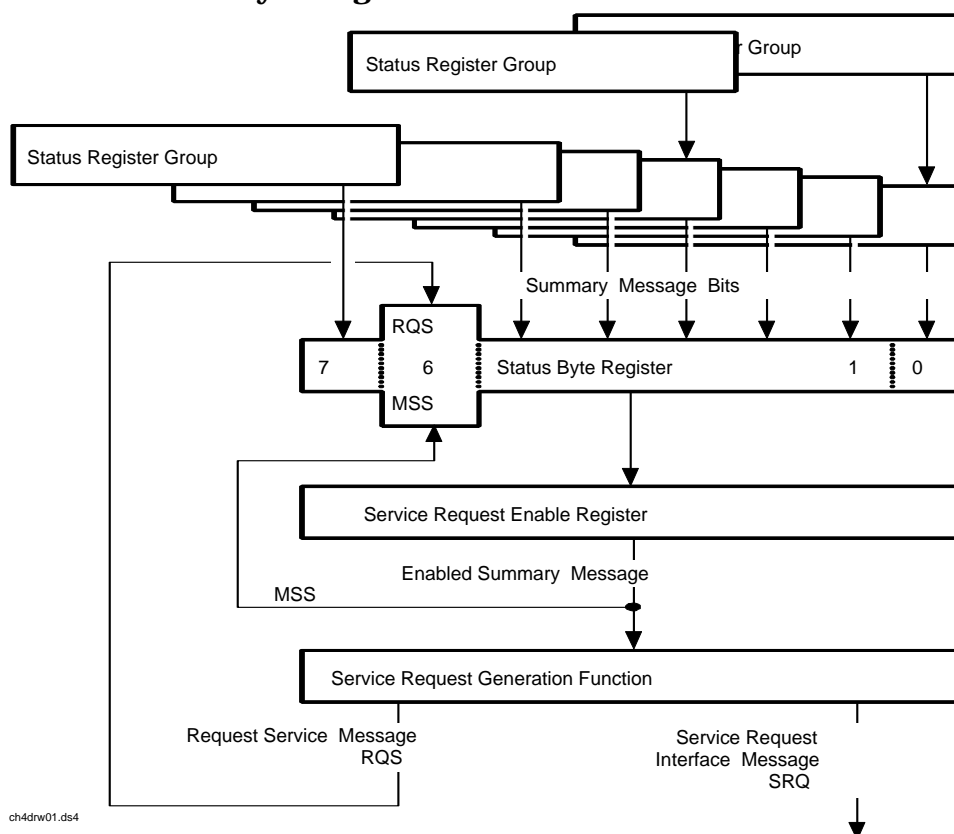

Table 6-1 on page 125 details the Status Byte Register bit assignments and their associated meaning.

**Table 6-1 Status Byte Register Bit Assignments**

Bit Number	Binary Weighting	Condition	Comment
7	128	Operation Status Register Group Summary Message	1= one or more of the enabled events have occurred since the last reading or clearing of the Event Register
6	64	Request Service (RQS) when read by serial poll OR Master Summary Status message when read by *STB? command	1= Test Set has requested service OR 1= one or more of the enabled service request conditions is true
5	32	Standard Event Status Bit (ESB) Summary Message	1= one or more of the enabled events have occurred since the last reading or clearing of the Event Register
4	16	Output Queue Message Available (MAV) Summary Message	1= information is available in the Output Queue
3	8	Questionable Data/Signal Register Group Summary Message	1= one or more of the enabled events have occurred since the last reading or clearing of the Event Register
2	4	Unused in Test Set	
1	2	Hardware #2 Status Register Group Summary Message	1 = one or more of the enabled events have occurred since the last reading or clearing of the Event Register
0	1	Hardware #1 Status Register Group Summary Message	1 = one or more of the enabled events have occurred since the last reading or clearing of the Event Register

The Status Byte Register is unique in that bit 6 can take on two different meanings. The contents of the Status Byte Register can be read two ways: by using a serial poll, or by using the \*STB? Common Command. Both methods return the status byte message, bits 0-5, and bit 7, as defined in [Table 6-1](#). The value sent for bit 6 is, however, dependent upon the method used.

### Reading with a Serial Poll

The contents of the Status Byte Register can be read by a serial poll from the Active Controller in response to some device on the bus sending the Service Request (SRQ) message. When read with a serial poll, bit 6 in the Status Byte Register represents the Request Service (RQS) condition. Bit 6 is TRUE, logic 1, if the Test Set is sending the Service Request (SRQ) message and FALSE, logic 0, if it is not. Bits 0-5 and bit 7 are defined as shown in [Table 6-1 on page 125](#). When read by a serial poll the RQS bit is cleared (set to 0) so that the RQS message will be FALSE if the Test Set is polled again before a new reason for requesting service has occurred. Bits 0-5 and bit 7 are unaffected by a serial poll.

### Reading with the \*STB? Common Command

The contents of the Status Byte Register can be read by the application program using the \*STB? Common Command. When read with the \*STB? Common Command, bit 6 represents the Master Summary Status (MSS) message. The MSS message is the inclusive OR of the bitwise combination (excluding bit 6) of the Status Byte Register and the Service Request Enable Register. For a discussion of Summary Messages, see “[Status Register Structure Overview](#)” on page 128. Bit 6 is TRUE, logic 1, if the Test Set has at least one reason for requesting service and FALSE, logic 0, if it does not. Bits 0-5 and bit 7 are defined as shown in [Table 6-1 on page 125](#). When read by the \*STB? Common Command, bits 0-5, bit 6, and bit 7 are unaffected.

The \*STB? Status Byte Query allows the programmer to determine the current contents (bit pattern) of the Status Byte Register and the Master Summary Status (MSS) message as a single element. The Test Set responds to the \*STB? query by placing the binary-weighted decimal value of the Status Byte Register and the MSS message into the Output Queue. The response represents the sum of the binary-weighted values of the Status Byte Register’s bits 0-5 and 7 (weights 1,2,4,8,16,32 and 128 respectively) and the MSS summary message (weight 64). Thus, the response to \*STB?, when considered as a binary value, is identical to the response to a serial poll except that the MSS message of 1 indicates that the Test Set has at least one reason for requesting service (Refer to the IEEE 488.2-1987 Standard for a complete description of the MSS message). The decimal value of the bit pattern will be a positive integer in the range of 0 to 255. The response data is obtained by reading the Output Queue into a numeric variable, integer or real.

## Example BASIC program to read Status Byte with \*STB command

### Example

```
10 INTEGER Stat_byte_reg,Stat_byte,Mstr_sum_msg
20 OUTPUT 714;"*STB?"
30 ENTER 714;Stat_byte_reg
40 Stat_byte=BINAND(Stat_byte_reg,191) !mask out the MSS bit
50 PRINT Stat_byte
60 Mstr_sum_msg=BINAND(Stat_byte_reg,64) !mask out the Stat Byte
70 PRINT Mstr_sum_msg
80 END
```

### Example

```
32
0
```

## Writing the Status Byte Register

The Status Byte Register is a read-only register and is altered only when the state of the Summary Messages from the overlaying data structures are altered.

## Clearing the Status Byte Register

The \*CLS Common Command clears all Event Registers and Queues so that their corresponding Summary Messages are cleared. The Output Queue and its MAV Summary Message are an exception and are unaffected by the \*CLS Common Command.

## Status Register Structure Overview

The structure of the register groups used in the Test Set is based upon the status data structures outlined in the IEEE 488 and SCPI 1994.0 Standards. There are two types of status data structures used in the Test Set: status registers and status queues. The general models, components, and operation of each type of status data structure are explained in the following sections.

**Figure 6-3** Status Data Structure - Register Model

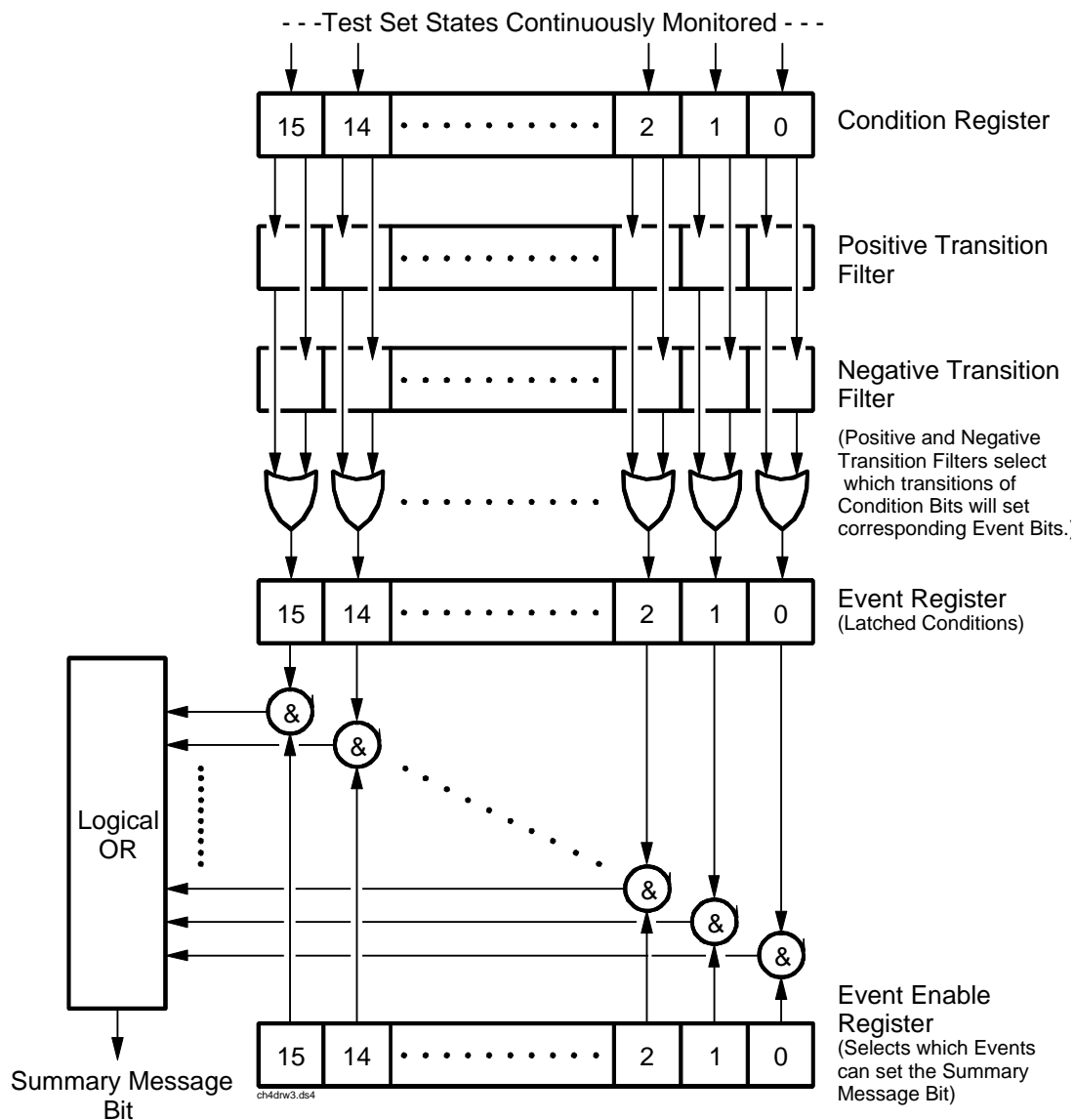



## Status Register Model

This section explains how the status registers are structured in the Test Set. The generalized status register model shown in [Figure 6-3 on page 139](#) is the basis upon which all the status registers in the Test Set are built. The model consists of a Condition Register, Transition Filters, an Event Register, an Enable Register, and a Summary Message. A set of these registers is called a Status Register Group.

**Condition Register.** A condition is a Test Set state that is either TRUE or FALSE (an HP-IB command error has occurred or an HP-IB command error has not occurred). Each bit in a Condition Register is assigned to a particular Test Set state. A Condition Register continuously monitors the hardware and firmware states assigned to it. There is no latching or buffering of any bits in a Condition Register; it is updated in real time. Condition Registers are read-only. Condition Registers in the Test Set are 16 bits long and may contain unused bits. All unused bits return a zero value when read.

**Transition Filters.** For each bit in the Condition Register, the Transition Filters determine which of two bit-state transitions will set the corresponding bit in the Event Register. Transition Filters may be set to pass positive transitions (PTR), negative transitions (NTR) or either (PTR or NTR). A positive transition means a condition bit changed from 0 to 1. A negative transition means a condition bit changed from 1 to 0.

In the Test Set, the Transition Filters are implemented as two registers: a 16-bit positive transition (PTR) register and a 16-bit negative transition (NTR) register.

- A positive transition of a bit in the Condition register will be latched in the Event Register if the corresponding bit in the positive transition filter is set to 1. A positive transition of a bit in the Condition register will *not* be latched in the Event Register if the corresponding bit in the positive transition filter is set to 0.
- A negative transition of a bit in the Condition register will be latched in the Event Register if the corresponding bit in the negative transition filter is set to 1. A negative transition of a bit in the Condition register will *not* be latched in the Event Register if the corresponding bit in the negative transition filter is set to 0.

Either transition (PTR or NTR) of a bit in the Condition Register will be latched in the Event Register if the corresponding bit in both transition filters is set to 1. No transitions (PTR or NTR) of a bit in the Condition Register will be latched in the Event Register if the corresponding bit in both transition filters is set to 0.

Transition Filters are read-write. Transition Filters are unaffected by a \*CLS (clear status) command or queries. The Transitions Filters are set to pass positive transitions (PTR) at power on and after receiving the \*RST (reset) command (all 16 bits of the PTR register set to 1 and all 16 bits of the NTR register set to 0).

**Event Register.** The Event Register captures bit-state transitions in the Condition Register as defined by the Transition Filters. Each bit in the Event Register corresponds to a bit in the Condition Register, or if there is no Condition Register/Transition Filter combination, each bit corresponds to a specific condition in the Test Set. Bits in the Event Register are latched, and, once set, they remain set until cleared by a query of the Event Register or a \*CLS (clear status) command. This guarantees that the application can't miss a bit-state transition in the Condition Register. There is no buffering; so while an event bit is set, subsequent transitions in the Condition Register corresponding to that bit are ignored. Event Registers are read-only. Event Registers in the Test Set are either 8 or 16 bits long and may contain unused bits. All unused bits return a zero value when read.

**Event Enable Register.** The Event Enable Register defines which bits in the Event Register will be used to generate the Summary Message. Each bit in the Enable Register has a corresponding bit in the Event Register. The Test Set logically ANDs corresponding bits in the Event and Enable registers and then performs an inclusive OR on all the resulting bits to generate the Summary Message. By using the enable bits the application program can direct the Test Set to set the Summary Message to the 1 or TRUE state for a single event or an inclusive OR of any group of events. Enable Registers are read-write. Enable Registers in the Test Set are either 8 or 16 bits long and may contain unused bits which correspond to unused bits in the associated Event Register. All unused bits return a zero value when read and are ignored when written to. Enable Registers are unaffected by a \*CLS (clear status) command or queries.

**Summary Message Bit.** The Summary Message is a single-bit message which indicates whether or not one or more of the enabled events have occurred since the last reading or clearing of the Event Register. The Test Set logically ANDs corresponding bits in the Event and Enable registers and then performs an inclusive OR on all the resulting bits to generate the Summary Message. By use of the enable bits, the application program can direct the Test Set to set the Summary Message to the 1, or TRUE, state for a single event or an inclusive OR of any group of events. The Summary Message is TRUE when an enabled event in the Event Register is set TRUE. Conversely, the Summary Message is FALSE when no enabled events are TRUE. Summary Messages are always seen as bits in another register.

### **Status Reporting Structure Operation.**

In general the status reporting structure described on the previous pages is used as follows:

- Determine which conditions, as defined by their bit positions in the Condition Register, should cause the Summary Message to be set TRUE if they occur.

For example, Condition Register Bit 3 = Overpower Protection Tripped

- Determine the polarity of the bit-state transition which will indicate the condition has occurred.

For example,

- logic 0 = Overpower Protection not tripped
  - logic 1 = Overpower Protection tripped
  - occurrence indicated by a 0 to 1 transition
  - use positive transition (PTR) filter for bit 3
- Set the Transition Filters to the correct polarity to pass the bit-state transition to the Event Register.

For example,

1. Set Positive Transition Filter bit 3 to 1, all other bits to 0.
  2. Set Negative Transition Filter bit 3 to 0, all other bits to 0.
- Set the correct bits in the Enable Register to generate the Summary Message if the condition has been latched into the Event Register.

For example,

Set bit 3 of the Enable Register to a logic 1, all other bits to 0.

- Repeat these steps for any register containing the Summary Message bit.

## Status Queue Model

This section explains how status queues are structured in the Test Set. The generalized status queue model shown in [Figure 6-4](#) is the basis upon which all the status queues in the Test Set are built. A queue is a data structure containing a sequential list of information. The queue is empty when all information has been read from the list. The associated Summary Message is TRUE, logic 1, if the queue contains some information and FALSE, logic 0, if the queue is empty. Queues can be cleared by reading all the information from the queue. Queues, except the Output Queue, can also be cleared using the \*CLS (clear status) command. A status queue can also be referred to as a Status Register Group.

**Figure 6-4** Status Data Structure - Queue Mode

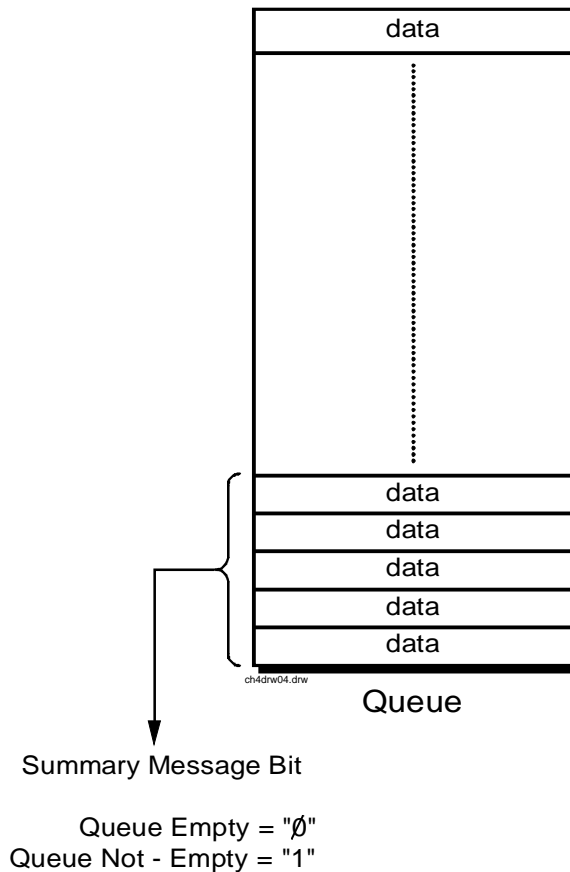

## Status Register Group Contents

Figure 6-5 shows the Status Register Groups in the Test Set. The contents of each Status Register Group is explained in the following sections.

**Figure 6-5 Test Set Status Register Groups**

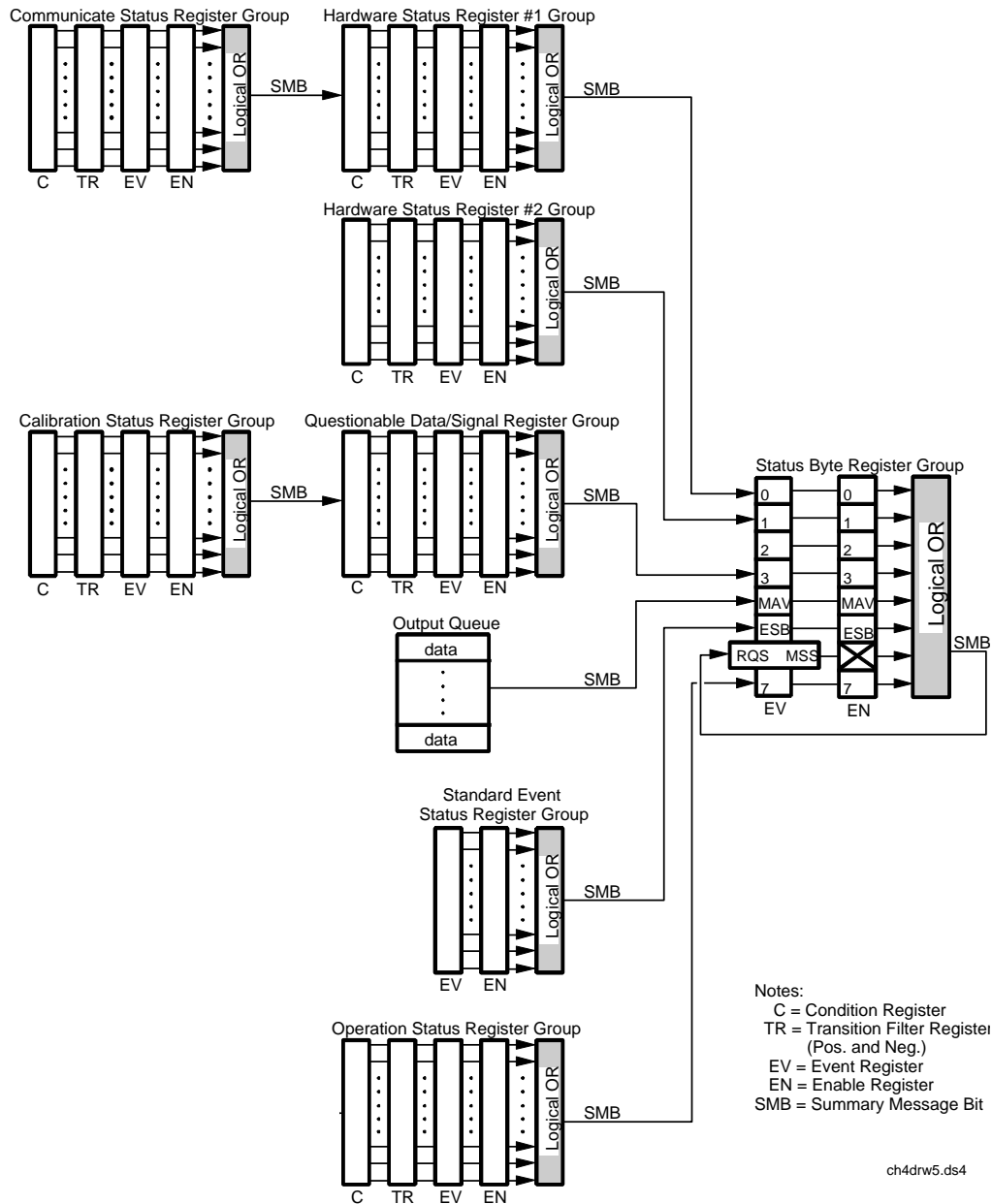

## Operation Status Register Group

The Operation Status Register Group contains information about the state of the measurement systems in the Test Set. This status group is accessed using the STATus commands. The Operation Status Register Group uses 16-bit registers and includes a Condition Register, Transition Filters, an Event Register, an Enable Register, and a Summary Message. Refer to the “[Status Register Structure Overview](#)” on page 128 for a discussion of status register operation. [Figure 6-6](#) shows the structure and STATus commands for the Operation Status Register Group.

**Figure 6-6** Operation Status Register Group

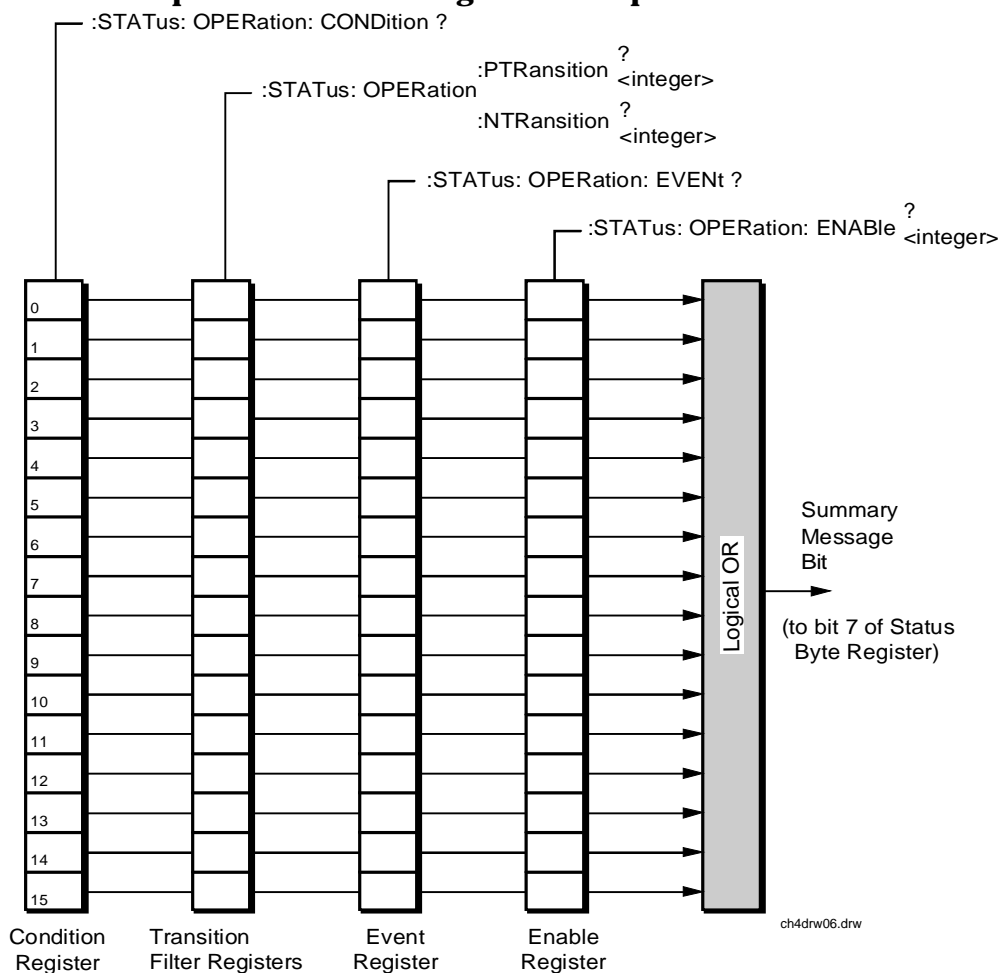

[Table 6-2 on page 135](#) shows the Operation Status Register Group Condition Register bit assignments.

**Table 6-2                    Operation Status Register Group Condition Register Bit Assignments**

<b>Bit Number</b>	<b>Binary Weighting</b>	<b>Condition</b>	<b>Comment</b>
15	32768	Not Used (Always 0)	Defined by SCPI Version 1994.0
14	16384	IBASIC Program Running	1 = an IBASIC program is running on the built-in IBASIC controller.
13	8192	Unused in the Test Set	
12	4096	Unused in the Test Set	
11	2048	Unused in the Test Set	
10	1024	Unused in the Test Set	
9	512	Status Register Group Summary Message	1 = one or more of the enabled events have occurred since the last reading or clearing of the Event Register.
8	256	Unused in the Test Set	
7	128	Unused in the Test Set	
6	64	Unused in the Test Set	
5	32	Unused in the Test Set	
4	16	Unused in the Test Set	
3	8	Unused in the Test Set	
2	4	Unused in the Test Set	
1	2	Unused in the Test Set	
0	1	Unused in the Test Set	

## Accessing the Operation Status Register Group's Registers

The following sections show the syntax and give programming examples, using the HP BASIC programming language, for the STATUS commands used to access the Operation Status Register Group's registers.

### Reading the Condition Register.

#### Syntax

```
STATUS:OPERation:CONDition?
```

#### Example

```
OUTPUT 714;"STAT:OPER:COND?"  
ENTER 714;Register_value
```

### Reading the Transition Filters.

#### Syntax

```
STATUS:OPERation:PTRansition?  
STATUS:OPERation:NTRansition?
```

#### Example

```
OUTPUT 714;"STAT:OPER:PTR?"  
ENTER 714;Register_value
```

### Writing the Transition Filters.

#### Syntax

```
STATUS:OPERation:PTRansition <integer>  
STATUS:OPERation:NTRansition <integer>
```

#### Example

```
OUTPUT 714;"STAT:OPER:PTR 256"
```

### Reading the Event Register.

#### Syntax

```
STATUS:OPERation:EVENT?
```

#### Example

```
OUTPUT 714;"STAT:OPER:EVEN?"  
ENTER 714;Register_value
```



### **Clearing the Event Register.**

The EVENT register is cleared whenever it is queried or whenever the Common Command \*CLS is sent to the Test Set.

### **Reading the Enable Register.**

#### **Syntax**

```
STATus:OPERation:ENABle?
```

#### **Example**

```
OUTPUT 714;"STAT:OPER:ENAB?"  
ENTER 714;Register_value
```

### **Writing the Enable Register.**

#### **Syntax**

```
STATus:OPERation:ENABle <integer>
```

#### **Example**

```
OUTPUT 714;"STAT:OPER:ENAB 256"
```

### **Clearing the Enable Register.**

The ENABLE register is cleared by writing to it with an integer value of zero.

## Standard Event Status Register Group

The Standard Event Status Register Group is a specific implementation of the status register model described in the Status Register Structure Overview section. The conditions monitored by the Standard Event Status Register Group are defined by the IEEE 488.2-1987 Standard. The Standard assigns specific Test Set conditions to specific bits in the Standard Event Status Register. [Table 6-3 on page 139](#) details the Standard Event Status Register bit assignments and their meanings. The Standard Event Status Register Group is accessed using IEEE 488.2 Common Commands. The Standard Event Status Register Group includes an Event Register, an Enable Register, and a Summary Bit. Refer to the “[Status Reporting Structure Overview](#)” on page 122 for a discussion of status register operation. [Figure 6-7](#) shows the structure and IEEE 488.2 Common Commands used to access the Standard Event Status Register Group.

**Figure 6-7**

**Standard Event Status Register Group**

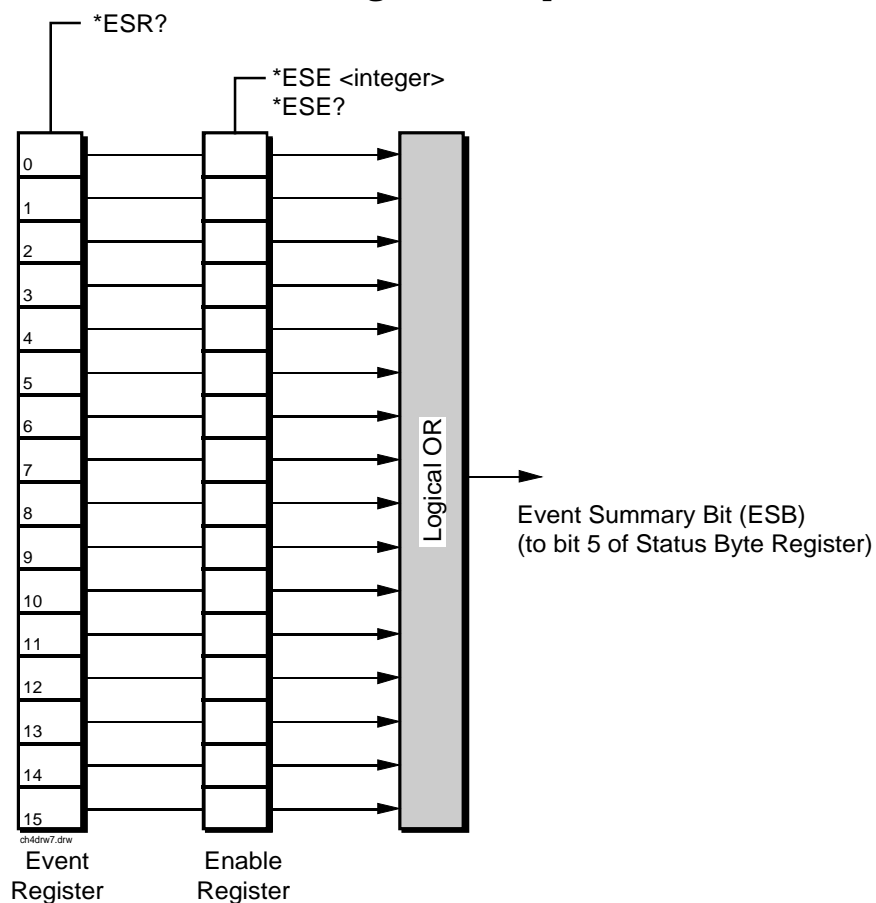

**Table 6-3 Standard Event Status Register Bit Assignments**

<b>Bit Number</b>	<b>Binary Weighting</b>	<b>Condition</b>	<b>Comment</b>
15	32879	Always 0	Reserved by IEEE 488.2
14	16384	Always 0	Reserved by IEEE 488.2
13	8192	Always 0	Reserved by IEEE 488.2
12	4096	Always 0	Reserved by IEEE 488.2
11	2048	Always 0	Reserved by IEEE 488.2
10	1024	Always 0	Reserved by IEEE 488.2
9	512	Always 0	Reserved by IEEE 488.2
8	256	Always 0	Reserved by IEEE 488.2
7	128	Power On	1 = Test Set's power supply has been turned off and then on since the last time this register was read.
6	64	User Request	Not implemented in Test Set.
5	32	Command Error	<p>1 = The Test Set detected an error while trying to process a command. The following events cause a command error:</p> <ul style="list-style-type: none"> <li>• An IEEE 488.2 syntax error. This means that the Test Set received a message that did not follow the syntax defined by the Standard.</li> <li>• A semantic error. For example, the Test Set received an incorrectly spelled command.</li> <li>• The Test Set received a Group Execute Trigger (GET) inside a program message.</li> </ul>
4	16	Execution Error	<p>1 = The Test Set detected an error while trying to execute a command. The following events cause an execution error:</p> <ul style="list-style-type: none"> <li>• A &lt;PROGRAM DATA&gt; element received in a command is outside the legal range for the Test Set or is inconsistent with the operation of the Test Set.</li> <li>• The Test Set could not execute a valid command due to some Test Set hardware/firmware condition.</li> </ul>

<b>Bit Number</b>	<b>Binary Weighting</b>	<b>Condition</b>	<b>Comment</b>
3	8	Device Dependent Error	1 = A Test Set dependent error has occurred. This means that some Test Set operation did not execute properly due to some internal condition, such as overrange. This bit indicates that the error was not a command, query, or execution error.
2	4	Query Error	1 = An error has occurred while trying to read the Test Set's Output Queue. The following events cause a query error: <ul style="list-style-type: none"> <li>• An attempt is being made to read data from the Output Queue when no data is present or pending.</li> <li>• Data in the Output Queue has been lost. An example of this would be Output Queue overflow.</li> </ul>
1	2	Request Control	1 = The Test Set is requesting permission to become the Active Controller on the HP-IB bus.
0	1	Operation Complete	1 = The Test Set has completed all selected pending operations and is ready to accept new commands. This bit is only generated in response to the *OPC IEEE 488.2 Common Command.

## Accessing the Standard Event Status Register Group's Registers

The following sections show the syntax and give programming examples (using the HP BASIC programming language) for the Common Commands used to access the Standard Event Status Register Group's registers.

### Reading the Event Register.

#### Syntax

```
*ESR?
```

#### Example

```
OUTPUT 714;"*ESR?"
```

```
ENTER 714;Register_value
```

The \*ESR? query allows the programmer to determine the current contents (bit pattern) of the Standard Event Status Register. The Test Set responds to the \*ESR? query by placing the binary-weighted decimal value of the Standard Event Status Register bit pattern into the Output Queue. The decimal value of the bit pattern will be a positive integer in the range of 0 to 255. The response data is obtained by reading the Output Queue into a numeric variable, integer or real. Reading the Standard Event Status Register clears it (sets all bits to zero).

#### Example BASIC program

```
10 INTEGER Std_evn_stat_rg
20 OUTPUT 714;"*ESR?"
30 ENTER 714;Std_evn_stat_rg
40 PRINT Std_evn_stat_rg
50 END
```

#### Example response

```
32
```

### Clearing the Event Register.

The EVENT register is cleared whenever it is queried or whenever the \*CLS Common Command is sent to the Test Set.

## Reading the Enable Register.

### Syntax

\*ESE?

### Example

```
OUTPUT 714;"*ESE?"  
ENTER 714;Register_value
```

The \*ESE? query allows the programmer to determine the current contents (bit pattern) of the Standard Event Status Enable Register. The Test Set responds to the \*ESE? query by placing the binary-weighted decimal value of the Standard Event Status Enable Register bit pattern into the Output Queue. The decimal value of the bit pattern will be a positive integer in the range of 0 to 255. The response data is obtained by reading the Output Queue into a numeric variable, integer or real.

### Example BASIC program

```
10 INTEGER Std_evn_enab_rg  
20 OUTPUT 714;"ESE?"  
30 ENTER 714;Std_evn_enab_rg  
40 PRINT Std_evn_enab_rg  
50 END
```

### Example response

36

## Writing the Enable Register.

### Syntax

\*ESE <integer>

### Example

OUTPUT 714;"\*ESE 255"

The \*ESE command sets the bit pattern (bits 0 through 7) of the Standard Event Status Enable Register. The Standard Event Status Enable Register allows the programmer to indicate the occurrence of one or more events (as defined by bits 0 through 7 of the Standard Event Status Register) in bit 5 of the Status Byte Register.

The bit pattern set by the \*ESE command is determined by selecting the desired event(s) from the Standard Event Status Register, setting the value of the bit position(s) to a logical one, setting the value of all non-selected bit positions to a logical zero, and sending the binary-weighted decimal equivalent of bits 0 through 7 after the \*ESE command. For example, if the programmer wished to have the occurrence of a Command Error (bit position 5 in the Standard Event Status Register) and the occurrence of a Query Error (bit position 2 in the Standard Event Status Register) to be reflected in bit 5 of the Status Byte Register, the binary-weighted decimal value of the bit pattern for the Standard Event Status Enable Register would be determined as follows:

**Table 6-4**

Bit Position	7	6	5	4	3	2	1	0	
Logical Value	0	0	1	0	0	1	0	0	
Binary Weighting	128	64	32	16	8	4	2	1	
Decimal Value	0	+0	+32	+0	+0	+4	+0	+0	= 36

### Example

OUTPUT 714;"\*ESE 36"

The decimal value of the bit pattern must be a positive integer in the range of 0 to 255. Sending a negative number or a number greater than 255 causes an

HP-IB Error: -222 Data out of range.

## Clearing the Enable Register.

The ENABLE register is cleared by writing to it with an integer value of zero.

## Output Queue Group

The Output Queue Group is a specific implementation of the status queue model described in “[Status Queue Model](#)” on page 132. The Output Queue queue type is defined by the IEEE 488.2-1987 Standard to be a first in, first out (FIFO) queue. The Output Queue Group includes a FIFO queue and a Message Available (MAV) Summary Message. Refer to the “[Status Reporting Structure Overview](#)” on page 122 for an overview of status queue operation. [Figure 6-8](#) shows the structure of the Output Queue Group.

**Figure 6-8**      **Output Queue Group**

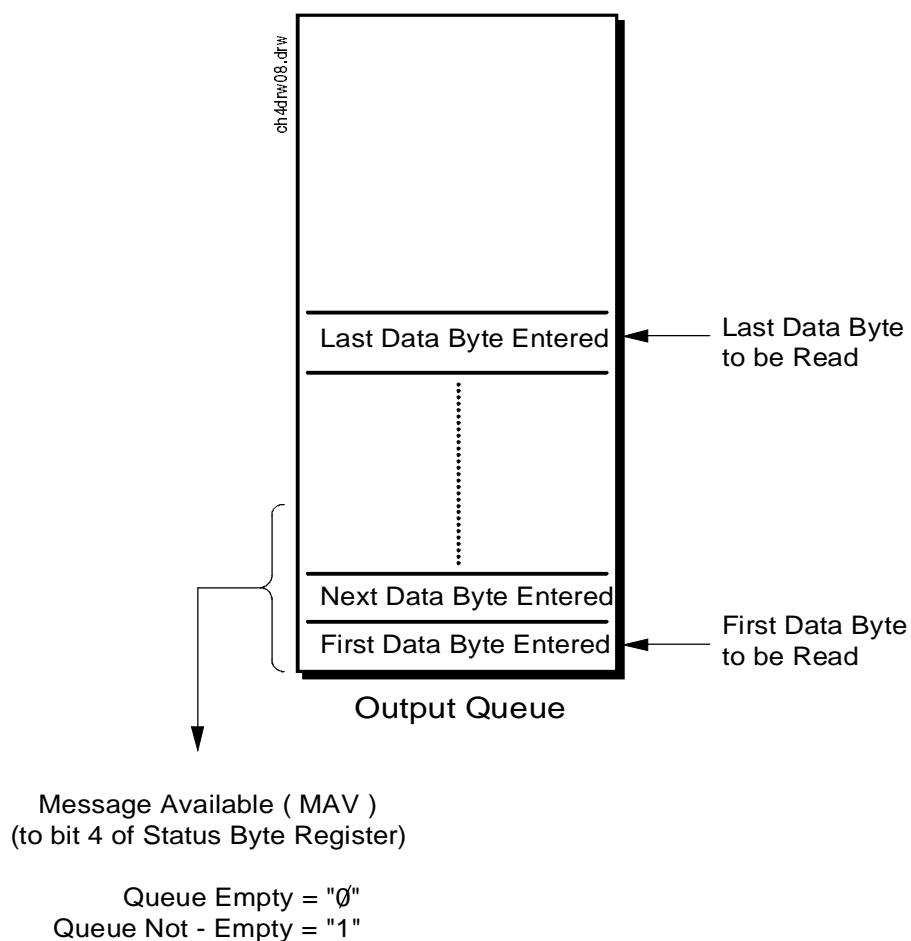



## Accessing the Output Queue

When messages are sent to the Test Set, it decodes the message to determine what commands have been sent. Depending upon the type of command, the Test Set's processor sends messages to various parts of the instrument. Many commands generate data which must be sent back to the controller. This data is buffered in the Output Queue until it is read by the controller. The availability of data is summarized in the MAV bit of the Status Byte Register. The state of the MAV message indicates whether or not the Output Queue is empty. The MAV message is TRUE, logic 1, when there is data in the Output Queue and FALSE, logic 0, when it is empty. The Output Queue is read by addressing the Test Set to TALK and then handshaking the bytes out of the Output Queue. Depending upon the type of command sent, the data may appear in the Output Queue almost immediately, or it may take several seconds (as is the case with some Signaling Decoder measurements). Care should be exercised when reading the Output Queue since the HP-IB bus will, by design, wait until the data is available before processing further bus messages.

### Reading the Output Queue.

#### Example

```
Enter 714;Output_data
```

## Error Message Queue Group

The Error Message Queue Group is an implementation of the status queue model described in “[Status Queue Model](#)” on page 132. The Error Message Queue queue type is a first-in, first-out (FIFO) queue that holds up to 20 messages. The Error Message Queue Group includes a FIFO queue but no Message Available (MAV) Summary Message. Refer to the “[Status Reporting Structure Overview](#)” on page 122 for an overview of status queue operation. [Figure 6-9](#) shows the structure of the Error Message Queue Group.

**Figure 6-9** Error Message Queue Group

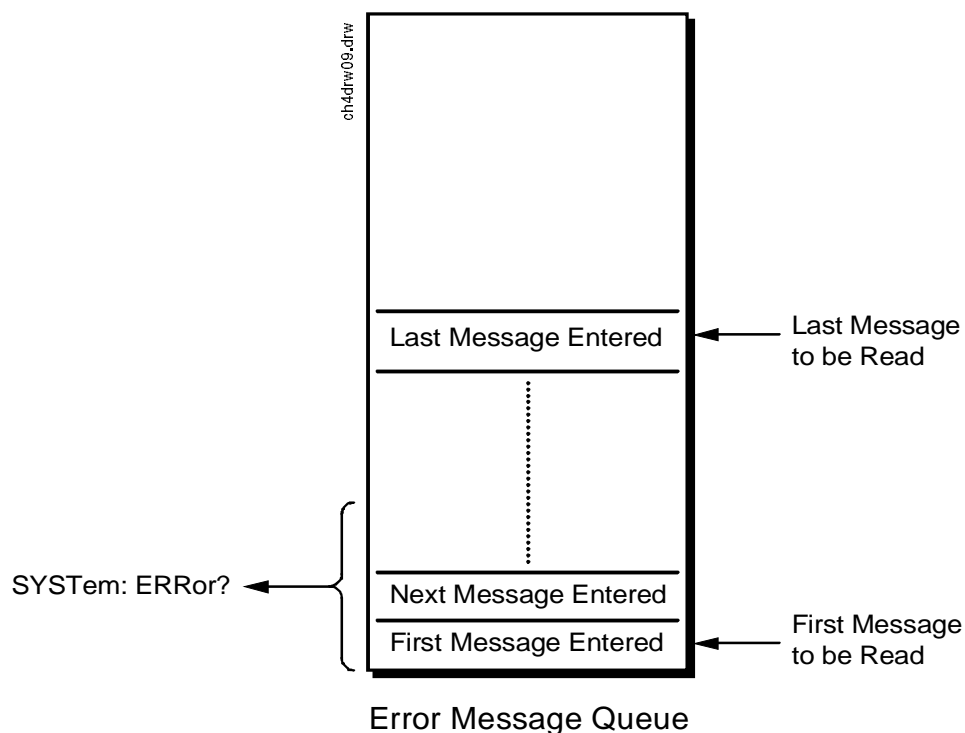

## Accessing the Error Message Queue

A message appears in the Error Message Queue any time bit 2, 3, 4, or 5 of the Standard Event Status register is asserted. Each message consists of a signed error number, followed by a comma separator, followed by an error description string in double quotes. The maximum length of the error description string is 255 characters. If more than 20 messages are in the queue and another error occurs, the last message is replaced with the message, -350, "Queue overflow". If no messages are in the queue the message, +0, "No error" is returned. Reading a message removes it from the queue. The Error Message Queue is accessed using the SYSTem command. Returned information is read into a numeric variable followed by a string variable.

### Reading the Error Message Queue.

#### Syntax

```
SYSTem:ERRor?
```

#### Example

```
OUTPUT 714;"SYST:ERR?"  
ENTER 714;Error_num,Error_msg$
```

#### Example IBASIC program

```
10 INTEGER Error_num  
20 DIM Error_msg$ [255]  
30 OUTPUT 714;"SYST:ERR?"  
40 ENTER 714;Error_num,Error_msg$  
50 PRINT Error_num;Error_msg$  
60 END
```

#### Example response

```
-113 "Undefined header"
```

## Questionable Data/Signal Register Group

The Questionable Data/Signal Register Group contains information about the quality of the Test Set's output and measurement data. This status group is accessed using the STATus commands. The Questionable Data/Signal Register Group uses 16-bit registers and includes a Condition Register, Transition Filters, an Event Register, an Enable Register, and a Summary Message. Refer to the "[Status Reporting Structure Overview](#)" on page 122 for a discussion of status register operation. [Figure 6-10](#) on page 148 shows the structure and STATus commands for the Questionable Data/Signal Register Group.

**Figure 6-10** Questionable Data/Signal Register Group

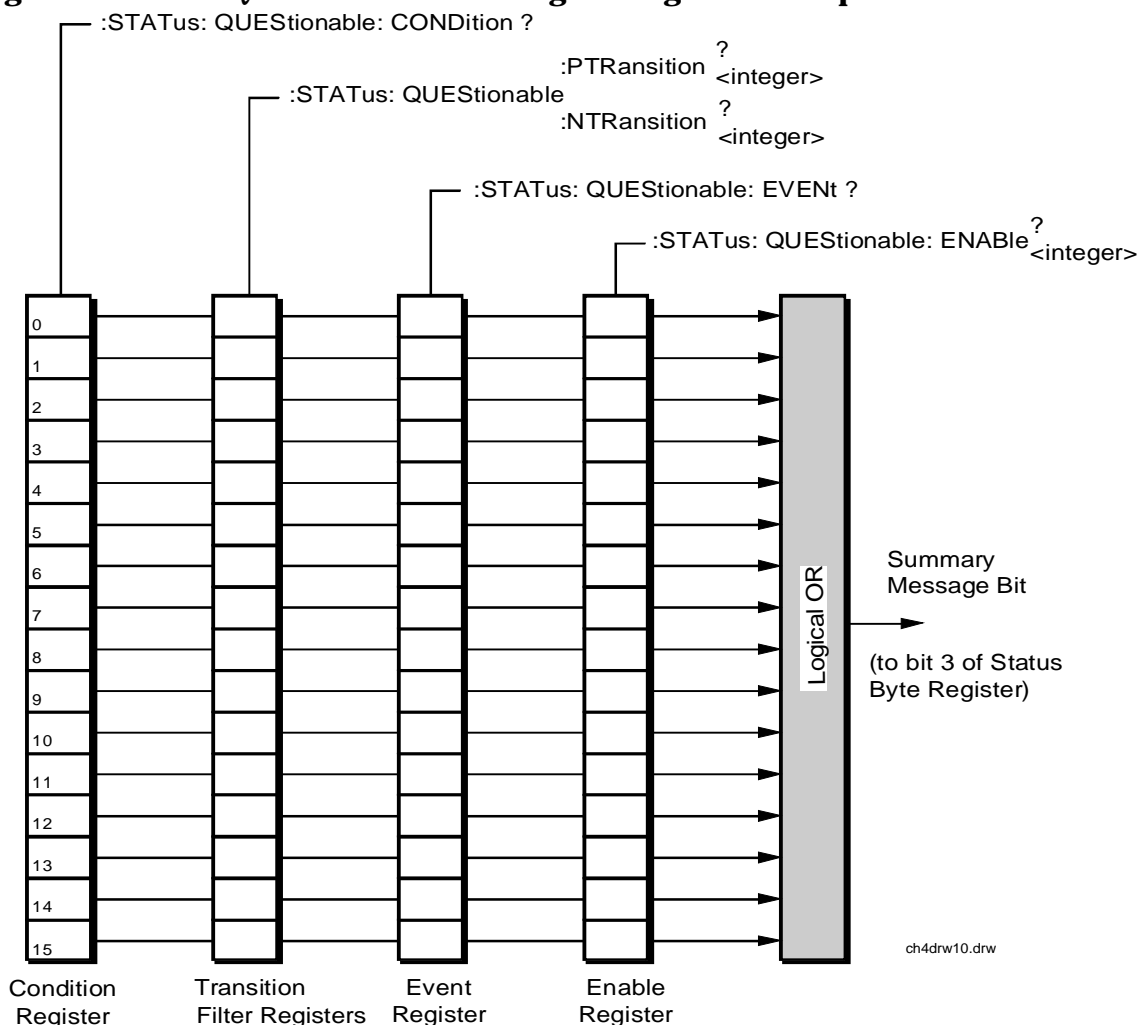

[Table 6-5](#) on page 149 shows the Questionable Data/Signal Register Group's Condition Register bit assignments.

**Table 6-5 Questionable Data/Signal Register Group, Condition Register Bit Assignments**

<b>Bit Number</b>	<b>Binary Weighting</b>	<b>Condition</b>	<b>Comment</b>
15	32768	Not Used (Always 0)	Defined by SCPI Version 1994.0
14	16384	Unused in Test Set	
13	8192	Unused in Test Set	
12	4096	Unused in Test Set	
11	2048	Unused in Test Set	
10	1024	Unused in Test Set	
9	512	Unused in Test Set	
8	256	Calibration Register Group Summary Message	1 = one or more of the enabled events have occurred since the last reading or clearing of the Event Register.
7	128	Unused in Test Set	
6	64	Unused in Test Set	
5	32	Unused in Test Set	
4	16	Unused in Test Set	
3	8	Unused in Test Set	
2	4	Unused in Test Set	
1	2	Unused in Test Set	
0	1	Unused in Test Set	

## Accessing the Questionable Data/Signal Register Group's Registers

The following sections show the syntax and give programming examples (using the HP BASIC programming language) for the STATus commands used to access the Questionable Data/Signal Register Group's registers.

### Reading the Condition Register.

#### Syntax

```
STATus:QUEStionable:CONDition?
```

#### Example

```
OUTPUT 714;"STAT:QUES:COND?"  
ENTER 714;Register_value
```

### Reading the Transition Filters.

#### Syntax

```
STATus:QUEStionable:PTRansition?  
STATus:QUEStionable:NTRansition?
```

#### Example

```
OUTPUT 714;"STAT:QUES:PTR?"  
ENTER 714;Register_value
```

### Writing the Transition Filters.

#### Syntax

```
STATus:QUEStionable:PTRansition <integer>  
STATus:QUEStionable:NTRansition <integer>
```

#### Example

```
OUTPUT 714;"STAT:QUES:PTR 256"
```

## Reading the Event Register.

### Syntax

```
STATus:QUEStionable:EVENT?
```

### Example

```
OUTPUT 714;"STAT:QUES:EVEN?"  
ENTER 714;Register_value
```

## Clearing the Event Register.

The EVENT register is cleared whenever it is queried or whenever the Common Command \*CLS is sent to the Test Set.

## Reading the Enable Register.

### Syntax

```
STATus:QUEStionable:ENABle?
```

### Example

```
OUTPUT 714;"STAT:QUES:ENAB?"  
ENTER 714;Register_value
```

## Writing the Enable Register.

### Syntax

```
STATus:QUEStionable:ENABle <integer>
```

### Example

```
OUTPUT 714;"STAT:QUES:ENAB 256"
```

## Clearing the Enable Register.

The ENABLE register is cleared by writing to it with an integer value of zero.

## Calibration Status Register Group

The Calibration Status Register Group contains information about the Test Set's hardware. This status group is accessed using the STATUS commands. The Calibration Status Register Group uses 16-bit registers and includes a Condition Register, Transition Filters, an Event Register, an Enable Register, and a Summary Message. Refer to the "Status Reporting Structure Overview" on page 122 for a discussion of status register operation. Figure 6-11 shows the structure and STATUS commands for the Calibration Status Register Group.

**Figure 6-11 Calibration Status Register Group**

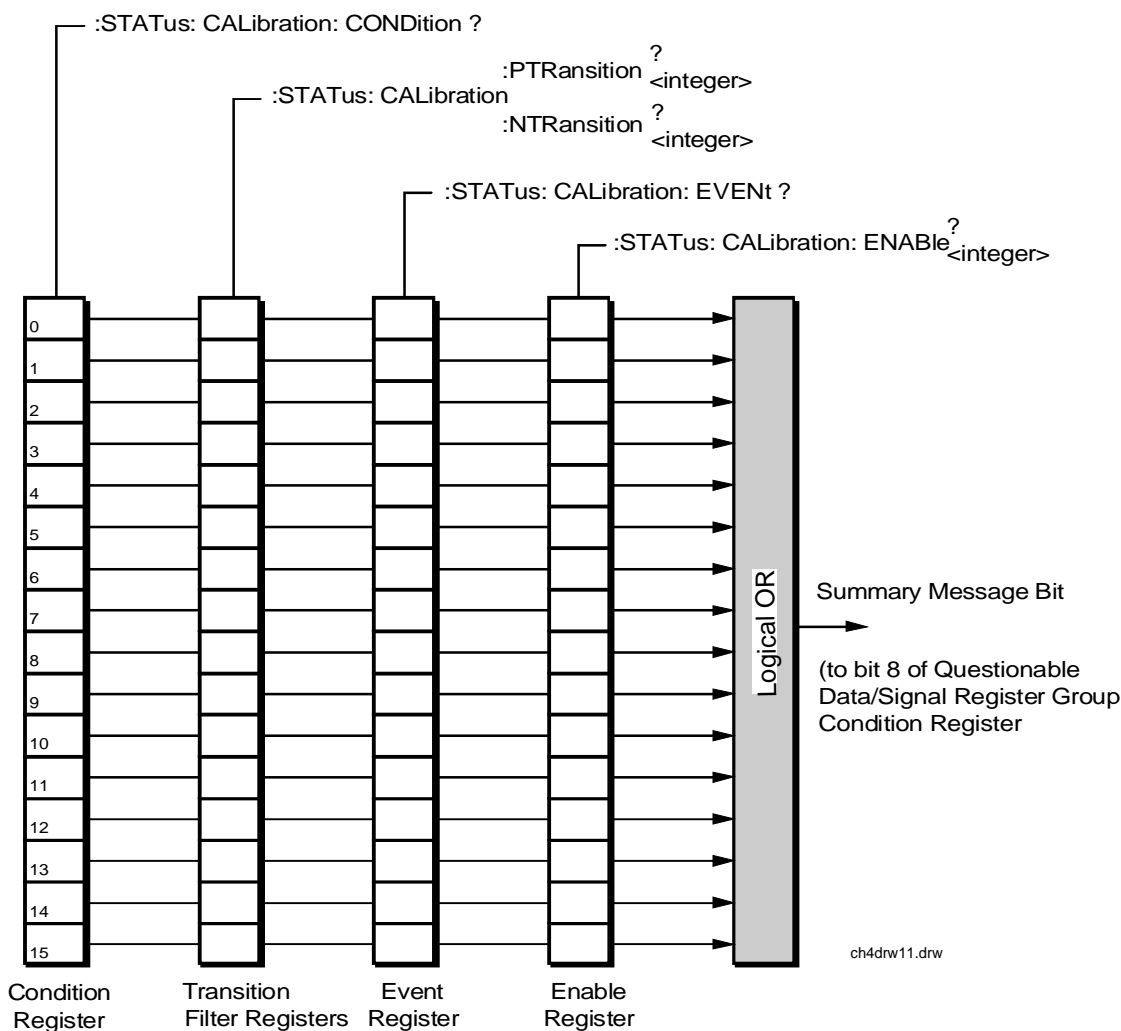

Table 6-6 on page 153 details the Calibration Status Register Group's Condition Register bit assignments.



**Table 6-6 Calibration Status Register Group, Condition Register Bit Assignments**

<b>Bit Number</b>	<b>Binary Weighting</b>	<b>Condition</b>	<b>Comment</b>
15	32768	Not Used (Always 0)	Defined by SCPI Version 1994.0
14	16384	Unused in Test Set	
13	8192	Unused in Test Set	
12	4096	Unused in Test Set	
11	2048	Unused in Test Set	
10	1024	Unused in Test Set	
9	512	Unused in Test Set	
8	256	Unused in Test Set	
7	128	Unused in Test Set	
6	64	Unused in Test Set	
5	32	Unused in Test Set	
4	16	TX Power Auto-Zero Failed	
3	8	Voltmeter Self-Calibration Failed	
2	4	Counter Self-Calibration Failed	
1	2	Sampler Self-Calibration Failed	
0	1	Spectrum Analyzer Self-Calibration Failed	

## Accessing the Calibration Status Register Group's Registers

The following sections show the syntax and give programming examples (using the HP BASIC programming language) for the STATUS commands used to access the Calibration Status Register Group's registers.

### Reading the Condition Register.

#### Syntax

```
STATUS:CALibration:CONDition?
```

#### Example

```
OUTPUT 714;"STAT:CAL:COND?"  
ENTER 714;Register_value
```

### Reading the Transition Filters.

#### Syntax

```
STATUS:CALibration:PTRansition?  
STATUS:CALibration:NTRansition?
```

#### Example

```
OUTPUT 714;"STAT:CAL:PTR?"  
ENTER 714;Register_value
```

### Writing the Transition Filters.

#### Syntax

```
STATUS:CALibration:PTRansition <integer>  
STATUS:CALibration:NTRansition <integer>
```

#### Example

```
OUTPUT 714;"STAT:CAL:PTR 256"
```

### Reading the Event Register.

#### Syntax

```
STATUS:CALibration:EVENT?
```

#### Example

```
OUTPUT 714;"STAT:CAL:EVENT?"  
ENTER 714;Register_value
```

### **Clearing the Event Register.**

The EVENT register is cleared whenever it is queried or whenever the Common Command \*CLS is sent to the Test Set.

### **Reading the Enable Register.**

#### **Syntax**

```
STATus:CALibration:ENABle?
```

#### **Example**

```
OUTPUT 714;"STAT:CAL:ENAB?"  
ENTER 714;Register_value
```

### **Writing the Enable Register.**

#### **Syntax**

```
STATus:CALibration:ENABle <integer>
```

#### **Example**

```
OUTPUT 714;"STAT:CAL:ENAB 256"
```

### **Clearing the Enable Register.**

The ENABLE register is cleared by writing to it with an integer value of zero.

## Hardware Status Register #2 Group

The Hardware Status Register #2 Group contains information about the Test Set's hardware. This status group is accessed using the STATus commands. The Hardware Status Register #2 Group uses 16-bit registers and includes a Condition Register, Transition Filters, an Event Register, an Enable Register, and a Summary Message. Refer to the "Status Reporting Structure Overview" on page 122 for a discussion of status register operation. Figure 6-12 shows the structure and STATus commands for the Hardware Status Register #2 Group.

**Figure 6-12 Hardware Status Register #2 Group**

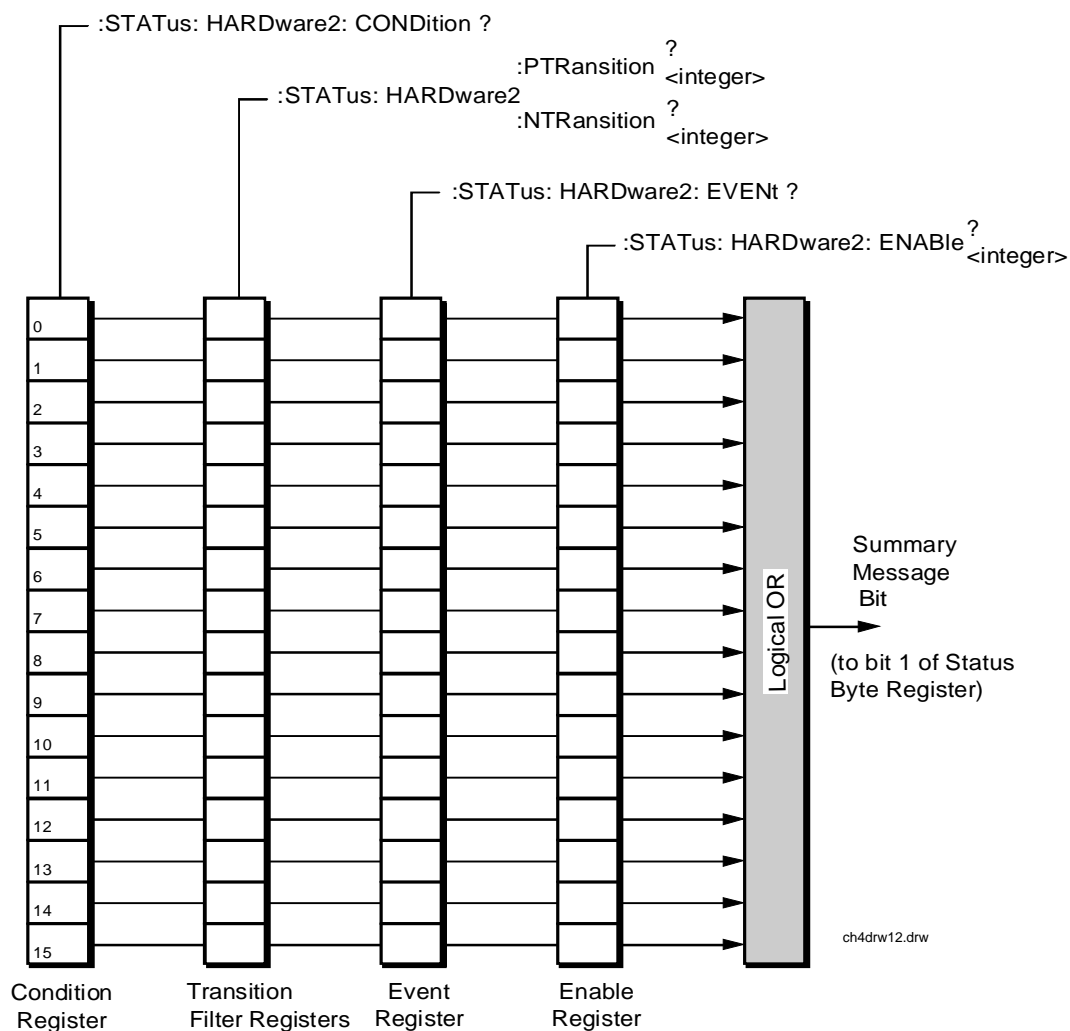

Table 6-7 on page 157 shows the Hardware Status Register Group #2's Condition Register bit assignments.

**Table 6-7 Hardware Status Register Group #2, Condition Register Bit Assignments**

Bit Number	Binary Weighting	Condition	Comment
15	32768	Not Used (Always 0)	Defined by SCPI Version 1994.0
14	16384	Unused in Test Set	
13	8192	Unused in Test Set	
12	4096	Unused in Test Set	
11	2048	Inconsistent ACP Channel Bandwidth and Resolution Bandwidth	
10	1024	ACP Channel Bandwidth or Channel Offset too wide	
9	512	AFGen1 Frequency Exceeds Variable Frequency Notch Filter Range	
8	256	Requested Audio Voltage Too Large for AFGen2	
7	128	Requested FM Deviation Too Large for RF Generator Frequency	
6	64	Requested Simultaneous AM and FM Modulation	Simultaneous AM and FM modulation is not allowed.
5	32	Audio Input Level Auto Ranging Error	
4	16	----	Not assigned.
3	8	----	Not assigned.
2	4	RF Gen/RF Anl/RF Offset Frequency Combination Not Possible	(RF Gen Tune Freq) - (RF Anal Tune Freq) not equal to (RF Offset Freq)
1	2	RF Generator Amplitude Level Too High for Selected Output Port	
0	1	Spectrum Analyzer Reference Level Too High/Low For Selected Input Port	

## Accessing the Hardware Status Register #2 Group's Registers

The following sections show the syntax and give programming examples (using the HP BASIC programming language) for the STATus commands used to access the Hardware Status Register #2 Group's registers.

### Reading the Condition Register.

#### Syntax

```
STATus:HARDware2:CONDition?
```

#### Example

```
OUTPUT 714;"STAT:HARD2:COND?"  
ENTER 714;Register_value
```

### Reading the Transition Filters.

#### Syntax

```
STATus:HARDware2:PTRansition?  
STATus:HARDware2:NTRansition?
```

#### Example

```
OUTPUT 714;"STAT:HARD2:PTR?"  
ENTER 714;Register_value
```

## Writing the Transition Filters.

### Syntax

```
STATus:Hardware2:PTRansition <integer>
STATus:Hardware2:NTRansition <integer>
```

### Example

```
OUTPUT 714;"STAT:HARD2:PTR 256"
```

## Reading the Event Register.

### Syntax

```
STATus:Hardware2:EVENT?
```

### Example

```
OUTPUT 714;"STAT:HARD2:EVEN?"
ENTER 714;Register_value
```

## Clearing the Event Register.

The EVENT register is cleared whenever it is queried or whenever the Common Command \*CLS is sent to the Test Set.

## Reading the Enable Register.

### Syntax

```
STATus:Hardware2:ENABle?
```

### Example

```
OUTPUT 714;"STAT:HARD2:ENAB?"
ENTER 714;Register_value
```

## Writing the Enable Register.

### Syntax

```
STATus:Hardware2:ENABle <integer>
```

### Example

```
OUTPUT 714;"STAT:HARD2:ENAB 256"
```

## Clearing the Enable Register.

The ENABLE register is cleared by writing to it with an integer value of zero.

## Hardware Status Register #1 Group

The Hardware Status Register #1 Group contains information about the Test Set's hardware. This status group is accessed using the STATus commands. The Hardware Status Register #1 Group uses 16-bit registers and includes a Condition Register, Transition Filters, an Event Register, an Enable Register, and a Summary Message. Refer to the "Status Reporting Structure Overview" on page 122 section for a discussion of status register operation. Figure 6-13 shows the structure and STATus commands for the Hardware Status Register #1 Group.

**Figure 6-13** Hardware Status Register #1 Group

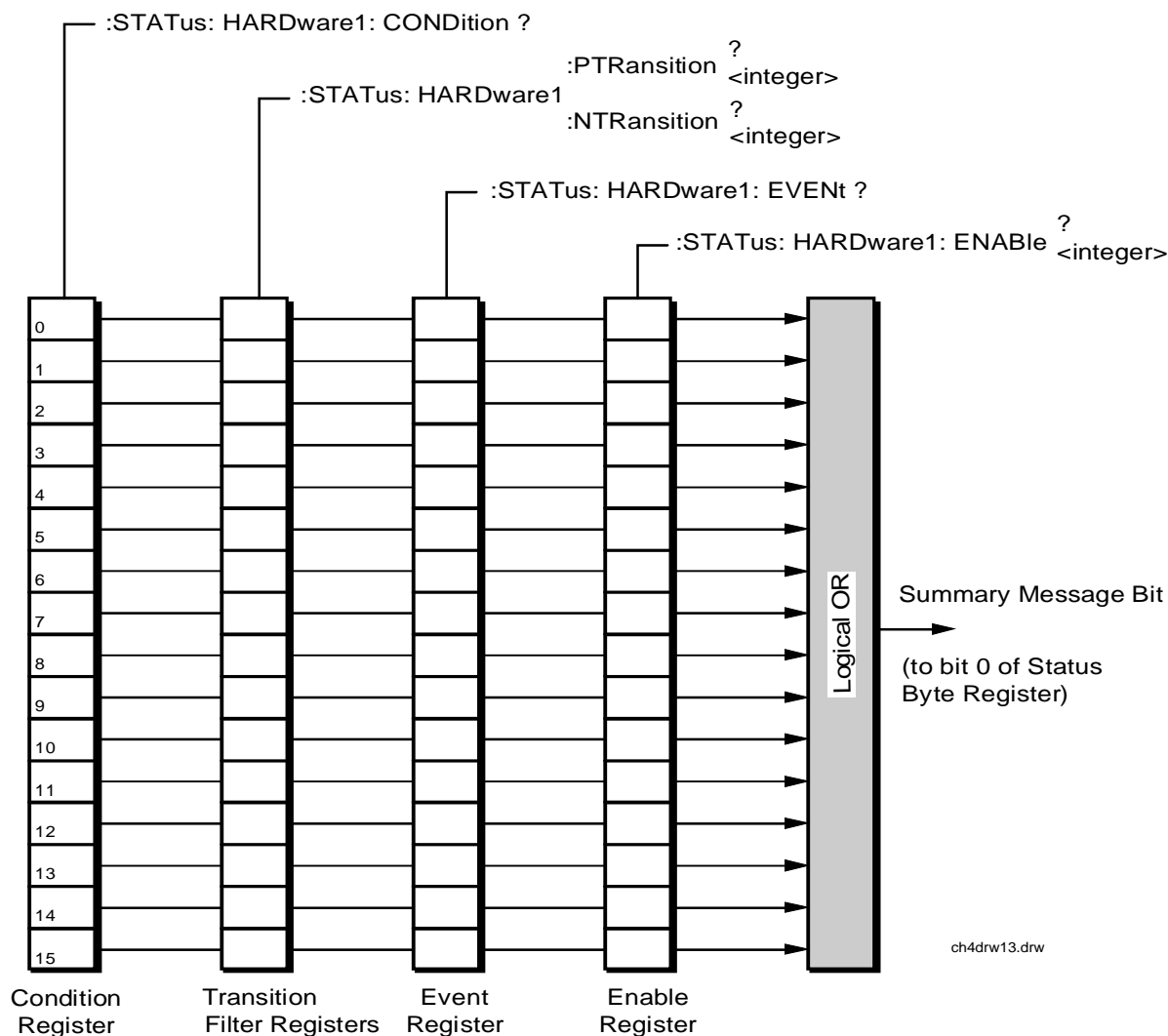

Table 6-8 on page 161 shows the Hardware Status Register Group #1's Condition Register bit assignments.



**Table 6-8 Hardware Status Register Group #1, Condition Register Bit Assignments**

Bit Number	Binary Weighting	Condition	Comment
15	32768	Not Used (Always 0)	Defined by SCPI Version 1994.0
14	16384	Radio Interface Card Interrupt #2 Tripped	
13	8192	Radio Interface Card Interrupt #1 Tripped	
12	4096	Signaling Decoder Measurement Results Available	
11	2048	Signaling Decoder Input Level Too Low	
10	1024	Signaling Decoder is Measuring	
9	512	Signaling Decoder is Armed	
8	256	Signaling Encoder Sending Auxiliary Information	If the Signaling Mode selected has two information fields, such as the AMPS Filler and Message fields, and both fields are being sent, this bit will be set.
7	128	Signaling Encoder Sending Information	If the Signaling Mode selected has only one information field and the field is being sent, this bit will be set high. If the Signaling Mode selected has two information fields, such as the AMPS Filler and Message fields, and only one field is being sent, this bit will be set high. This bit is not active if the Signaling Encoder Mode is set to Function Generator.
6	64	Communication Register Group Summary Message	1 = one or more of the enabled events have occurred since the last reading or clearing of the Event Register.
5	32	Measurement Limit(s) Exceeded	This bit is set high if the Measurement High Limit or Low Limit is exceeded.
4	16	Power-up Self Test(s) Failed	
3	8	Overpower Protection Tripped	
2	4	Unused in Test Set	
1	2	External Mike Keyed	
0	1	External Battery Voltage Low	

## Accessing the Hardware Status Register #1 Group's Registers

The following sections show the syntax and give programming examples (using the HP BASIC programming language) for the STATus commands used to access the Hardware Status Register #1 Group's registers.

### Reading the Condition Register.

#### Syntax

```
STATus:HARDware1:CONDition?
```

#### Example

```
OUTPUT 714;"STAT:HARD1:COND?"  
ENTER 714;Register_value
```

### Reading the Transition Filters.

#### Syntax

```
STATus:HARDware1:PTRansition?  
STATus:HARDware1:NTRansition?
```

#### Example

```
OUTPUT 714;"STAT:HARD1:PTR?"  
ENTER 714;Register_value
```

### Writing the Transition Filters.

#### Syntax

```
STATus:HARDware1:PTRansition <integer>  
STATus:HARDware1:NTRansition <integer>
```

#### Example

```
OUTPUT 714;"STAT:HARD1:PTR 256"
```

## Reading the Event Register.

### Syntax

```
STATus:HARDware1:EVENT?
```

### Example

```
OUTPUT 714;"STAT:HARD1:EVEN?"  
ENTER 714;Register_value
```

## Clearing the Event Register.

The EVENT register is cleared whenever it is queried or whenever the Common Command \*CLS is sent to the Test Set.

## Reading the Enable Register.

### Syntax

```
STATus:HARDware1:ENABle?
```

### Example

```
OUTPUT 714;"STAT:HARD1:ENAB?"  
ENTER 714;Register_value
```

## Writing the Enable Register.

### Syntax

```
STATus:HARDware1:ENABle <integer>
```

### Example

```
OUTPUT 714;"STAT:HARD1:ENAB 256"
```

## Clearing the Enable Register.

The ENABLE register is cleared by writing to it with an integer value of zero.

## Communicate Status Register Group

The Communicate Status Register Group contains information about the Test Set's hardware. This status group is accessed using the STATus commands. The Communicate Status Register Group uses 16-bit registers and includes a Condition Register, Transition Filters, an Event Register, an Enable Register, and a Summary Message. Refer to the "Status Reporting Structure Overview" on page 122 for a discussion of status register operation. Figure 6-14 shows the structure and STATus commands for the Communicate Status Register Group.

**Figure 6-14** Communicate Status Register Group

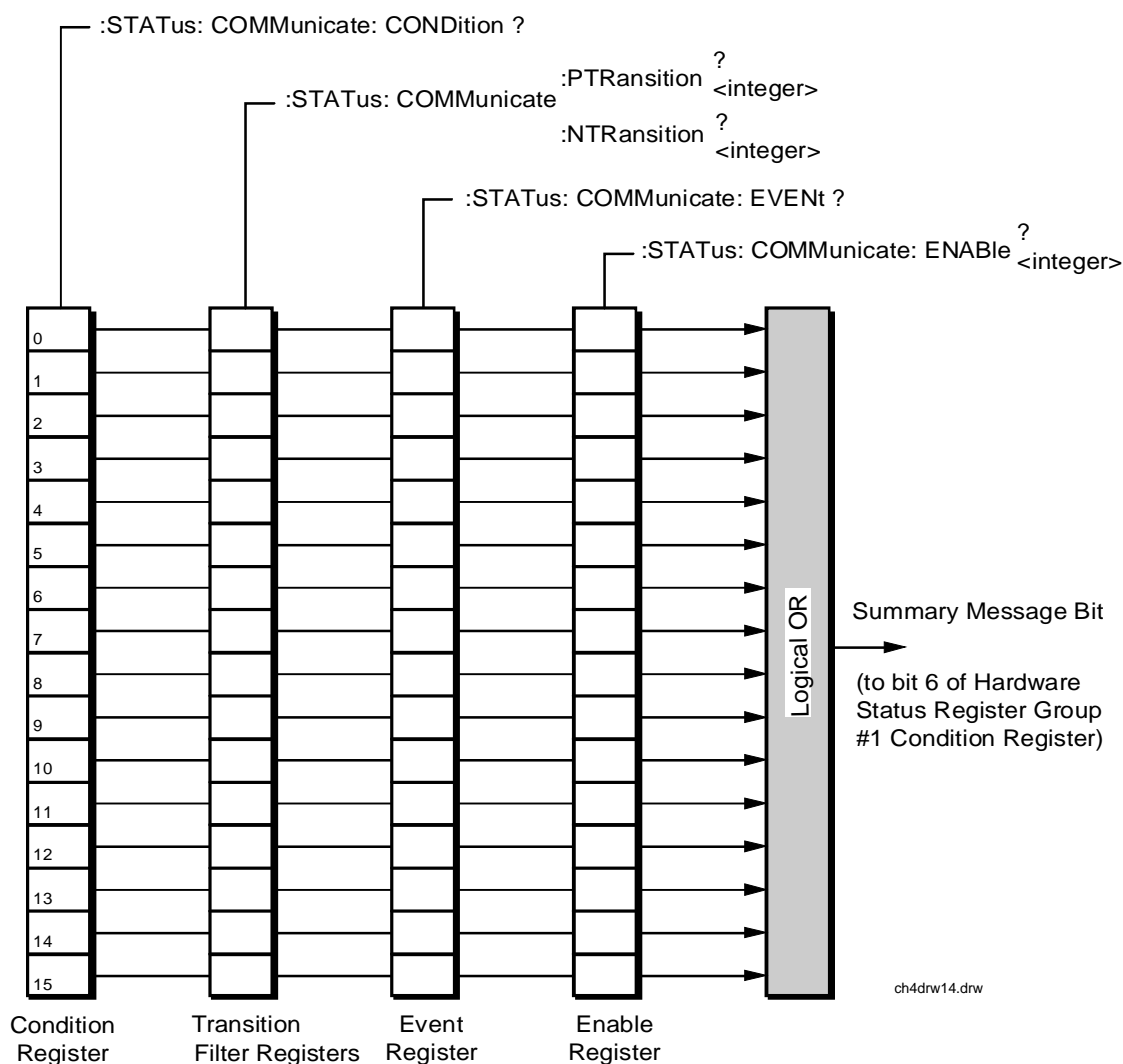

Table 6-9 on page 165 shows the Communicate Status Register Group's Condition Register bit assignments.

**Table 6-9                    Communicate Status Register Group, Condition Register Bit Assignments**

<b>Bit Number</b>	<b>Binary Weighting</b>	<b>Condition</b>	<b>Comment</b>
15	32768	Not Used (Always 0)	Defined by SCPI Version 1994.0
14	16384	Unused in Test Set	
13	8192	Unused in Test Set	
12	4096	Unused in Test Set	
11	2048	Unused in Test Set	
10	1024	Unused in Test Set	
9	512	Unused in Test Set	
8	256	Unused in Test Set	
7	128	Unused in Test Set	
6	64	Unused in Test Set	
5	32	Unused in Test Set	
4	16	Unused in Test Set	
3	8	Unused in Test Set	
2	4	Unused in Test Set	
1	2	TX DSP Analyzer Communication Channel Failure	
0	1	RX DSP Analyzer Communication Channel Failure	

## Accessing the Communicate Status Register Group's Registers

The following sections show the syntax and give programming examples (using the HP BASIC programming language) for the STATUS commands used to access the Communicate Status Register Group's registers.

### Reading the Condition Register.

#### Syntax

```
STATUS:COMMunicate:CONDition?
```

#### Example

```
OUTPUT 714;"STAT:COMM:COND?"  
ENTER 714;Register_value
```

### Reading the Transition Filters.

#### Syntax

```
STATUS:COMMunicate:PTRansition?  
STATUS:COMMunicate:NTRansition?
```

#### Example

```
OUTPUT 714;"STAT:COMM:PTR?"  
ENTER 714;Register_value
```

### Writing the Transition Filters.

#### Syntax

```
STATUS:COMMunicate:PTRansition <integer>  
STATUS:COMMunicate:NTRansition <integer>
```

#### Example

```
OUTPUT 714;"STAT:COMM:PTR 256"
```

## Reading the Event Register.

### Syntax

```
STATus:COMMunicate:EVENT?
```

### Example

```
OUTPUT 714;"STAT:COMM:EVEN?"  
ENTER 714;Register_value
```

## Clearing the Event Register.

The EVENT register is cleared whenever it is queried or whenever the Common Command \*CLS is sent to the Test Set.

## Reading the Enable Register.

### Syntax

```
STATus:COMMunicate:ENABle?
```

### Example

```
OUTPUT 714;"STAT:COMM:ENAB?"  
ENTER 714;Register_value
```

## Writing the Enable Register.

### Syntax

```
STATus:COMMunicate:ENABle <integer>
```

### Example

```
OUTPUT 714;"STAT:COMM:ENAB 256"
```

## Clearing the Enable Register.

The ENABLE register is cleared by writing to it with an integer value of zero.

## HP-IB Service Requests

The Test Set is capable of generating a “service request” when it requires the Active Controller to take action. Service requests are generally made after the Test Set has completed a task (such as making a measurement) or when an error condition exists (such as an internal self-calibration has failed).

The mechanism by which the Active Controller detects these requests is the SRQ interrupt. Interrupts allow for efficient use of system resources, because the Active Controller may be executing a program until an SRQ interrupt occurs. If SRQ interrupts are enabled in the Active Controller, the occurrence of an interrupt can initiate a program branch to a routine which “services” the interrupt (executes some remedial action). The operating and/or programming manuals for each controller describe the controller’s capability to set up and respond to SRQ interrupts.

This section describes the steps necessary to properly configure the Test Set to request service using the Service Request (SRQ) function.

### Setting Up and Enabling SRQ Interrupts

Test Set status information is maintained in eight register groups. Information in each register group is summarized into a Summary Message. All of the Summary Messages are, in turn, summarized into the Status Byte Register, either directly to specific bit positions in the Status Byte Register as shown in [Table 6-10 on page 169](#), or indirectly through another register group (refer to “[Status Reporting Structure Overview](#)” on [page 122](#) for a detailed discussion of the register groups and status reporting).



**Table 6-10 Status Byte Register Bit Assignments**

<b>Bit Position</b>	<b>Binary Weighting</b>	<b>Assignments</b>
7	128	Operation Status Register Group Summary Message
6	64	Request Service (RQS) message when read by serial poll, <i>or</i> , Master Summary Status (MSS) message when read by STB? command
5	32	Standard Event Status Bit (ESB) Summary Message
4	16	Output Queue Message Available (MAV) Summary Message
3	8	Questionable Data/Signal Register Group Summary Message
2	4	Unused in Test Set
1	2	Hardware #2 Status Register Group Summary Message
0	1	Hardware #1 Status Register Group Summary Message

Bits in the Status Byte Register can be used to generate a Service Request (SRQ) message by enabling the associated bit in the Service Request Enable Register. When an enabled service request condition exists, the Test Set sends the Service Request message (SRQ) on the HP-IB bus and reports that it has requested service by setting the Request Service (RQS) bit in the Status Byte register to the TRUE, logic 1, state. When read by a serial poll, the RQS bit is cleared (set to logic 0) so that the RQS message will be FALSE if the Test Set is polled again before a new reason for requesting service has occurred.

## Service Request Enable Register

Service request enabling allows the application programmer to select which Summary Messages in the Status Byte Register may cause a service request. The Service Request Enable Register, illustrated in Figure 6-15, is an 8-bit register that enables corresponding Summary Messages in the Status Byte Register.

**Figure 6-15** Service Request Enable Register

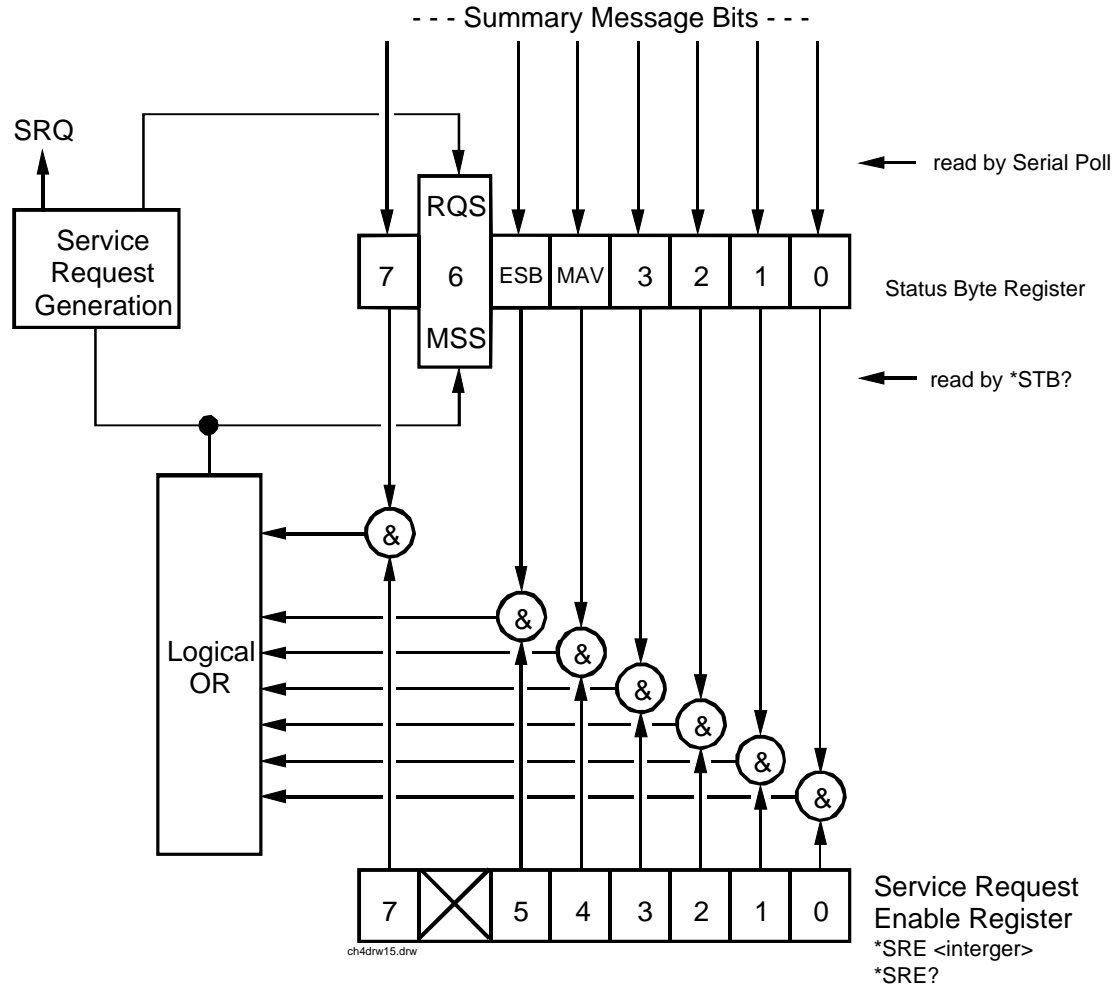

## Reading the Service Request Enable Register

The Service Request Enable Register is read with the \*SRE? Common Command. The \*SRE? query allows the programmer to determine the current contents (bit pattern) of the Service Request Enable Register. The Test Set responds to the \*SRE? query by placing the binary-weighted decimal value of the Service Request Enable Register bit pattern into the Output Queue. The decimal value of the bit pattern will be a positive integer in the range 0 to 255. The response data is obtained by reading the Output Queue into a numeric variable, integer or real.

### Example BASIC program

```
10 INTEGER Srv_rqs_enab_rg
20 OUTPUT 714; "*SRE?"
30 ENTER 714;Srv_rqs_enab_rg
40 PRINT Srv_rqs_enab_rg
50 END
```

### Example response

```
18
```

## Writing the Service Request Enable Register

The Service Request Enable Register is written with the \*SRE Common Command. The \*SRE command sets the bit pattern (bits 0-5 and 7) of the Service Request Enable Register. The Service Request Enable Register allows the programmer to select which condition(s), as defined by bits 0-5 and 7 of the Status Byte Register, will generate a Service Request on the HP-IB bus. The Test Set always ignores bit 6 (binary weight 64) of the bit pattern set by the \*SRE command.

The bit pattern set by the \*SRE command is determined by selecting the desired condition(s) from the Status Byte Register, setting the value of the bit position(s) to a logical one, setting the value of all non-selected bit positions to a logical zero, and sending the binary-weighted decimal equivalent of bits 0-5 and 7 after the \*SRE command. For example, if the programmer wished to have the occurrence of a message available in the Output Queue (bit position 4 in the Status Byte Register) and the occurrence of a condition in the Hardware# 2 Status Register (bit position 1 in the Status Byte Register) to generate a Service Request on the HP-IB bus, the binary-weighted decimal value of the bit pattern for the Service Request Enable Register would be determined as shown in [Table 6-11 on page 172](#).

**Table 6-11 Determining the Service Request Enable Register Bit Pattern**

Bit Position	7	6	5	4	3	2	1	0	
Logical Value	0	X	0	1	0	0	1	0	X = ignored by the Test Set
Binary Weighting	128	X	32	16	8	4	2	1	X = ignored by the Test Set
Decimal Value	0+	0+	0+	16+	0+	0+	2+	0	= 18

**Example**

OUTPUT 714: "\*SRE 18"

**NOTE**

The decimal value of the bit pattern must be a positive integer in the range of 0 to 255. Sending a negative number or a number greater than 255 causes an HP-IB Error: -222 Data out of range.

**Clearing the Service Request Enable Register**

The Service Request Enable Register is cleared by sending the \*SRE Common Command with a decimal value of zero. Clearing the Service Request Enable Register turns off service requests.

**Procedure for Generating a Service Request**

The following steps outline a generalized procedure for properly setting up the Test Set to generate a Service Request (SRQ) message to the Active Controller. This procedure does not include instructions for setting up the Active Controller to respond to the Service Request message generated by the Test Set. Refer to the operating and/or programming manuals for each controller for information describing the controller's capability to set up and respond to SRQ interrupts.

- For register groups with Condition Registers and Transition Filters start at step 1.
  - For register groups with no Condition Register or Transition Filters start at step 5.
1. Determine which conditions, as defined by their bit positions in the Register Group Condition Register, should cause the Summary Message to be set TRUE if they occur.
  2. Determine the polarity of the bit-state transition which will indicate that the condition has occurred.
  3. Set the Register Group Transition Filters to the correct polarity to pass the bit-state transition to the Event Register.
  4. Go to step 6.

5. Determine which conditions, as defined by their bit positions in the Register Group Event Register, should cause the Summary Message to be set TRUE if they occur.
6. Set the correct bits in the Register Group Enable Register to generate the Summary Message if the condition has been latched into the Register Group Event Register.
7. If the Summary Message is a bit in a Register Group that is not the Status Byte Register go to step 1.
8. Set the correct bits in the Service Request Enable Register for all Register Group Summary Messages selected in steps 1 through 6.

## Example BASIC Program to Set Up and Service an SRQ Interrupt

The following HP BASIC program was written for an HP 9000 Series 300 Controller and a Test Set. The program assumes that the Test Set is the only instrument on the bus. The program sets up an interrupt from the Standard Event Status Register Group, the Calibration Status Register Group, and the Hardware Status Register #1 Group. For demonstration purposes the program is written to stay in a dummy loop waiting for an interrupt from the Test Set

### Example

```
10 OPTION BASE 1
20 COM/Io_names/INTEGER Inst_address,Std_event_reg,Calibration_reg
30 COM /Io_names/ INTEGER Hardware1_reg,Srq_enab_reg,Status_byte,Event_reg
40 !
50 ! Define instrument address
60 Inst_address=714
70 !
80 PRINTER IS CRT
90 CLEAR SCREEN
100 !
110 ! Reset the Test Set to bring it to a known state
120 OUTPUT Inst_address;"*RST"
130 !
140 ! Clear the Test Set status reporting system
150 OUTPUT Inst_address;"*CLS"
160 !
170 ! Set up the desired interrupt conditions in the Test Set:
180 !
190 ! 1) Standard Event Status Register Group
200 !   Event register conditions which will set the Summary Message
210 !   TRUE if they occur:
220 !   Bit 5: Command Error           decimal value = 2^5 = 32
230 !   Bit 4: Execution Error         decimal value = 2^4 = 16
240 !   Bit 3: Device Dependent Error  decimal value = 2^3 = 8
250 !   Bit 2: Query Error             decimal value = 2^2 = 4
260 !
270 Std_event_reg=32+16+8+4
280 !
290 !   Set up the Standard Event Status Enable Register to generate the
300 !   Summary Message
310 !
320 OUTPUT Inst_address;"*ESE";Std_event_reg
330 !
340 ! 2) Calibration Status Register Group
350 !   Condition register conditions which will set the Summary Message
360 !   TRUE if they occur:
370 !   Bit 4: TX Auto-zero failed      decimal value = 2^4 = 16
380 !   Bit 3: Voltmeter Self-cal failed decimal value = 2^3 = 8
390 !   Bit 2: Counter Self-cal failed  decimal value = 2^2 = 4
400 !   Bit 1: Sampler Self-cal failed  decimal value = 2^1 = 2
410 !   Bit 0: Spec Anal Self-cal failed decimal value = 2^0 = 1
420 !
430 Calibration_reg=16+8+4+2+1
440 !
450 !   Set the Transition Filters to allow only positive transitions in
460 !   the assigned condition(s) to pass to the Event Register
470 !
480 OUTPUT Inst_address;"STAT:CAL:PTR";Calibration_reg
490 OUTPUT Inst_address;"STAT:CAL:NTR 0"
500 !
510 ! Set up the Calibration Status Register Group Enable Register to
520 ! generate the Summary Message.
530 !
540 OUTPUT Inst_address;"STAT:CAL:ENAB";Calibration_reg
550 !
```

```

560 ! The Calibration Status Register Group Summary Message is passed to
570 ! the Status Byte Register through Bit 8 in the Questionable
580 ! Data/Signal Register Group Condition Register. The Questionable
590 ! Data/Signal Register Group must be configured to set its Summary
600 ! Message TRUE if the Summary Message from the Calibration Status
610 ! Register Group is TRUE. Therefore Bit 8 ( $2^8=256$ ) in the Questionable
620 ! Data/Signal Register Group Enable Register must be set HIGH.
630 !
640 OUTPUT Inst_address;"STAT:QUES:ENAB 256"
650 !
660 ! 3) Hardware Status Register #1 Group
670 ! Condition register conditions which will set the Summary Message
680 ! TRUE if they occur:
690 ! Bit 5: Measurement limits exceeded decimal value =  $2^5 = 32$ 
700 ! Bit 4: Power-up Self-test failed decimal value =  $2^4 = 16$ 
710 ! Bit 3: Overpower protection tripped decimal value =  $2^3 = 8$ 
720 !
730 Hardware1_reg=32+16+8
740 !
750 ! Set the Transition Filters to allow only positive transitions in
760 ! the assigned condition(s) to pass to the Event Register
770 !
780 OUTPUT Inst_address;"STAT:HARD1:PTR";Hardware1_reg
790 OUTPUT Inst_address;"STAT:HARD1:NTR 0"
800 !
810 ! Set up the Hardware Status Register #1 Group Enable Register to
820 ! generate the Summary Message.
830 !
840 OUTPUT Inst_address;"STAT:HARD1:ENAB";Hardware1_reg
850 !
860 ! 4) Set the correct Summary Message bit(s) in the Service Request
870 ! Enable Register to generate a Service Request (SRQ) if the
880 ! Summary Message(s) become TRUE.
890 ! Bit 5 = Standard Event Status Register Summary Message
900 ! decimal value =  $2^5 = 32$ 
910 ! Bit 3 = Questionable Data/Signal Register Group Summary Message
920 ! decimal value =  $2^3 = 8$ 
930 ! Bit 0 = Hardware Status Register #1 Group Summary Message
940 ! decimal value =  $2^0 = 1$ 
950 !
960 Srq_enab_reg=32+8+1
970 OUTPUT Inst_address;"*SRE";Srq_enab_reg
980 !
990 ! 5) Set up the Active Controller to respond to an SRQ interrupt:
1000 ! Call subprogram Check_interrupt if an SRQ condition exists on select
1010 ! code 7. The interrupt priority level is set to 15 (highest level).
1020 !
1030 ON INTR 7,15 CALL Srvice_interupt
1040 !
1050 ! 6) Enable interrupts on select code 7:
1060 ! The interface mask is set to a value of 2 which enables interrupts on
1070 ! the HP-IB bus when the SRQ line is asserted.
1080 !
1090 ENABLE INTR 7;2
1100 !
1110 ! Start of the dummy loop:
1120 !
1130 LOOP
1140 DISP "I am sitting in a dummy loop."
1150 END LOOP
1160 !
1170 END
1180 !
1190 Srvice_interupt:SUB Srvice_interupt
1200 !
1210 OPTION BASE 1
1220 COM /Io_names/ INTEGER Inst_address,Std_event_reg,Calibration_reg
1230 COM / Io_names/ INTEGER Hardware1_reg,Srq_enab_reg,Status_byte,Event_reg
1240 !
1250 !Turn off interrupts while processing the current interrupt.
1260 OFF INTR 7
1270 !
1280 !Conduct a SERIAL POLL to read the Status Byte and clear the SRQ:
1290 !
1300 Status_byte=SPOLL(Inst_address)

```

## Advanced Operations

### HP-IB Service Requests

```
1310 !
1320 ! Determine which Register Group(s) caused the interrupt. Since three
1330 ! were enabled, all three must be checked:
1340 !
1350 IF BIT(Status_byte,5) THEN GOSUB Srvice_std_evnt
1360 IF BIT(Status_byte,3) THEN GOSUB Srvice_calib
1370 IF BIT(Status_byte,0) THEN GOSUB Srvice_hard1
1380 !
1390 ! Re-enable the interrupt before leaving the service routine
1400 !
1410     ENABLE INTR 7;2
1420 SUBEXIT
1430!
1440 Srvice_std_evnt:!
1450 ! This routine would determine which bit(s) in the Standard Event
1460 ! Status Register are TRUE, logic 1, and take appropriate action.
1470 ! NOTE: Read the Event Register to clear it. If the Event Register is
1480 ! not cleared it will NOT latch another event, thereby preventing
1490 ! the Test Set from generating another SRQ.
1500 !
1510 OUTPUT Inst_address;"*ESR?"
1520 ENTER Inst_address;Event_reg
1530 RETURN
1540 !
1550 Srvice_calib:!
1560 ! This routine would determine which bit(s) in the Calibration Status
1570 ! Register Group Event Register are TRUE, logic 1, and take
1580 ! appropriate action.
1590 ! NOTE: Read the Event Register to clear it. If the Event Register is
1600 ! not cleared it will NOT latch another event from the Condition
1610 ! Register, thereby preventing the Test Set from generating another SRQ.
1620 !
1630 OUTPUT Inst_address;"STAT:CAL:EVEN?"
1640 ENTER Inst_address;Event_reg
1650 RETURN
1660 !
1670 Srvice_hard1:!
1680 ! This routine would determine which bit(s) in the Hardware Status
1690 ! Register #1 Group Event Register are TRUE, logic 1, and take
1700 ! appropriate action.
1710 ! NOTE: Read the Event Register to clear it. If the Event Register is
1720 ! not cleared it will NOT latch another event from the Condition
1730 ! Register, thereby preventing the Test Set from generating another SRQ.
1740 !
1750 OUTPUT Inst_address;"STAT:HARD1:EVEN?"
1760     ENTER Inst_address;Event_reg
1770 RETURN
1780 !
1790 SUBEND
```



## Instrument Initialization

This section discusses the various methods available to the programmer to initialize the Test Set to a known state.

With over 22 instruments utilizing greater than 25 screens containing hundreds of fields which can be programmed through the HP-IB bus, a hard copy list of the default condition for every field in every instrument screen would be cumbersome. The recommended method of determining the default condition for every field in a particular instrument screen is to select the PRESET key, display the instrument screen of interest and view the contents of the fields.

Apart from the individual instruments it is important, from a programmatic perspective, to know the default conditions of the I/O configuration of the Test Set and how it may be affected by the various methods of initialization. Seven screens are used to control the I/O configuration of the Test Set:

- INSTRUMENT CONFIGURE screen
- I/O CONFIGURE screen
- PRINTER CONFIGURE screen
- SOFTWARE MENU screen
- TESTS (Execution Conditions) screen
- TESTS ( External Devices) screen
- TESTS (Printer Setup) screen

The following sections discuss how the various methods of initialization affect these seven screens as well as the Status Reporting Structure of the Test Set.

## Methods of Initialization

There are six methods of initializing the Test Set:

1. Power On Reset
2. Front panel PRESET key
3. \*RST IEEE 488.2 Common Command
4. Device Clear (DCL) HP-IB Bus Command
5. Selected Device Clear (SDC) HP-IB Bus Command
6. Interface Clear (IFC) HP-IB Bus Command

When the Test Set is initialized some fields are “restored” (put back to their default state), some fields are “maintained” (kept at their current state or value), and some fields are “initialized” (returned to their default value).

The following sections discuss the effects each of the six initialization methods has on the Test Set.

## Power-On Reset

The Power-On Reset is accomplished by applying or cycling AC/DC power to the Test Set.

For the INSTRUMENT CONFIGURE, PRINTER CONFIGURE, TESTS (Execution Conditions), TESTS (Printer Setup) and I/O CONFIGURE screens, [Table 6-12 on page 179](#) lists the fields which are restored/initialized when the Test Set AC/DC power is cycled. The restored state or initialized value is listed below the field name. Fields which are not listed are maintained at their current value, whatever that may happen to be. All fields in the SOFTWARE MENU screen and the TESTS (External Devices) screen are maintained at their current state/value. The current state/value of the maintained fields can be ascertained programmatically.

**Table 6-12** Screen Fields Restored/Initialized During Power-On Reset or Front Panel Reset

<b>INSTRUMENT CONFIGURE Screen Fields</b>	<b>PRINTER CONFIGURE Screen Fields</b>	<b>TESTS (Execution Conditions) Screen Fields</b>	<b>TESTS (Printer Setup) Screen Fields</b>	<b>I/O CONFIGURE</b>
	Print Title field is cleared.	Test output location: Crt	Test output location: Crt	Save/Recall: Internal
RF Offset: Off		Results output: All	Results output: All	
(Gen)-(Anl): Not displayed		If Unit Under Test Fails: Continue		
Range Hold: Auto State		Test Procedure Run Mode: Continuous		
Notch Coupl: None				
RF Display: Chan				
RF Chan Std: N AMER PCS				
RF Level Offset: Off				
RF In/Out: 0.0				
Duplex Out: 0.0				
Antenna In: 0.0				

The Power-On Reset condition in the Test Set was specifically designed to configure the instruments for manual testing of an FM radio. The Power-On Reset default display screen is the RX TEST screen. Other operational characteristics are also affected by the Power-On Reset as follows:

- The Power-up self-test diagnostics are performed.
- The Contents of the SAVE/RECALL registers are not affected.
- All pending operations are aborted.
- Measurement triggering is set to TRIG:MODE:SETT FULL;RETR REP
- All Enable registers are cleared: Service Request, Standard Event, Communicate, Hardware #1, Hardware #2, Operation, Calibration, and Questionable Data/Signal.
- All Negative Transition Filter registers are initialized to all zeros: Communicate, Hardware #1, Hardware #2, Operation, Calibration, and Questionable Data/Signal.
- All Positive Transition Filter registers are initialized to all ones: Communicate, Hardware #1, Hardware #2, Operation, Calibration, and Questionable Data/Signal.
- Any previously received Operation Complete command (\*OPC) is cleared.
- Any previously received Operation Complete query command (\*OPC?) is cleared.
- Calibration data is not affected.
- The HP-IB interface is reset (any pending Service Request is cleared.)
- The contents of the RAM are unaffected.
- The Test Set's display screen is in the UNLOCKED state.

## Front-panel PRESET Key

The Front-panel Reset is accomplished by pressing the PRESET key on the front panel of the Test Set.

For the INSTRUMENT CONFIGURE, PRINTER CONFIGURE, TESTS (Execution Conditions), TESTS (Printer Setup) and I/O CONFIGURE screens, [Table 6-12 on page 179](#) lists the fields which are restored/initialized when the front-panel Preset key is pressed. The restored state or initialized value is listed below the field name. Fields which are not listed are maintained at their current value, whatever that may happen to be. All fields in the SOFTWARE MENU screen and the TESTS (External Devices) screen are maintained at their current state/value. The current state/value of the maintained fields can be ascertained programmatically.

The Front-panel Reset condition in the Test Set was specifically designed to configure the instruments for manual testing of an FM radio. The Front-panel Reset default display screen is the RX TEST screen. Other operational characteristics are also affected by the Front-panel Reset as follows:

- All pending operations are aborted.
- Measurement triggering is set to TRIG:MODE:SETT FULL;RETR REP.
- Any previously received Operation Complete command (\*OPC) is cleared.
- Any previously received Operation Complete query command (\*OPC?) is cleared.
- The Test Set's display screen is in the UNLOCKED state.
- The Power-up self-test diagnostics are not performed.
- The HP-IB interface is not reset (any pending Service Request is not cleared.)
- The Contents of the SAVE/RECALL registers are not affected.
- Calibration data is not affected.
- All Enable registers are unaffected: Service Request, Standard Event, Communicate, Hardware #1, Hardware #2, Operation, Calibration, and Questionable Data/Signal.
- All Negative Transition Filter registers are unaffected: Communicate, Hardware #1, Hardware #2, Operation, Calibration, and Questionable Data/Signal.
- All Positive Transition Filter registers are unaffected: Communicate, Hardware #1, Hardware #2, Operation, Calibration, and Questionable Data/Signal.
- The contents of the RAM are unaffected.

## \*RST IEEE 488.2 Common Command

The \*RST Reset is accomplished by sending the \*RST Common Command to the Test Set through the HP-IB. Table 6-13 lists the fields which are restored/initialized when the \*RST command is received. The restored state or initialized value is listed with the field's name. Fields which are not listed are maintained at their current value. All fields in the SOFTWARE MENU screen and the TESTS (External Devices) screen are maintained. The current state/value of the maintained fields can be ascertained programmatically.

**Table 6-13** Screen Fields Restored/Initialized During \*RST Reset (Continued)

<b>INSTRUMENT CONFIGURE Screen Fields</b>	<b>PRINTER CONFIGURE Screen Fields</b>	<b>TESTS (Execution Conditions) Screen Fields</b>	<b>TESTS (Printer Setup) Screen Fields</b>	<b>I/O CONFIGURE</b>
RF Offset: Off	Print Title field is cleared	Test output location: Crt	Test output location: Crt	Save/Recall: Internal
(Gen)-(Anl): 0.000000		Results output: All	Results output: All	
Range Hold: Auto All		If Unit Under Test Fails: Continue		
Notch Coupl: None		Test Procedure Run Mode: Continuous		
RF Display: Freq				
RF Chan Std: MS AMPS				
User Def Base Freq: 800.000000				
Chan Space: 30.0000				
(Gen)-(Anl): 45.000000				
RF Level Offset: Off				
RF In/Out: 0.0				
Duplex Out: 0.0				
Antenna In: 0.0				

The \*RST Reset condition in the Test Set was specifically designed to configure the instruments for manual testing of an FM radio. The \*RST Reset default display screen is the RX TEST screen. Other operational characteristics are also affected by the \*RST reset as follows:

- All pending operations are aborted.
- Measurement triggering is set to TRIG:MODE:SETT FULL;RETR REP.
- Any previously received Operation Complete command (\*OPC) is cleared.
- Any previously received Operation Complete query command (\*OPC?) is cleared.
- The Test Set's display screen is in the UNLOCKED state.
- The Power-up self-test diagnostics are not performed.
- The Contents of the SAVE/RECALL registers are not affected.
- Calibration data is not affected.
- The HP-IB interface is not reset (any pending Service Request is not cleared).
- All Enable registers are unaffected: Service Request, Standard Event, Communicate, Hardware #1, Hardware #2, Operation, Calibration, and Questionable Data/Signal.
- All Negative Transition Filter registers are unaffected: Communicate, Hardware #1, Hardware #2, Operation, Calibration, and Questionable Data/Signal.
- All Positive Transition Filter registers are unaffected: Communicate, Hardware #1, Hardware #2, Operation, Calibration, and Questionable Data/Signal.
- The contents of the RAM are unaffected.
- The contents of the Output Queue are unaffected.
- The contents of the Error Queue are unaffected.

## Device Clear (DCL) HP-IB Bus Command

The Device Clear (DCL) Reset is accomplished by sending the DCL message to the Test Set through the HP-IB bus.

The DCL command clears the Input Buffer and Output Queue, clears any commands in process, puts the Test Set into the Operation Complete idle state, and prepares the Test Set to receive new commands. The DCL bus command does not change any settings or stored data (except as noted previously), interrupt front panel I/O, interrupt any Test Set operation in progress (except as noted previously), or change the contents of the Status Byte Register (other than clearing the MAV bit as a consequence of clearing the Output Queue).

The DCL bus command has no effect on the I/O CONFIGURE, INSTRUMENT CONFIGURE, PRINTER CONFIGURE, SOFTWARE MENU, or TESTS (Execution Conditions, External Devices, Printer Setup) screens.

Other operational characteristics are also affected by the DCL bus command as follows:

- The Power-up self-test diagnostics are not performed.
- The HP-IB interface is not reset (any pending Service Request is not cleared)
- Measurement triggering is not affected.
- Calibration data is not affected.
- The Contents of the SAVE/RECALL registers are not affected.
- All Enable registers are unaffected: Service Request, Standard Event, Hardware #1, Hardware #2, Operation, Calibration, and Questionable Data/Signal.
- All Negative Transition Filter registers are unaffected: Hardware #1, Hardware #2, Operation, Calibration, and Questionable Data/Signal.
- All Positive Transition Filter registers are unaffected: Hardware #1, Hardware #2, Operation, Calibration, and Questionable Data/Signal.
- The contents of the RAM are unaffected.
- The contents of the Error Queue are unaffected.
- The state of the Test Set's display screen is unaffected.



## **Selected Device Clear (SDC) HP-IB Bus Command**

The Selected Device Clear (SDC) Reset is accomplished by sending the SDC message to the Test Set through HP-IB. The Test Set responds to the Selected Device Clear (SDC) and the Device Clear (DCL) bus commands equally. Refer to the [“Device Clear \(DCL\) HP-IB Bus Command” on page 184](#) for a description of the effects of the SDC Reset.

## Interface Clear (IFC) HP-IB Bus Command

The Interface Clear (IFC) Reset is accomplished by having the Active Controller send the ABORT message to the HP-IB bus (ABORT message = IFC bus control line TRUE for 100 ms).

The IFC bus command unconditionally terminates all HP-IB bus activity and the Test Set is unaddressed.

The IFC bus command has no effect on the I/O CONFIGURE, INSTRUMENT CONFIGURE, PRINTER CONFIGURE, SOFTWARE MENU or TESTS (Execution Conditions, External Devices, Printer Setup) screens.

Other operational characteristics are also affected by the IFC bus command as follows:

- The Power-up self-test diagnostics are not performed.
- The HP-IB interface is not reset (any pending Service Request is not cleared).
- The Contents of the SAVE/RECALL registers are not affected.
- Measurement triggering is not affected.
- Calibration data is not affected .
- All Enable registers are unaffected: Service Request, Standard Event, Hardware #1, Hardware #2, Operation, Calibration, and Questionable Data/Signal.
- All Negative Transition Filter registers are unaffected: Hardware #1, Hardware #2, Operation, Calibration, and Questionable Data/Signal.
- All Positive Transition Filter registers are unaffected: Hardware #1, Hardware #2, Operation, Calibration, and Questionable Data/Signal.
- The contents of the RAM are unaffected.
- The contents of the Error Queue are unaffected.
- The contents of the Output Queue are unaffected.
- The state of the Test Set display screen is not affected

---

## Passing Control

Communications on the HP-IB bus are accomplished according to a precisely defined set of rules (IEEE 488.1 and 488.2 Standards). Communication (data transfer) is accomplished by designating one device to be a talker (source of data or commands) and designating one or more devices to be listeners (receivers of data or commands). The device on the bus responsible for designating talkers and listeners is the Controller.

The structure of the HP-IB bus allows for more than one Controller to be connected to the bus at the same time. As a means of ensuring that orderly communications can be established on power-up or when communications have failed, the rules state that only one Controller can unconditionally demand control of the bus (through the IFC line). This controller is referred to as the System Controller. There can be only one System Controller connected to the bus at any time.

As a means of ensuring orderly communications in environments where more than one controller is connected to the bus, the rules state that only one Controller can be actively addressing talkers and listeners at any given time. This device is referred to as the Active Controller. The System Controller is the default Active Controller on power-up or after a bus reset. Controllers which are not the Active Controller are referred to as Non-Active Controllers. The Active Controller can pass control of device addressing to one of the Non-Active Controllers. Additionally, Non-Active Controllers can request control from the Active Controller.

The process by which the Active Controller passes device addressing responsibility to a Non-Active Controller is referred to as Passing Control. The Active Controller must first address the prospective new Active Controller to Talk, after which it sends the Take Control Talker (TCT) message across the bus. If the other Controller accepts the message it assumes the role of Active Controller and the previous Active Controller becomes a Non-Active Controller.

The Test Set has bus control capability (Active/Non-Active Controller). Additionally the Test Set can be also be configured as the System Controller. By definition then, the Test Set has the capability to demand control, pass control, accept control, and request control of the bus depending upon its configuration, its current operating mode, and the system configuration. Many possibilities for passing control among several controllers on the same bus exist. Attempting to identify all the possible techniques of passing control in such a system is beyond the scope of this document (refer to the IEEE 488.1 and 488.2 Standards for additional information).

## Configuring the Test Set as the System Controller

To configure the Test Set as a System Controller, select the I/O CONFIGURE screen, position the cursor to the Mode field using the Cursor Control knob, highlight the Mode field by pushing the Rotary Knob, select Control from the Choices menu. As a consequence of setting the Test Set to be the System Controller it will also become the Active Controller. The letter C appears in the upper-right corner of the display to indicate that the Test Set is now the Active Controller.

If the Test Set is the only controller on the bus it must be configured as the System Controller. If the Test Set is not the only controller on the bus, then whether or not it is configured as the System Controller would depend upon three issues:

1. whether or not other controllers have System Controller capability
2. which controller will be the Active Controller upon power-up
3. which Controller will be monitoring the bus to determine if communications have failed (only the System Controller can unconditionally demand control of the bus and reset it to a known state using the IFC line)

Ensure that only one Controller connected to the bus is configured as the System Controller or bus conflicts will occur.

## When Active Controller Capability is Required

The Test Set must be the Active Controller on the bus under the following conditions:

1. whenever the Test Set needs to control any device connected to the HP-IB bus, such as an external disk drive, an external printer, or an external instrument
2. whenever a screen image is printed to an external HP-IB printer
3. Whenever an instrument configuration is saved or recalled from an external HP-IB disk drive
4. Whenever running any HP Test Software package which uses an external HP-IB device such as a printer, or an instrument
5. Whenever running any IBASIC program which uses an external HP-IB device such as a printer, or an instrument

## Passing Control to the Test Set

Control is passed to the Test Set when it is addressed to TALK and then receives the Take Control Talker (TCT) command. The programming or controller command which implements the pass control protocol as outlined in the IEEE 488.1 and 488.2 Standards is language/controller specific. Refer to the appropriate language/controller documentation for specific implementations.

Before passing control to the Test Set the Active Controller should send the Test Set the address to use when passing control back. This is accomplished using the \*PCB Common Command. The \*PCB command tells the Test Set which address should be used when passing control back to another bus controller. Before passing bus control to the Test Set, the currently active controller can use the \*PCB command to tell the Test Set where to send the Take Control (TCT) command when the Test Set is ready to give up active control of the bus. The command is followed by a number which contains the bus address of the device that should become the next active controller. The number must round to an integer in the range 0 to 30 decimal. The command may be followed by two numbers. The first will be used as the primary address, the second as the secondary address of the next active controller.

## Passing Control Back to Another Controller

The Test Set has two methods of passing control back to another controller: 1) automatically and 2) using the IBASIC PASS CONTROL command from an IBASIC program. The two methods are described in the following sections.

### Passing Control Back Automatically

The Test Set will automatically pass control back to the controller whose address was specified in the \*PCB Common Command or to a default address of 0 (decimal) if no \*PCB command was received. Control will automatically be passed under the following conditions:

#### **Test Set is the Active Controller and an IBASIC Program is Running.**

- The IBASIC program running in the Test Set is PAUSED.
- The IBASIC program running in the Test Set finishes executing.
- An IBASIC RESET occurs while the IBASIC program is running.
- Control is passed back immediately if the System Controller executes a bus reset (IFC).

#### **Test Set is the Active Controller and no IBASIC Program is Running.**

- Control will be passed back within 10 seconds of receiving bus control if no controller commands are executed (such as printing a screen image to an HP-IB printer).
- Control is passed back immediately if the System Controller executes a bus reset (IFC).
- Control is passed back at the completion of a controller command (such as printing a screen image to an HP-IB printer).

### Passing Control Back Using IBASIC PASS CONTROL Command

The Test Set will pass control back to another Controller when the IBASIC PASS CONTROL command is issued while an IBASIC program is running on the built-in IBASIC Controller. Refer to the *HP Instrument BASIC User's Handbook* for a complete description of the IBASIC PASS CONTROL command.

## Requesting Control using IBASIC

The Test Set has the capability to request control of the bus from the Active Controller from a running IBASIC program using the IBASIC command EXECUTE ("REQUEST\_CONTROL"). When the EXECUTE ("REQUEST\_CONTROL") command is executed from a running IBASIC program, the Request Control bit, bit 1, of the Test Set's Standard Event Status Register is set to the TRUE, logic 1, condition. The Active Controller detects the request in the Test Set's Standard Event Status Register either as a result of an SRQ indication by the Test Set or by some polling routine which periodically checks bit 1 of the Standard Event Status Register of all potential controllers on the bus. The Active Controller would then send the Test Set the address to which the Test Set is to later pass control using the \*PCB Common Command. The Active Controller would then pass control to the Test Set.

## Pass Control Examples

The following examples illustrate how pass control could be implemented in two of the common Test Set operating configurations:

1. Test Set controlled by an external controller, and
2. Test Set running an IBASIC program with an external Controller connected to HP-IB bus.

### **Passing Control While the Test Set is Controlled by an External Controller**

This example illustrates passing control between the Test Set and an external controller while the Test Set is being controlled by the external controller. In this mode the Test Set is NOT configured as the System Controller. Generally speaking, in this mode of operation the Test Set is considered just another device on the HP-IB bus and its Controller capabilities are not used. However, it may be desirable, under certain conditions, to print a Test Set screen to the HP-IB printer for documentation or program debugging purposes. With manual intervention it is possible to have the Active Controller pass control to the Test Set, have the operator select and print the desired screen, and then pass control back to the formerly Active Controller. The following steps outline a procedure for accomplishing this task. The example is based upon having an HP 9000 Series 300 Workstation as the external controller connected to the Test Set through the HP-IB bus. Further, it assumes that the HP-IB interface in the HP 9000 Controller is set to the default select code of 7 and address of 21.

1. If a program is running on the HP 9000 Workstation, PAUSE the program.
2. Put the Test Set in local mode (press the LOCAL key on the front panel).
3. Configure the Test Set to print to the HP-IB printer using the PRINTER CONFIGURE screen.
4. Configure the Test Set to display the screen to be printed.



5. From the keyboard of the HP 9000 Workstation type in and execute the following command:

**Example**

```
OUTPUT 714; "*PCB 21"
```

This command tells the Test Set the address of the Controller to pass control back to.

6. From the keyboard of the HP 9000 Workstation type in and execute the following command:

**Example**

```
PASS CONTROL 714
```

This command passes control to the Test Set.

7. Put the Test Set in local mode (press the LOCAL key on the front panel).
8. Press SHIFT , then TESTS on the front panel of the Test Set to print the screen.
9. After the Test Set finishes printing the screen it will automatically pass control back to the HP 9000 Workstation.

### Passing Control Between an External Controller and the Test Set with an IBASIC Program Running.

The following example program illustrates the passing of control between an external Controller and the Test Set while an IBASIC program is running in the Test Set. The example is based upon having an HP 9000 Series 300 Workstation as the external controller connected to the Test Set through the HP-IB bus. Further, it is based on the assumption that the HP-IB interface in the HP 9000 Controller is set to the default select code of 7 and address of 21. In this example, the Test Set is NOT configured as the System Controller. This example illustrates the situation where the External Controller would perform the functions listed below.

1. Sends commands to the Test Set to cause a program to be loaded off of a Memory Card which is in the Test Set's front panel Memory Card slot.
2. Sends commands to the Test Set to run the program just loaded.
3. Passes control to the Test Set and then does other work while the Test Set is making measurements.

When the Test Set is finished making measurements and has data available for the External Controller, it passes control back to the External Controller.

4. The External Controller then requests the data from the Test Set.

The following program would run in the External Controller:

#### Example

```
10 COM /Hplib_names/ INTEGER Internal_hplib,Inst_address,Cntrl_state
20 COM /Cntrl_names/ Ext_cntrl_addrs,Int_cntrl_addrs
30 COM /Io_names/ INTEGER Printer_addrs,Pwr_suply_addrs
40 COM /Io_values/ REAL Meas_power,Prog_state${80},Prog_name${50}
50 COM /Reg_vals/ INTEGER Status_byte,Stdevnt_reg_val
60 !
70 Internal_hplib=7
80 Ext_cntrl_addrs=14
90 Int_cntrl_addrs=21
100 Printer_addrs=1
110 Pwr_suply_addrs=26
120 Inst_address=(Internal_hplib*100)+Ext_cntrl_addrs
130 Prog_name$="PASCTLEX:INTERNAL,4"
140 !
150 PRINTER IS CRT
160 !
170 ! Set the Controller up to respond to an SRQ from Test Set
180 ! The interrupt is generated by the Request Control bit in the Test Set
190 ON INTR Internal_hplib CALL Pass_control
200 ENABLE INTR Internal_hplib;2
210 !
220 ! Bring Test Set to known state.
230 OUTPUT Inst_address;"*RST"
240 !
250 ! Set the Test Set to cause SRQ interrupt on Request Control
260 OUTPUT Inst_address;"*CLS"
270 OUTPUT Inst_address;"*ESE 2"
280 OUTPUT Inst_address;"*SRE 32"
290 !
300 ! Load the desired program into the Test Set from Memory Card
```

```

305 OUTPUT Inst_address;"DISP TIB" ! Display the IBASIC screen
310 OUTPUT Inst_address;"PROG:EXEC 'DISP ""&"Loading program."&""""
320 OUTPUT Inst_address;"PROG:EXEC 'GET ""&Prog_name$&""""
330 OUTPUT Inst_address;"PROG:EXEC 'DISP ""&""&""""
340 !
350 ! Run the program in the Test Set
360 OUTPUT Inst_address;"PROG:EXEC 'RUN'"
370 !
380 REPEAT
390   STATUS Internal_hpib,3;Cntrl_state
400   DISP "WAITING TO PASS CONTROL TO THE Test Set."
410 UNTIL NOT BIT(Cntrl_state,6)
420 !
430 REPEAT
440   STATUS Internal_hpib,3;Cntrl_state
450   DISP "WAITING FOR CONTROL BACK FROM THE Test Set"
460 UNTIL BIT(Cntrl_state,6)
470 !
480 ! Data is ready in the Test Set
490 OUTPUT Inst_address;"PROG:NUMB? Meas_power"
500 ENTER Inst_address;Meas_power
510 PRINT "Measured power = ";Meas_power
520 !
530 DISP "Program finished."
540 END
550 !
560 SUB Pass_control
570 !
580   COM /Hpib_names/ INTEGER Internal_hpib,Inst_address,Cntrl_state
590   COM /Cntrl_names/ Ext_cntrl_addrs,Int_cntrl_addrs
600   COM /Io_names/ INTEGER Printer_addrs,Pwr_suply_addrs
610   COM /Io_values/ REAL Meas_power,Prog_state${80},Prog_name${50}
620   COM /Reg_vals/ INTEGER Status_byte,Stdevnt_reg_val
630 !
640   OFF INTR Internal_hpib
650   Status_byte=SPOLL(Inst_address)
660   IF NOT BIT(Status_byte,5) THEN
670     PRINT "SRQ for unknown reason. Status Byte = ";Status_byte
680     STOP
690   END IF
700 !
710 ! Tell Test Set where to pass control back to
720 OUTPUT Inst_address;"*PCB";Int_cntrl_addrs
730 !
740 ! Put Test Set in LOCAL mode so front panel keys function
750 LOCAL Inst_address
760 !
770 PASS CONTROL Inst_address
780 !
790   ENABLE INTR Internal_hpib;2
800 !
810 SUBEND

```

The following IBASIC program would be loaded off the PC card and run in the Test Set:

**Example**

```
10     COM /Hpib_names/ INTEGER Internal_hpib,External_hpib
20     COM /Cntrl_names/ Ext_cntrl_addrs,Int_cntrl_addrs
30     COM /Io_names/ INTEGER Printer_addrs,Pwr_suply_addrs
40     COM /Io_values/ REAL Meas_power
50     !
60     Internal_hpib=800
70     External_hpib=700
80     Ext_cntrl_addrs=21
90     Int_cntrl_addrs=14
100    Printer_addrs=1
110    Pwr_suply_addrs=26
120    !
130    OUTPUT Internal_hpib;"*RST"
140    CLEAR SCREEN
150    PRINTER IS CRT
160    !
170    EXECUTE ("REQUEST_CONTROL")
180    !
190    Try_again:  !
200    ON ERROR GOTO Not_active_cntrl
210    DISP "WAITING TO GET CONTROL"
220    OUTPUT External_hpib;" " !If OUTPUT successful then Active Controller
230    !If OUTPUT not successful then not Active Controller
240    DISP "TEST SET NOW ACTIVE CONTROLLER."
250    CALL Start_program
260    !
270    Pass_back: !
280    DISP "PASSING CONTROL BACK"
290    !Control is passed back automatically when the program stops
300    !Control is passed back to address specified by *PCB command
310    DISP "PROGRAM FINISHED"
320    STOP
330    !
340    Not_active_cntrl:  !
350    OFF ERROR
360    DISP "CHECKING FOR ERROR"
370    IF ERRN=173 THEN
380    GOTO Try_again
390    ELSE
400    PRINT "ERROR =" ;ERRN
410    STOP
420    END IF
430    !
440    END
450    !
460    SUB Start_program
470    !
480    COM /Hpib_names/ INTEGER Internal_hpib,External_hpib
490    COM /Cntrl_names/ Ext_cntrl_addrs,Int_cntrl_addrs
500    COM /Io_names/ INTEGER Printer_addrs,Pwr_suply_addrs
510    COM /Io_values/ REAL Meas_power
520    !
530    PRINT "SETTING POWER SUPPLY"
540    OUTPUT External_hpib+Pwr_suply_addrs;"IMAX 8;ISET 5"
550    OUTPUT External_hpib+Pwr_suply_addrs;"VMAX 15;VSET 13.2"
560    !
570    PRINT "SETTING UP INTERNAL INSTRUMENTS"
580    OUTPUT Internal_hpib;"RFG:FREQ 850.030 MHZ;AMPL -40 dBm"
590    OUTPUT Internal_hpib;"AFG1:FREQ 3 KHZ;DEST 'FM';FM 3 KHZ"
600    OUTPUT Internal_hpib;"DISP TX;MEAS:RFR:POW?"
610    ENTER Internal_hpib;Meas_power
620    !
630    OUTPUT External_hpib+Printer_addrs;"Measured power = ";Meas_power
640    !
650    OUTPUT External_hpib+Pwr_suply_addrs;"VSET 0"
660    !
670    SUBEND
```

---

# 7

## Memory Cards/Mass Storage

This chapter contains information about using the mass storage devices available in the Test Set for storing and retrieving program and data files. Access to the mass storage devices in the Test Set was designed primarily for the built-in IBASIC Controller. The Test Set's mass storage devices are not directly accessible by an external controller. The programming examples used in this chapter apply only to the Test Set's built-in IBASIC Controller.

---

### NOTE

Indirect access to the Test Set's mass storage devices is available through the PROGRAM:EXECute command. Refer to the *Standard Commands for Programmable Instruments (SCPI)* for generic information on the PROGRAM:EXECute command.

The IBASIC programming examples are provided to assist the programmer in understanding the use of the Test Set's mass storage devices. They are not intended to be a comprehensive description of the IBASIC mass storage commands and procedures. For detailed information on IBASIC commands, refer to the *HP Instrument BASIC User's Handbook*.

---

## Default File System

The Test Set's default file system is DOS (the Microsoft Disk Operating System MS-DOS<sup>®1</sup>).

---

## Mass Storage Device Overview

There are four types of mass storage devices in the Test Set (see [Figure 7-1 on page 199](#)):

1. Random-access memory (RAM) located on the Test Set's internal memory board
2. Read-only memory (ROM) located on the Test Set's internal memory board
3. Static random-access memory (SRAM) PC cards which are inserted into the Test Set's front-panel card slot
4. Read-only memory (ROM) PC cards (also called One-Time Programmable or OTP cards) which are inserted into the Test Set's front-panel card slot

---

### NOTE

The hardware for reading-from and writing-to PC cards is located internal to the Test Set. Therefore, the PC cards and the read-only memory (ROM) cards are considered internal to the Test Set even though the physical media must be inserted into the Test Set's front-panel card slot.

---

---

1. MS-DOS is a U.S. registered trademark of Microsoft Corporation.

**Figure 7-1**      **Mass Storage Devices**

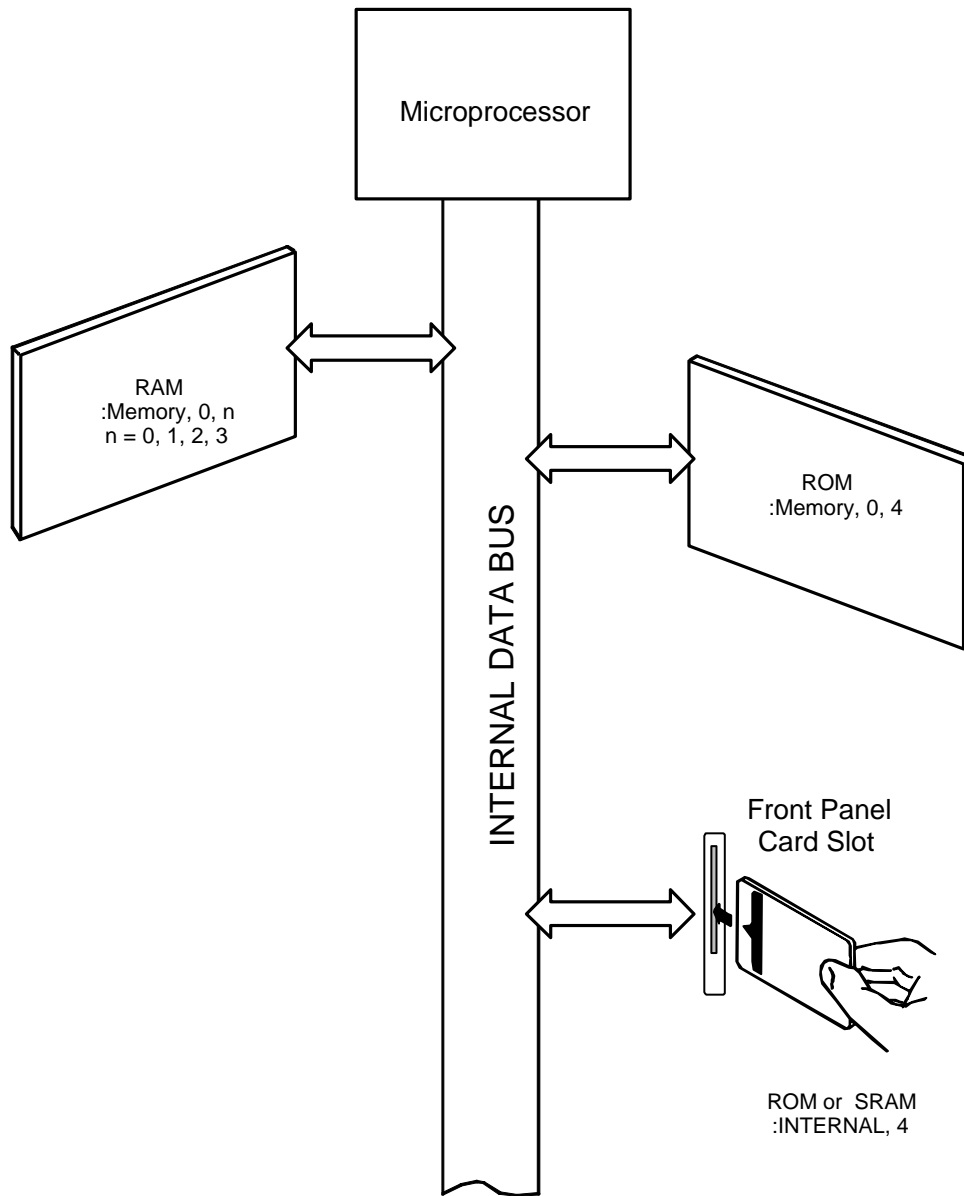

ch5drw01.drw

Programs and data can be retrieved from any of these mass storage devices. Programs and data can only be stored to RAM or SRAM PC card mass storage devices.

**Table 7-1 RAM Mass Storage Overview Typical Uses**

<b>Mass Storage Type</b>	<b>Physical Location</b>	<b>Mass Storage Volume Specifier</b>	<b>Media Type</b>
Non-volatile random access memory	Test Set's internal memory board	":MEMORY,0,unit number" unit number = 0, 1, 2, or 3 default = 0	N/A

- Temporary program and data storage
- Temporary Save/Recall register storage

Comments

- Easily overwritten or erased
- Not recommended for permanent program or data storage
- Unit 0 can be overwritten by the RAM\_MANAGER utility (IB\_UTIL) program (in ROM)
- Unit 1 can be overwritten by the COPY\_PL utility (IB\_UTIL) program (ROM)
- Units 2 and 3 are not overwritten by any ROM utility program

**Table 7-2 ROM Mass Storage Overview**

<b>Mass Storage Type</b>	<b>Physical Location</b>	<b>Mass Storage Volume Specifier</b>	<b>Media Type</b>
Read-only memory	Test Set's internal memory board	":MEMORY,0,4"	N/A

Typical Uses

- Permanent storage of factory supplied utility programs
- Permanent storage of factory supplied diagnostic programs

Comments

- Non-erasable
- Not available for user program or data storage
- Not available for Save/Recall register storage



**Table 7-3 PC Card Mass Storage Overview Typical Uses**

<b>Mass Storage Type</b>	<b>Physical Location</b>	<b>Mass Storage Volume Specifier</b>	<b>Media Type</b>
Static Random-Access Memory Card	Plugs into card slot on front panel of Test Set	":INTERNAL,4"	PC Card (such as PCMCIA)

- Semi-permanent program and data storage
- Semi-permanent Save/Recall register storage

Comments

- Low capacity
- Contents retained by on-card lithium battery
- Contents lost if on-card battery removed while card not in Test Set Memory Card slot
- Recommended as primary mass storage device for program and data storage

**Table 7-4 ROM Card Mass Storage Overview Typical Uses**

<b>Mass Storage Type</b>	<b>Physical Location</b>	<b>Mass Storage Volume Specifier</b>	<b>Media Type</b>
Read-only or OTP Memory Card	Plugs into card slot on front panel of Test Set	":INTERNAL,4"	PC Card (such as PCMCIA)

- Permanent storage of factory supplied application programs
- Permanent storage of factory supplied utility programs
- Permanent storage of factory supplied diagnostic programs

Comments

- Non-erasable
- Not available for user program or data storage
- Not available for Save/Recall register storage

## Default Mass Storage Locations

### Built-in IBASIC Controller

Under the following conditions, the default mass storage location for the built-in IBASIC Controller is the front-panel card slot (mass storage volume specifier ":INTERNAL,4"):

- power-up
- initializing RAM with the SERVICE screen's RAM Initialize function
- formatting an SRAM card using the I/O CONFIGURE screen's PCMCIA, Format Card field

The mass storage location for the built-in IBASIC Controller can be changed using the Mass Storage Is (MSI) command. Refer to the *HP Instrument BASIC Users Handbook* for further information on the MSI command.

### Save/Recall Registers

Under the following conditions, the default mass storage location for the save/recall registers is the Test Set's internal RAM (no mass storage volume specifier):

- power-up
- initializing RAM with the SERVICE screen's RAM Initialize function
- resetting the Test Set using the front-panel PRESET key
- resetting the Test Set using the \*RST HP-IB Common Command

The mass storage location for save/recall registers can be changed using the Save/Recall field in the I/O CONFIGURE screen. The default mass storage volume specifiers for the save/recall register mass storage locations are as follows:

- Internal selection - (no mass storage volume specifier, registers are saved to allocated RAM space)
- Card selection (not changeable) - ":INTERNAL,4"
- RAM selection (not changeable) - ":MEMORY,0,0" (See "Using RAM" on page 217.)

## Tests Subsystem

The default mass storage location for the Tests Subsystem is set using the `Select Procedure Location:` field on the SOFTWARE MENU screen. The default mass storage volume specifiers for the Tests Subsystem mass storage locations are as follows:

- Card selection (not changeable) - `":INTERNAL,4"`
- ROM selection (not changeable) - `":MEMORY,0,4"`
- RAM selection (not changeable) - `":MEMORY,0,0"`

## Selecting the Mass Storage Location

The IBASIC mass storage location is selected using the IBASIC Mass Storage Is command. The mass storage volume specifier for the desired mass storage location is appended to the Mass Storage Is command. Refer to the *HP Instrument BASIC User's Handbook* for further information regarding the Mass Storage Is (MSI) command.

For example, to change the default mass storage location to RAM unit 2, execute the following command:

```
MSI ":MEMORY,0,2"
```

The Mass Storage Is command is keyboard and program executable; however, any changes made are lost when the Test Set is turned off or when the SERVICE screen's `RAM Initialize` function is executed.

## Mass Storage Access

Program and data files stored on the Test Set's various mass storage locations can be selectively accessed from the following screens:

- The TESTS (IBASIC Controller) screen.

Any type of file can be accessed from this screen, either through an IBASIC program or the IBASIC command line.

- The SOFTWARE MENU screen using the `Select Procedure Location:` and `Select Procedure Filename:` fields.

Only *procedure* files shipped with HP software or procedure files created using the TESTS (Save/Delete Procedure) screen of the Tests Subsystem can be accessed using these fields. When created, procedure file names must include the *.PRC* extension (FM\_TEST.PRC).

A corresponding *code* file with the extension *.PGM* (FM\_TEST.PGM) must reside on the same media for the procedure to work.

- The TESTS (Save/Delete Procedure) screen using the `Select Procedure Location:` and `Enter Procedure Filename:` fields.

This screen is used to create "procedure" files. When created, procedure file names must include the *.PRC* extension (FM\_TEST.PRC).

Save/Recall register files, stored on the Test Set's various mass storage locations, can be accessed using the front-panel SAVE and RECALL keys.

## DOS File System Considerations

The DOS file system is used on IBM compatible personal computers. The DOS file system is hierarchical, which means it supports subdirectories. The DOS file system allows up to 8-character file names with an optional extension of up to 3 characters. The file name is separated from the extension (if it exists) with a period (.). DOS file names are case independent. The characters are stored as upper case ASCII in the DOS directory but the files may be referenced without regard to case. The DOS file system always converts any lowercase characters to uppercase when files are stored. For example, the file names File1 , FILE1 , file1 and FiLe1 all represent the single DOS file, FILE1.

Program and data files can be stored and retrieved from IBASIC using the DOS file system.

The period (.) may appear in the name but only to separate the file name from the extension. The period is not considered part of the file name itself. If the name portion of a DOS file name is longer than 8 characters, it is truncated to 8 characters and no error is generated. Similarly, if the extension is longer than 3 characters, it is truncated to 3 characters and no error is given.

## Test Set File Naming Conventions

The Test Set's Tests Subsystem uses the following file naming conventions:

- The *.PGM* extension is used to indicate a code file and is automatically added to the file name when the program code file is stored for use by the Tests Subsystem.
- The *.PRC* extension is used to indicate a procedure file and is added to the file name when the file is stored by the Tests Subsystem
- The *.LIB* extension is used to indicate a library file and is added to the file name when the file is created by the Program Development System for use with the Tests Subsystem

The Test Set's Save/Recall register subsystem uses the following file naming convention:

- The *.SAV* extension is used to indicate a stored Save/Recall register file and is added to the file name when the file is created.

## Potential File Name Conflicts

Unexpected file operation can occur if proper consideration is not given to the different file system naming conventions and the Test Set file entry field width.

- A full DOS file name is 12 characters (8 character file name + . + 3 character extension). A full DOS file name will not fit in the Test Set's file entry field.
- Any file with a *.PGM* extension is considered a Tests Subsystem code file. If the Tests Subsystem attempts to retrieve a file which is not a code file, the following error will be generated: `Error reading code file. Check file and media.`
- Any file with a *.PRC* extension is considered a Tests Subsystem procedure file. If the Tests Subsystem attempts to retrieve a file which is not a procedure file, the following error will be generated: `Error reading procedure file. Check file and media.`
- Any file with a *.LIB* extension is considered a Tests Subsystem library file. If the Tests Subsystem attempts to retrieve a file which is not a library file, the following error will be generated: `Error reading library file. Check file and media.`
- When reading files from mass storage, the Test Set interprets the "." (period) as a delimiter and ignores any following characters. File extensions will be stripped off by the Test Set before displaying the filename in the file list. This could result in `Error 54 Duplicate File Name.`
- When reading files from mass storage, the Test Set truncates filenames with more than 8 characters. This could result in `Error 54 Duplicate File Name.`
- When storing or deleting files, the file name is silently truncated to 8 characters since DOS only allows 8-character file names. This could result in `ERROR 54 Duplicate File Name.`

## File Naming Recommendations

The following naming conventions are recommended.

- Ensure that only Tests Subsystem *procedure* files use the *.PRC* extension.
- Ensure that only Tests Subsystem *library* files use the *.LIB* extension..
- Ensure that only Tests Subsystem *code* files use the *.PGM* extension..
- Ensure that only *Save/Recall* register files use the *.SAV* extension..

## Initializing Media

The INITIALIZE command is used to initialize a media (PC card, and RAM).

## Test Set File Types

The Test Set's file system supports the following file types:

- ASCII - files containing ASCII characters
- BDAT - files containing binary data
- DIR - DOS subdirectories
- DOS - saved code files

## Using the ROM

The Test Set comes with several Test Procedures stored on the internal ROM. These Test procedures provide instrument diagnostic utilities, periodic calibration utilities, memory management utilities, a variety of general purpose utilities, and several IBASIC demonstration programs.

To see a brief description of what each procedure does perform the following steps:

1. Display the SOFTWARE MENU screen by selecting the front-panel TESTS key.
2. Use the cursor control knob to select the `Select Procedure Location:` field and choose ROM from the choices.
3. Select the `Select Procedure Filename` field. A list of Test Procedures stored on the ROM is displayed in the `Choices:` field. Select a procedure.

A brief description of the Test Procedure will be displayed in the `Description` field.

ROM cannot be written to for user storage.

The ROM's mass storage volume specifier is `":MEMORY,0,4"`

For example: to catalogue the contents of the ROM from the TESTS (IBASIC Controller) screen enter:

### Example

```
CAT ":MEMORY,0,4"
```



## Using PC Cards

OTP (One-Time Programmable) cards provide removable read-only storage. File editing and erasure are not possible. These cards cannot be programmed by the Test Set; they require a special PC card programmer to save files.

PC cards (SRAM) provide removable read/write memory for your files, similar to a flexible disk. Data can be stored, re-stored, read, or erased as needed.

PC cards require a battery to maintain stored information.

**Table 7-5**

**PC Card Part Numbers**

<b>Memory</b>	<b>Type</b>	<b>Part Number</b>
1 Megabyte	SRAM	HP83231A (0950-2635)
64 kilobytes	SRAM	HP 83230A (0950-2634)
256 kilobytes	SRAM	HP 83233A (0950-2640)

## Inserting and Removing Memory Cards

Figure 7-2 illustrates how to insert a PC card into the Test Set's front panel. To remove a PC card, simply pull it out.

The Test Set's memory-card label is marked with "INSERTION END" and an arrow that must be inserted face-up in the slot.

---

**NOTE**

Memory cards may be inserted and removed with the Test Set powered on or off.

---

**Figure 7-2**      **Inserting a Memory Card**

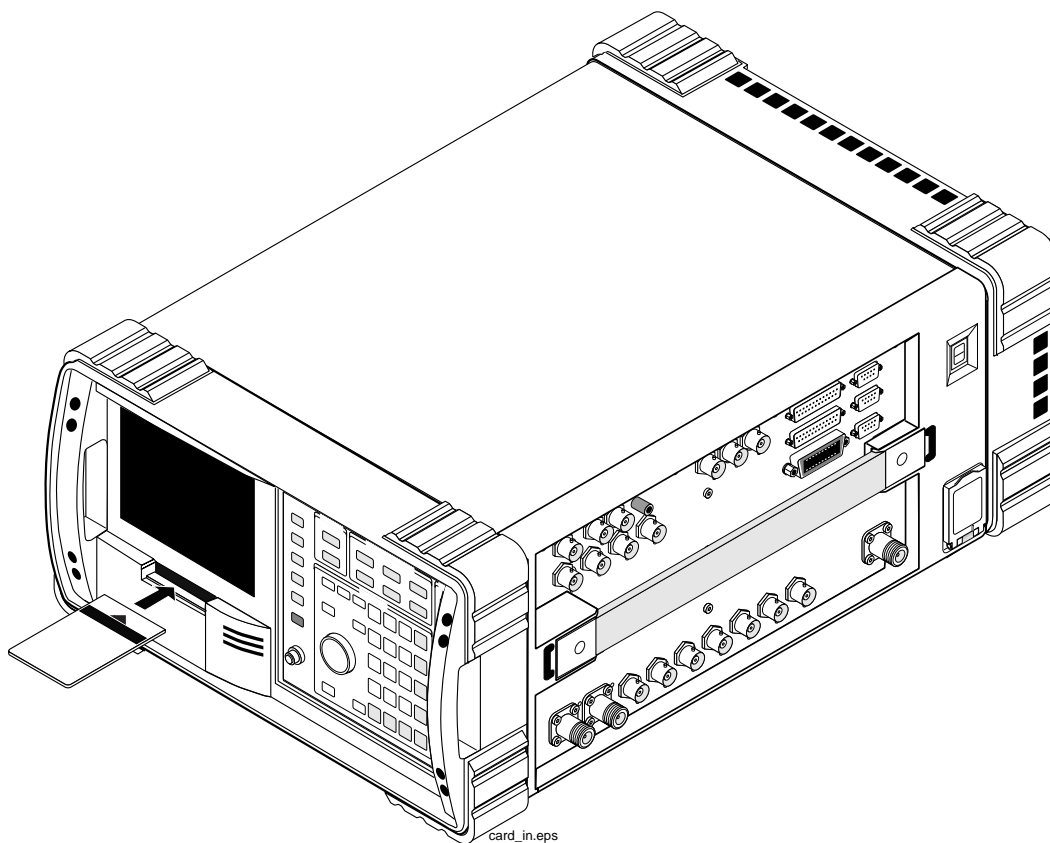

## Setting the Write-Protect Switch

The SRAM PC card's write-protect switch lets the user secure its contents from being overwritten or erased. The switch has two positions (see [Figure 7-3](#)):

- *Read-write* – The memory-card contents can be changed or erased, and new files may written on the card.
- *Read-only* – The memory-card contents can be read by the Test Set, but cannot be changed or erased.

**Figure 7-3**      **Inserting the Battery and Setting the Write-Protect Switch**

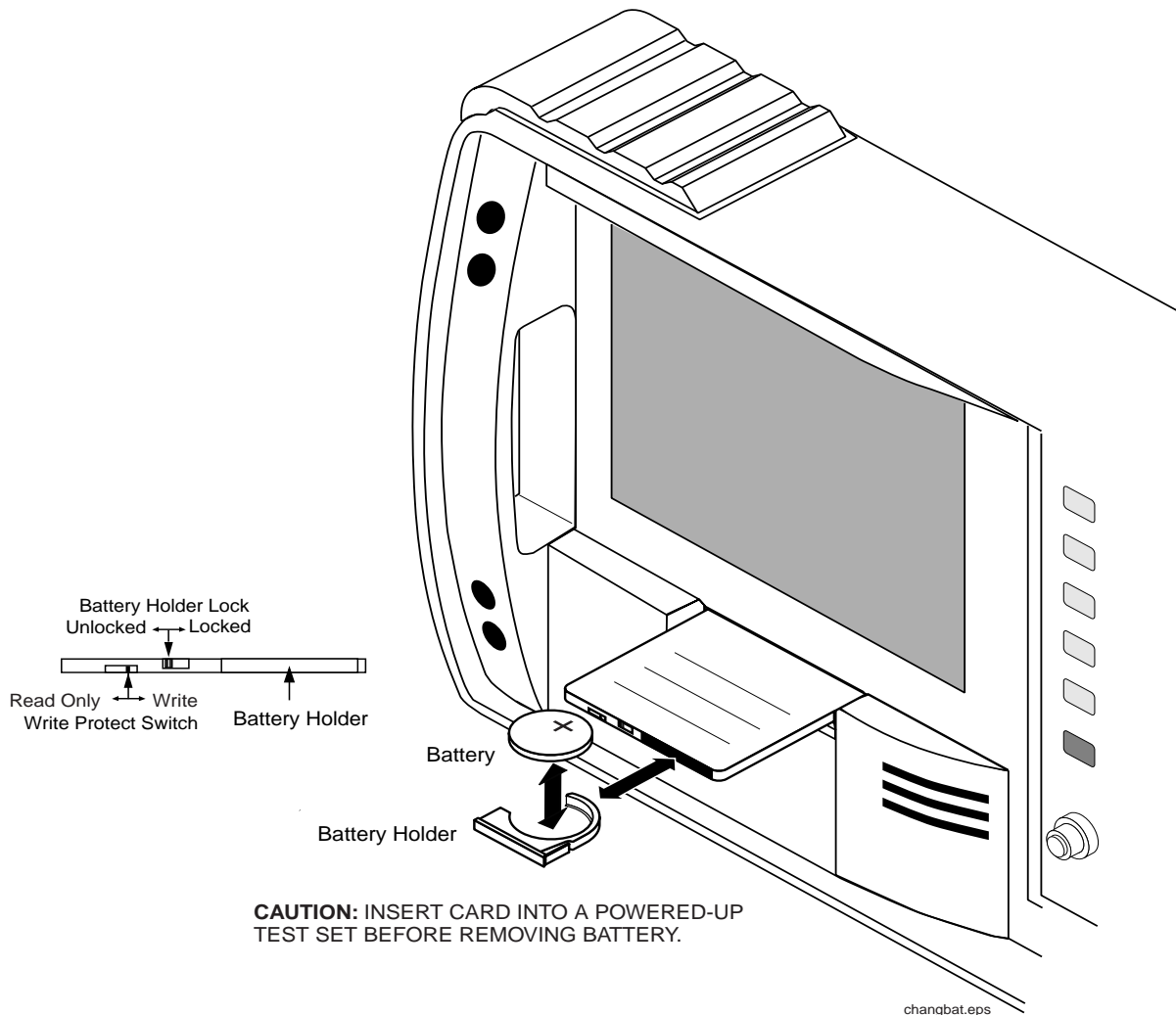

## The Memory Card Battery

SRAM PC cards use a lithium battery to power the card. Listed below are the batteries for the Test Set's SRAM cards. SRAM cards typically retain data for over 1 year at 25° C. To retain data, the battery should be replaced annually.

SRAM Card Battery Part Numbers - CR2025 or HP 1420-0509

### Replacing the Battery

1. Turn the Test Set on and insert the PC card. An inserted PC card takes power from the Test Set, preventing the card's contents from being lost.

---

#### CAUTION

---

If you remove the PC card's battery when the card is not installed in the Test Set, the contents of the card will be lost.

2. Hold the PC card in the slot with one hand and pull the battery holder out with your other hand. (See [Figure 7-3 on page 211](#).)
3. Install the battery with the side marked "+" on the same side marked "+" on the battery holder. Avoid touching the flat sides of the battery, finger oils may contaminate battery contacts in the memory-card.
4. Re-insert the battery holder into the PC card.

---

#### WARNING

---

**Do not mutilate, puncture, or dispose of batteries in fire. The batteries can burst or explode, releasing hazardous chemicals. Discard unused batteries according to the manufacturer's instructions.**

## Memory Card Mass Storage Volume Specifier

The front-panel PC card slot's mass storage volume specifier is ":INTERNAL,4" and is the default mass storage device for the Test Set. For example, to catalogue the contents of a PC card from the TESTS (IBASIC Controller) screen, execute the following IBASIC command:

Example

```
CAT ":INTERNAL,4"
```

or, if the mass storage location has not been changed,

Example

```
CAT
```

If the MSI (Mass Storage Is) command has been used to change the mass storage location to a different device, the ":INTERNAL,4" designation must be used to access the PC card slot. Any changes to the mass storage location made with the MSI (Mass Storage Is) command are lost when the Test Set is turned off.

## Memory Cards and Initialization

There are several types of PC cards available, and the following cards are used with the Test Set:

- SRAM: used for Save/Recall and data storage
- Flash ROM: used when upgrading firmware
- OTP (One Time Programmable): used for HP software

Flash ROM cannot be used for collecting data and Save/Recall.

Data cannot be saved to Flash ROM and OTP cards with the Test Set's PC card slot. SRAM can be initialized with the Test Set.

### Initializing SRAM Cards for Save/Recall and Data Collection

1. Insert the SRAM card into the slot. If the card is uninitialized, a message will appear at the top of the display.
2. Press **Shift** and **IO Config** to display the I/O CONFIGURE screen.
3. Using the knob, locate the **FORMAT CARD** field.
4. Select the **PCMCIA Format Card** field. A prompt will appear at the top of the display. Pressing **Yes** will erase and initialize the card.

## Backing Up Procedure and Library Files

Making a backup copy of procedure and library files helps guard against file loss due to PC card (or battery) failure.

### Using the COPY\_PL ROM Program

The COPY\_PL procedure on the internal ROM will make backup copies of Tests Subsystem's Procedure and Library files onto a second SRAM PC card, and can also initialize an uninitialized PC card. This program does not make backup copies of Tests Subsystem's code files, or copy any type of file to OTP cards.

The COPY\_PL procedure is designed for use with HP software to make backup copies of Hewlett-Packard supplied, or user-generated procedure and library files.

To run COPY\_PL:

1. Access the SOFTWARE MENU screen.
2. Select the `Select Procedure Location:` field and choose ROM.
3. Select the `Select Procedure Filename:` field and select IB\_UTIL.
4. Select the `Run Test` softkey to start the procedure.
5. Select COPY\_PL from the list of utilities.
6. Follow the displayed instructions.

## Copying Files Using IBASIC Commands

Files can be copied from one mass storage device to another using the IBASIC COPY command. For example, to copy a file from a PC card to the Test Set's internal RAM, execute the following IBASIC command from the TESTS (IBASIC Controller) command line:

### Example

```
COPY "FM_TEST:INTERNAL,4" TO "FM_TEST:MEMORY,0"
```

Files on one PC card can be copied to another PC card as follows:

- Insert the PC card containing the file to be copied.
- LOAD the desired file from the PC card into the Test Set.
- Remove the original PC card.
- Insert the destination PC card in the Test Set.
- SAVE the file to the destination PC card.

## Copying an Entire Volume

An entire volume can be copied from one mass storage device to the same type of mass storage device using the volume copy form of the COPY command. The destination volume must be as large as, or larger than, the source's volume. The directory and any files on the destination volume are destroyed. The directory size on the destination volume becomes the same size as the source media. Disc-to-disc copy time is dependent on the mass storage device type. The volume copy form of the COPY command was designed to copy like-media to like-media and like-file-systems to like-file-systems. For example, to copy the entire contents of one internal RAM volume to another internal RAM volume, execute the following IBASIC command from the TESTS (IBASIC Controller) command line:

### Example

```
COPY ":MEMORY,0,0" TO ":MEMORY,0,1"
```

---

### NOTE

Caution should be exercised when using the volume copy form of the COPY command. Using the volume copy form of the COPY command can produce unexpected results. All files on the floppy disk before the volume copy was executed will be lost and *are not recoverable*.

The Test Set only supports one type of volume copy using the COPY command: like-media to like-media (RAM to RAM, card to card, and so forth).

All other types of volume copy are unsupported and will produce unexpected results or system errors.

---

Using wildcards in the COPY command can eliminate the need to use the volume form of the COPY command. Refer to the *HP Instrument BASIC User's Handbook* for further information on wildcards and their use in the COPY command.



---

## Using RAM

RAM is a section of the Test Set's internal RAM that has been set aside for use as a mass storage device. RAM acts much the same as an external disk drive; that is, program and data files can be stored, re-stored, erased, and retrieved from the RAM.

The RAM is partitioned into four separate volumes: 0-3. Each volume is treated as a separate "disk." The size of each volume can be specified in 256-byte increments.

The four RAM volumes are designated ":MEMORY,0,0" to ":MEMORY,0,3". For example, to catalog the contents of RAM volume 0 from the TESTS (IBASIC Controller) screen, execute the following command:

### Example

```
CAT ":MEMORY,0,0"
```

Volume 0's contents can be viewed and loaded from the TESTS (IBASIC Controller) screen, the SOFTWARE MENU screen, the TESTS (Save/Delete Procedure) screen. Volumes 1, 2, and 3 can only be accessed from the TESTS (IBASIC Controller) screen.

---

### NOTE

#### RAM Erasure.

The contents of RAM are easily lost. Volume 0 can be overwritten by the RAM\_MANAGER utility program. Volume 1 can be overwritten by the COPY\_PL utility program. (RAM\_MANAGER and COPY\_PL are found in the IB\_UTILS program in internal ROM.) The contents of all units are lost when the SERVICE screen's RAM Initialize function is executed. Therefore, RAM should only be used for non-permanent, short-term storage of program or data files.

---

## Initializing RAM

Each RAM volume must be initialized before it can be used.

- Volume 0 can be initialized using the RAM\_MANAGER in the IB\_UTIL internal ROM program.
- Volumes 1, 2, and 3 must be initialized from the TESTS (IBASIC Controller) screen.

The optional “unit size” parameter in the following procedure specifies the memory area, in 256 byte blocks, set aside for each disk volume.

Follow these steps to initialize volumes 1, 2, or 3:

1. Access the TESTS (IBASIC Controller) screen.
2. Using the cursor control knob or an external terminal, enter and execute the IBASIC command:

### Example

```
INITIALIZE ":MEMORY,0,<unit number 1-3>",<unit size>
```

For example:

### Example

```
INITIALIZE ":MEMORY,0,1",50
```

---

## **8** **IBASIC Controller**

## Introduction

The Test Set contains an instrument controller that can run programs to control the various instruments in the Test Set and instruments/devices connected to the Test Set's external I/O ports (HP-IB, serial, and parallel). Refer to [“Overview of the Test Set” on page 18](#) for a complete description of the Test Set's hardware architecture.

The instrument controller runs a subset of the Hewlett-Packard Rocky Mountain BASIC programming language called Instrument BASIC or IBASIC. Using this programming language it is possible to develop programs which use the Test Set's instruments to automatically test a variety of radios. Software is available from Hewlett-Packard, for testing the major radio systems currently in use today. Users can also develop their own IBASIC programs for automated radio testing.

This chapter is designed to provide the programmer with the information needed to develop IBASIC programs for use on the built-in IBASIC controller. Refer to the individual HP software manuals for information on using the IBASIC controller with Hewlett-Packard supplied software.

## The IBASIC Controller Screen

The Test Set has a dedicated screen for interfacing with the built-in IBASIC controller. This is the TESTS (IBASIC Controller) screen as shown in [Figure 8-1](#). This screen is accessed as follows:

1. Select the front panel **Menu** key. The SOFTWARE MENU screen will be displayed.
2. Using the rotary knob, position the cursor on the **IBASIC** field in the lower center of the screen.
3. Push the rotary knob and the TESTS (IBASIC Controller) screen will be displayed.

**Figure 8-1**      **The IBASIC Screen**

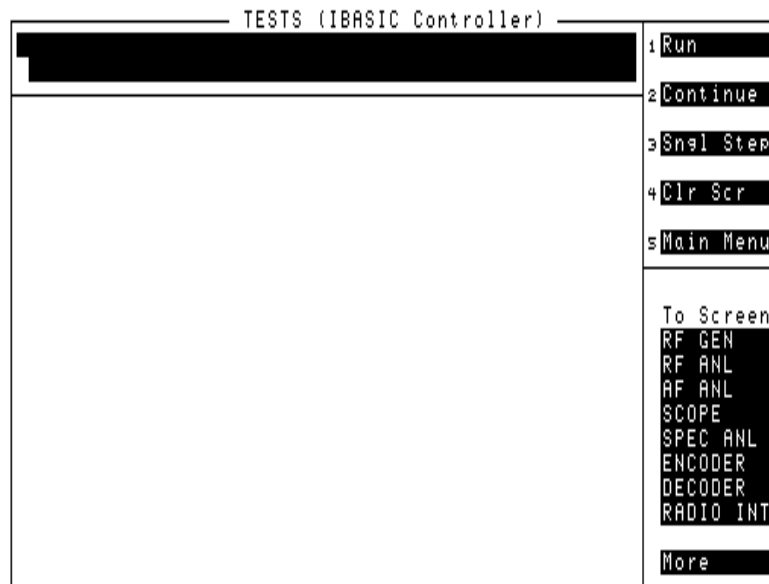

The TESTS (IBASIC Controller) screen can be accessed programmatically by sending the following command:

**Example**

```
OUTPUT 714;"DISP TIBasic"
```

The TESTS (IBASIC Controller) screen is divided into several areas which are used by the IBASIC controller for different purposes.

- The highlighted horizontal rectangle at the top is the IBASIC command line. As the name implies IBASIC commands can be executed from this line. Commands can be entered locally using the rotary knob or remotely using serial port 9. A maximum of 100 characters may be entered into the command line.
- The side of the display is the softkey label area. The five highlighted areas within the softkey label area correspond to the five USER keys on the front panel of the Test Set. IBASIC programs can assign tables to these keys and control program execution by using ON KEY interrupts.
- The area in the center of the screen is the display screen for the IBASIC controller. The IBASIC controller uses this area for, displaying alpha, numeric, and graphic information, program editing, program listing and so forth. This area operates as would the CRT on an external Hewlett-Packard 9000 Series 200/300 Workstation.

---

## Important Notes for Program Development

The Test Set is designed to operate the same way under automatic control as it does under manual control. This has several implications when designing and writing programs for the Test Set:

- To automate a particular task, determine how to do the task manually and then duplicate the steps in the program.
- In Manual Control mode, a Test Set function must be displayed and “active” to make a measurement or receive DUT data. Therefore, to make a measurement using an IBASIC program, follow these basic steps:
  1. Use the DISPlay command to select the screen for the instrument whose front panel contains the desired measurement result or data field (such as AF ANALYZER).
  2. Set the measurement field (such as SINAD) to the ON state.
  3. Trigger a reading.
  4. Read the result.

---

### NOTE

The following sections discuss developing IBASIC programs which do not use the TESTS Subsystem. Programs written for the TESTS Subsystem require the creation of supporting Library, Procedure, and Code files, and must be written using a specific program structure. The HP Test Software packages are examples of this type of program.

Refer to the [“Writing Programs For the TESTS Subsystem”](#) on page 288 for information on writing programs for the TESTS Subsystem.

---

## Program Development

There are three recommended approaches for developing IBASIC programs. They are outlined in [Figure 8-2](#) and discussed in more detail later in this chapter. Since the Test Set only has the rotary knob and numeric keypad for data/character entry, developing programs on the Test Set alone is not recommended. All three development methods employ an external computer or terminal. The choice of development method will typically be driven by available equipment and extent of development task. If the development task is large, it is strongly recommended that a BASIC language computer be used as outlined in development Method #1.

Method #2 is recommended for large program modification or smaller program development. Method #2 uses an external PC or terminal as the CRT and keyboard for the built-in IBASIC controller.

Method #3 is least preferred for program development or modification because no syntax checking occurs until the program is first run making it difficult to debug long programs. Details of each development method are given later in this chapter.



**Figure 8-2 Program Development Methods**

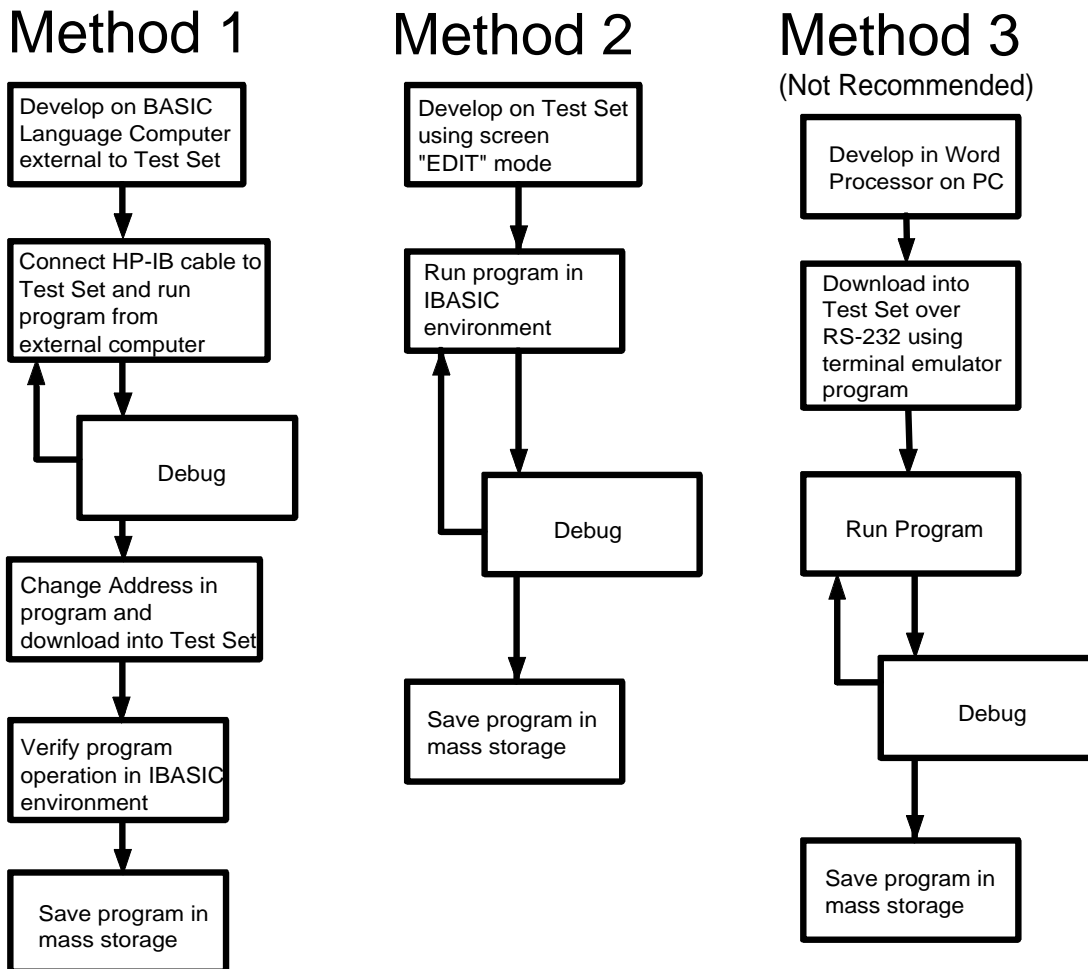

ch8drv2.drw

## Interfacing to the IBASIC Controller using Serial Ports

This section describes how to interconnect the Test Set to an external PC or terminal using the Test Set's serial I/O ports. Program development methods #2 and #3 use PC's or terminals connected to the Test Set through the Test Set's serial I/O ports. To determine which programming environment best fits your application, refer to [“Choosing Your Development Method” on page 238](#).

### Test Set Serial Port Configuration

To prepare for IBASIC program development, the Test Set must first be configured to operate with a PC or terminal.

This includes,

- Hardware
- Cables
- Screens - I/O CONFIGURE and TESTS (IBASIC Controller)

There are three independently controllable serial interfaces in the Test Set, each using a 3-wire transmit/receive/ground implementation of the RS232 standard. The IBASIC Controller can send and receive data from any of these ports by using its assigned select code.

#### Serial Port Information

The Test Set's RS232 ports are DB-9 connectors. The ports are wired as data terminal equipment (DTE). See [Figure 8-3](#) and [Table 8-1 on page 227](#).

**Serial Port 9.** Serial Port 9 is used for developing and editing IBASIC programs since it has direct access to the IBASIC Command Line field. It can also be used for data I/O from an IBASIC program. Settings can be changed from the I/O CONFIGURE screen, using IBASIC commands executed from the IBASIC Command Line field, or using IBASIC commands executed from an IBASIC program. If simultaneous multiple serial I/O is not a requirement, then use only serial port 9 because it can directly access the IBASIC Command Line field.

**Serial Ports 10 and 11.** Serial Ports 10 and 11 are primarily used for data I/O from an IBASIC program to a device-under-test- (DUT). Settings can be changed using IBASIC commands executed from the IBASIC Command Line field, or using IBASIC commands executed from an IBASIC program but not from the I/O CONFIGURE screen. Serial Port 10 can be connected to a serial printer for generating program listings or as the destination printer for the program.

**Figure 8-3**      **Serial Port Pin Assignments**

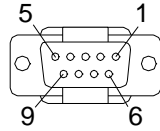

**Table 8-1**      **Serial Port Pin Assignments**

<b>Pin</b>	<b>Description</b>
1	CD - Carrier Detect
2	RD - Receive Data
3	TD - Transmit Data
4	DTR - Data Terminal Ready
5	Ground
6	DSR - Data Set Ready
7	RTS - Request to Send
8	CTS - Clear to Send
9	RI - Ring Indicator

## Serial Port 9 Configuration

Table 8-2 on page 229 and the following paragraphs describe how to configure Serial Port 9 for communications with an external PC or terminal. Implications of the various choices are discussed.

1. Under the `To Screen` menu, select `More`, then select `IO CONFIG`.
2. The `I/O CONFIGURE` screen will be displayed.
3. Set the `Serial Baud Rate`, `Parity`, `Data Length`, `Stop Length`, `Rcv Pace` and `Xmt Pace` fields to match your PC or terminal settings. The recommended settings are shown in Table 8-2 on page 229. These settings will be retained by the Test Set. They will not change if the `PRESET` key is pressed, if the Test Set receives a `*RST` Common Command, or the power is turned on and off.
4. Set the `Serial In` field to `Inst`. This routes Serial Port 9 to the `IBASIC Command Line` field. Characters typed on the external PC or terminal will now appear in the `IBASIC Command Line`.
5. Set the `IBASIC Echo` field to `ON`. This will cause IBASIC character output from commands (such as `LIST`, `PRINT` or `DISPLAY`) or error messages to echo characters to Serial Port 9 (the characters will in turn show up on the external PC or terminal screen). This will allow program listings and syntax error messages to be seen on the external PC or terminal.
6. Another method which can be used to output characters to the external PC or terminal is to execute the IBASIC command, `PRINTER IS 9`. This causes IBASIC to direct all print output to Select Code 9. Select Code 9 is the Test Set's Serial Port 9. Select Code 1 is the Test Set's CRT. Select Code 1 is also the default address for the `PRINTER IS` command, so all program printer output defaults to the Test Set's CRT (unless changed with the `PRINTER IS` command).
7. Set the `Inst Echo` field to `ON`. This will cause characters to be echoed back to the external PC or terminal as they are received at Serial Port 9. If the echo feature of the external PC or terminal is also enabled all the characters sent to the Test Set will be displayed twice on the external PC or terminal. Enable echo on only one device, either the Test Set or the external PC or terminal.

## Receive and Transmit Pacing

When receiving characters into the IBASIC Command Line field, the Test Set's microprocessor responds to each entry and no buffering is required. Therefore, when using your PC or terminal to send characters to the IBASIC Command Line field, it is permissible to set Rcv Pace and Xmt Pace to None.

When sending data through the Test Set's Serial Port to external devices like printers which may have small input buffers, it is important to set Rcv Pace and Xmt Pace to Xon/Xoff. This allows the printer to stop data transmission from the Test Set when the printer's buffer is full and then start it again when the printer is ready.

The Test Set has a Serial Port input buffer length of 2000 characters. Buffer size becomes important when IBASIC programs expect to receive large amounts of data through the Serial Port with a single ENTER statement.

**Table 8-2 Test Set Serial Port 9 Configuration**

Field	Available Settings	Recommended Setting
Serial In	Inst/IBASIC	Inst
IBASIC Echo	On/Off	On
Inst Echo	On/Off	On
Serial Baud Rate	150, 300, 600, 1200, 2400, 4800, 9600, 19200	9,600
Parity	None, Odd, Even, Always 1, Always 0	None
Data Length	7 bits, 8 bits	8 bits
Stop Length	1 bit, 2 bits	1 bit
Rcv Pace (receive pacing)	None, Xon/Xoff	Xon/Xoff
Xmt Pace (transmit pacing)	None, Xon/Xoff	Xon/Xoff

## PC Configuration

To prepare for IBASIC program development, the external PC or terminal must be configured to operate with the Test Set. This configuration includes

- Hardware
- Terminal Emulator Software

### PC Serial Port Configuration

Connect the Test Set's Serial Port 9 to a serial I/O (input/output) port on the PC. On many PCs, a serial port is available as either a 25-pin DB-25 (female) connector or a 9-pin DB-9 (male) connector. This port can be configured as COM1, COM2, COM3, or COM4 (communications port 1, 2, 3, or 4) depending on the installed PC hardware and user-defined setup. Refer to the instructions shipped with the PC for hardware and software configuration information.

### Terminal Emulator Configuration Information

A "terminal emulator" is an application program running on the PC that communicates with one of the serial communication ports installed in the PC. It provides a bi-directional means of sending and receiving ASCII characters to the Test Set's serial port.

In general, a "terminal emulator" enables the PC to act like a dedicated computer terminal. This type of terminal was used before PCs to allow remote users to communicate through RS232 with central mainframe computers. An ANSI-compatible terminal like the Digital Equipment Corporation VT-100 can be used to directly communicate with the Test Set. PC terminal emulation application programs have been designed to have setup fields much like these older technology terminals.

**Setting Up Microsoft Windows<sup>®</sup> Terminal on your PC (Windows Version 3.1).**

1. Start the Terminal program in Windows.
2. From the Terminal Menu select Settings then Emulation.
3. Select DEC VT-100 (ANSI)
4. From the Terminal Menu select Settings then Terminal Preferences
5. Edit the Terminal Preference settings to match the following
  - Terminal Modes
    - Line Wrap: Off
    - Local Echo: Off
    - Sound: Off
  - Columns: 132
  - CR->CR/LF
    - Inbound: Off
    - Outbound: Off
  - Cursor
    - Block
    - Blink: On
  - Terminal Font: Fixedsys
  - Translations: None
  - Show Scroll Bars: On
  - Buffer Lines: 100
  - Use Function, Arrow, and Ctrl Keys for Windows: Off
6. From the Terminal menu select Settings then Text Transfers.
7. Edit the Text Transfer settings to match the following.
  - Flow Control: Standard Flow Control
  - Word wrap Outgoing Text at Column: Off
8. From the Terminal menu select Settings then Communications

9. Edit the Communications settings to match those of the Test Set. An example setting is shown below.

- Baud Rate: 9600
- Data Bits: 8
- Stop Bits: 1
- Parity: None
- Flow Control: Xon/Xoff
- Connector: Com1 (be sure to match your current setup)
- Parity Check: Off
- Carrier Detect: Off



### **Setting Up ProComm<sup>1</sup> Revision 2.4.3 on your PC.**

ProComm is a general purpose telecommunications software package for PC's with MS-DOS. One of its functions is to provide an RS-232 terminal function on a typical PC.

**Running ProComm in MS-DOS.** (You can use ProComm's built-in help function to learn more about setting it up).

1. To access the help and command functions, press the Alt and F10 keys simultaneously (abbreviated as Alt+F10).
2. Press the space bar to move among the choices for a particular field.
3. Press ENTER to accept the displayed choice.

### **Setting up the ProComm Software.**

1. Press Alt+ P to access the LINE SETTINGS window.
2. Enter the number 11. This will automatically set the following:
  - Baud rate: 9600
  - Parity: None
  - Data Bits: 8
  - Stop Bits: 1
  - Selected communications port: COM1 (This may be different on your PC)
3. To select a different communications port, enter the following numbers:
  - 20: COM1
  - 21: COM2
  - 22: COM3
  - 23: COM4
4. Enter the number 24 to save changes, to make the new configuration your default, and to exit LINE SETTINGS.
5. Press Alt+S for the SETUP MENU.
6. Enter the number 1 for MODEM SETUP.
7. Enter the number 1 for the Modem init string.
8. Press Enter to set a null string.
9. Press Esc to exit MODEM SETUP back to the SETUP MENU.
10. Enter the number 2 for TERMINAL SETUP.

---

1. ProComm is a product of Data Storm Technologies.

11. Terminal emulation: VT-100

- Duplex: FULL
- Flow Control: XON/XOFF
- CR translation (in): CR
- CR translation (out): CR
- BS translation: NON-DEST
- BS key definition: BS
- Line wrap: ON
- Scroll: ON
- Break length (ms): 350
- Enquiry (CNTL-E): OFF

12. Press Esc to exit Terminal Setup back to the Setup Menu.

13. Enter the number 4 for General Setup.

- Translate Table: OFF
- Alarm sound: OFF
- Alarm time (secs): 1
- Aborted downloads: KEEP

14. Press Esc to exit General Setup back to the Setup Menu.

15. On the Setup Menu, press S to save your entries.

16. Press Esc to exit the Setup Menu.

17. Press Alt+X to exit ProComm back to MS-DOS.

### **Setting Up HP AdvanceLink (HP 68333F Version B.02.00) on your PC.**

HP AdvanceLink is a software program which allows PCs to be used as an alphanumeric or graphics terminal. It can also automate terminal and file-transfer functions. The version described will work with PCs with the MS-DOS or PC-DOS operating systems. (AdvanceLink for Windows is also available, and configuration is very similar).

#### **Running AdvanceLink in MSDOS.**

1. Press the Tab key to move from one field to the next, which also accepts the displayed choice.
2. Press the NEXT CHOICE and PREVIOUS CHOICE keys to move among the choices for a particular field.

#### **Setting up the AdvanceLink Software.**

1. Press the TERMINAL function key.
2. Press CONFIG KEYS.
3. Press GLOBAL CONFIG.
  - Keyboard: USASCII
  - Personality: ANSI
  - Language: ENGLISH
  - Terminal Mode: Alphanumeric
  - Remote To: enter your PC's selected serial port number, often, Serial 1
  - Printer I/F: None
  - Memory Size: 32K
  - Plotter I/F: None
  - Video Type: select your display type
  - Forms Path: no entry
  - Screen Size: select your size – 23 or 24
4. Press DONE to return to the Config screen.

5. Press REMOTE CONFIG (to set up the Serial port you selected above in Remote To).
  - Baud Rate: 9600
  - Parity/DataBits: None/8
  - Enq Ack: NO
  - Asterisk: OFF
  - Chk Parity: NO
  - SR(CH): LO
  - Recv Pace: Xon/Xoff
  - CS(CB)Xmit: NO
  - XmitPace: Xon/Xoff
6. Press DONE to return to the Config screen.
7. Press TERMINAL CONFIG.
  - Terminal Id: 2392A
  - LocalEcho: OFF
  - CapsLock: OFF
  - Start Col: 01
  - Bell: ON
  - XmitFnctn(A): NO
  - SPOW(B): NO
  - InhEolWrp(C): NO
  - Line/Page(D): LINE
  - InhHndShk(G): NO
  - Inh DC2(H): NO
  - Esc Xfer(N): YES
  - ASCII 8 Bits: YES
  - Fld Separator: down arrow or US
  - BlkTerminator: up arrow or RS
  - ReturnDef: musical note or CR
  - Copy: Fields
  - Type Ahead: NO
  - Row Size: 160
  - Host Prompt Character: left arrow or D1
  - Horiz. Scrolling Increment: 08
8. Press DONE to return to the Config screen.
9. Press DONE to return to the Terminal screen.
10. Press MAIN to return to the Main screen.
11. Press EXIT ADVLINK to exit.

## Terminal Configuration

Terminals typically have a DB-25 (male) connector. Set the terminal for DEC VT-100 ANSI emulation. Many ASCII terminals will also function properly.

To set up the terminal, use the field settings found in [“Setting Up HP AdvanceLink \(HP 68333F Version B.02.00\) on your PC” on page 235](#). As a minimum, make sure the terminal’s basic setup information matches the fields on the Test Set’s I/O CONFIGURE screen (refer to [Table 8-2 on page 229](#) for recommended settings).

## Choosing Your Development Method

There are three fundamental methods for developing IBASIC programs for the Test Set. See [Figure 8-4](#).

**Figure 8-4** Three Possible Development Methods

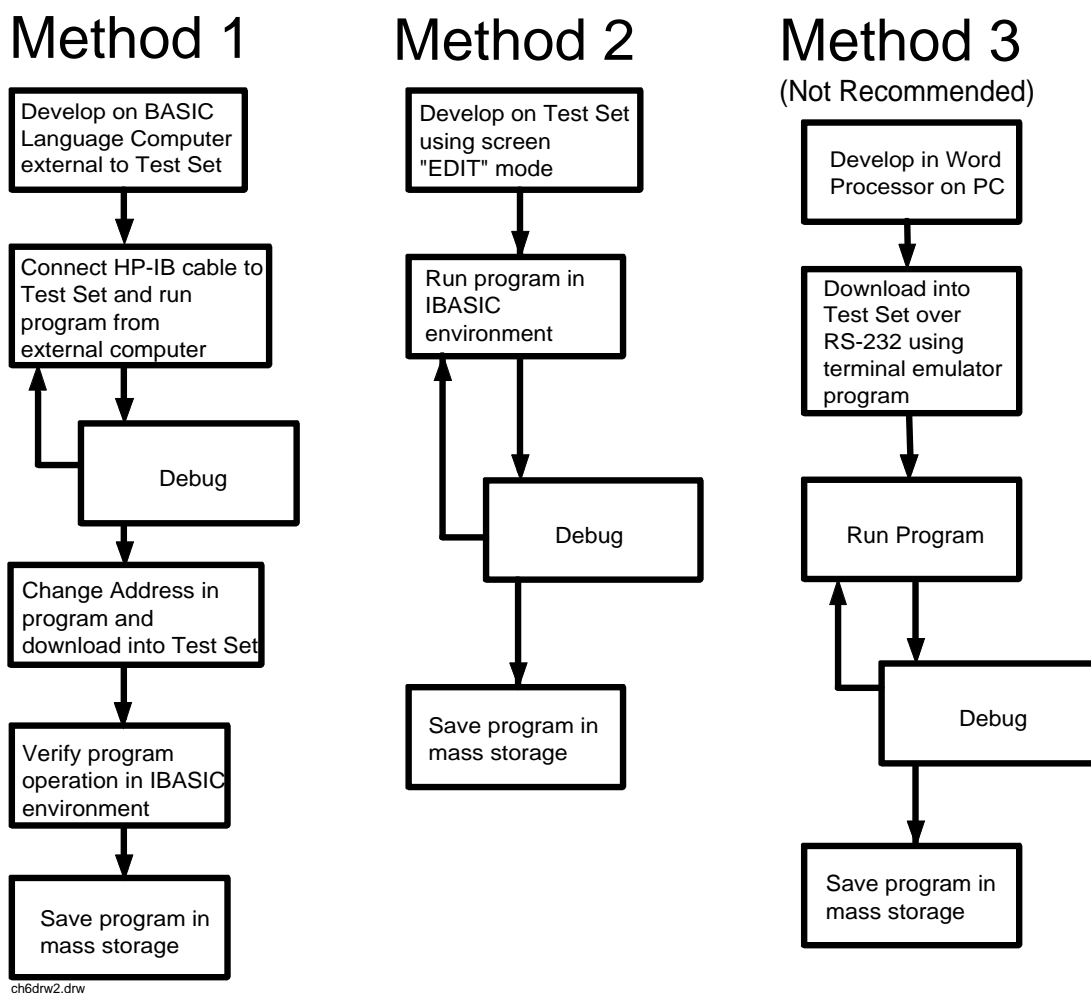

### Method 1

Using a BASIC language computer (either an HP technical computer or a PC running BASIC with HP-IB) is the best method for developing any size program. This is because the program can be debugged directly on the external computer before downloading the program into the Test Set. Using this approach the programmer can observe the Test Set's display to see changes in state and easily verify the correct measurements.

## Method 2

If a BASIC language computer is not available, program development can be done directly on the Test Set using the IBASIC EDIT mode. A PC connected to the Test Set through RS-232, as described earlier in this chapter, is used as the CRT and keyboard for the internal controller. In this method, the program always resides in the Test Set and can be run at any time. Mass storage is usually a PC card. When running IBASIC programs on the Test Set's internal controller, the Test Set displays only the IBASIC screen, not the individual instrument screens as the program executes. This makes troubleshooting larger programs more difficult.

## Method 3

The third method of program development is to use a word processor on a PC with RS-232, and then download the program into the Test Set for execution. This is the least favorable choice for development because downloading code into the Test Set over RS-232 requires a loader utility program running in the Test Set and a PC card present as an intermediate storage location before running the program. (For shorter programs, the intermediate storage location is not necessary.) No IBASIC command syntax is checked until the program is run after downloading. Also, when running IBASIC programs on the Test Set's internal controller, the Test Set displays only the IBASIC screen, not the individual instrument screens as the program executes. This makes troubleshooting larger programs more difficult.

---

## Method #1. Program Development on an External BASIC Language Computer

Connecting IBASIC Language Computers to the Test Set

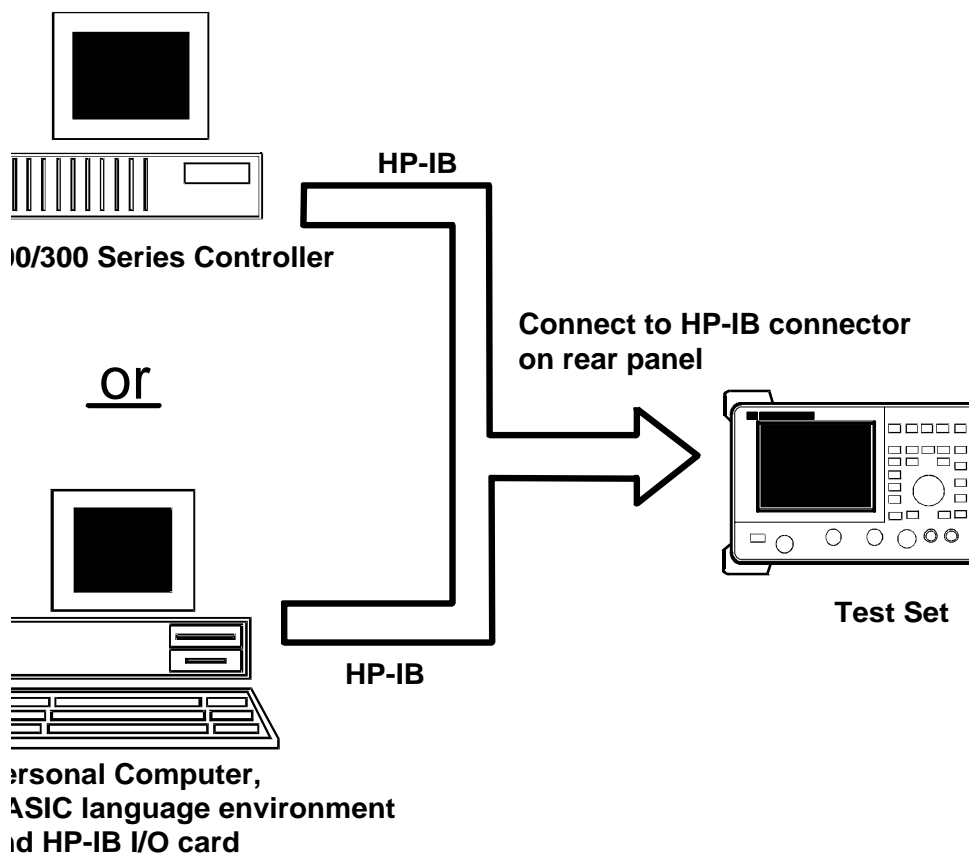



## Configuring the Test Set's HP-IB Interface

To use HP-IB (the IEEE 488 interface bus) as a means of communicating with the Test Set, connect a standard HP-IB cable (such as the HP 10833B) between the Test Set's rear-panel HP-IB connector and the HP-IB connector on the external BASIC language computer.

- On the Test Set
1. Select the I/O CONFIGURE screen.
  2. Set the Mode field to Talk&Lstn.

---

**NOTE**

If the Mode field is set to Control, there could possibly be a System Controller conflict between the external BASIC language computer and the Test Set, resulting in either an Interface Status Error or "lock up" of the HP-IB. Refer to "Passing Control" on page 187.

---

3. Set the HP-IB Adrs field to the desired address for the Test Set. The default value is 14.

## Compatible BASIC Language Computers

As shown in [Figure on page 240](#), there are two types of computers that can be used in this development method.

- The HP 9000 Series 200/300 Workstation running HP Rocky Mountain BASIC 6.2 or later. IBASIC is a subset of HP Rocky Mountain BASIC (RMB). All IBASIC commands are compatible with RMB and thus will execute from a HP 9000 Series 200/300 Workstation.
- A PC, running Windows 3.1 or Windows NT, with HP BASIC for Windows and an HP-IB interface card can be used.

## HP BASIC for Windows PC Configuration for Windows NT Operating System

To prepare for HP BASIC program development utilizing Windows NT, the external PC must be configured to operate with the Test Set.

You will need:

- an HP 82341B/C interface card (the HP 82335 card does not support Windows NT)
- a licensed version with security key of HP BASIC for Windows. You can get the latest files from:

<ftp://hpislsup.lvld.hp.com/pub/pc/index.html>.

Select the HP BASIC for windows archives and follow the instructions for download.

How to install:

1. Install the HP 82341B/C into an open expansion slot. Refer to the interface card's installation guide details. Utilize the default card settings.
2. Install the SICL libraries using the SETUP32.EXE setup file.
3. Run the SICL I\_O Config program to configure the card.
4. Select HP 82340/82341 HP-IB from the available interface list of choices.
5. Select the Configure command button. Use the default settings shown by the program. This will verify that the card is functioning.
6. Install HP BASIC for Windows 6.3 or later.
7. Run HP BASIC for Windows.
8. Edit the AUTOST file, change line 330 as follows:

### Example

```
LOAD BIN "HPIBS;DEV hpib7" !SICL Library for HP 82341 card
```

9. Re-store the AUTOST file
10. Quit HP BASIC for Windows
11. Run HP BASIC for Windows. The program should load normally and allow you to send orders to the Test Set.

## Program Development Procedure

As discussed in “[Overview of the Test Set](#)” on page 18, the Test Set has two HP-IB buses, an internal HP-IB at select code 8 and an external HP-IB at select code 7. The Test Set’s built-in IBASIC controller uses the internal HP-IB to communicate with the Test Set’s various instruments and devices. The process of developing a program on an external BASIC language computer utilizes this hardware feature to an advantage. First, develop the program directly on the external BASIC language computer treating the Test Set as a device on the external BASIC language computer’s HP-IB. For example, to setup the Test Set’s RF Generator use the OUTPUT command with the Test Set’s HP-IB address. If the select code of the HP-IB card in the external BASIC language computer is 7 and the address of the Test Set is 14 the address following the OUTPUT command would be 714. When the command executes on the external BASIC language computer the information on how the Test Set’s RF Generator is to be configured is sent to the Test Set through its external HP-IB bus. After the program is fully developed, making it run on the Test Set is simply a matter of changing the address of all the HP-IB commands to 8XX (Test Set internal HP-IB bus) and downloading the program into the Test Set’s IBASIC controller and executing it.

There are two ways of allowing easy conversion of all HP-IB commands to a different address.

- The first way is to establish a variable to which the 3-digit address number is assigned.

### Example

```
10 Addr = 714 ! Sets the value of variable Addr to be 714.  
20 OUTPUT Addr;"*RST"!Commands the Test Set to reset at address 714.
```

To change the address, simply change the value of variable Addr to 814:

### Example

```
10 Addr = 814 ! Sets the value of variable Addr to be 814.  
20 OUTPUT Addr;"*RST"! Commands the Test Set to reset at address 814.
```

- A second method is to assign an I/O path to the desired I/O port.

To control device #14 on the port with select code 7:

**Example**

```
20 ! Establishes IO path to select code 7 address 14
10 ASSIGN @Device TO 714
30 ! Commands Test Set to reset at address 714.
20 OUTPUT @Device;"*RST"
```

To change the address, simply change line 10 to

**Example**

```
10 ASSIGN @Device TO 800.
```

---

**NOTE**

The dedicated HP-IB interface at select code 8 conforms to the IEEE 488.2 Standard in all respects but one. The difference being that each instrument on the bus does not have a unique address. The Instrument Control Hardware determines which instrument is being addressed with the command syntax. As such an explicit device address does not have to be specified. The address 800 and 814 are equally correct.

---

## Downloading Programs to the Test Set through HP-IB

An IBASIC PROGRAM subsystem has been developed to allow the external BASIC language controller to download programs to the Test Set through HP-IB (refer to the [“PROGRAM Subsystem Commands” on page 266](#) for more information on the PROGRAM Subsystem). Four commands from the external BASIC language controller to the Test Set are necessary to transfer the program. The commands are executed serially allowing enough time for each command to finish executing. (The Test Set’s HP-IB Mode field must be set to Talk&Lstn, and the TESTS (IBASIC CONTROLLER) screen must be displayed).

1. OUTPUT 714; "PROG:DEL:ALL"

- Deletes any programs that reside in Test Set RAM.

2. OUTPUT 714; "PROG:DEF #0"

- Defines the address in Test Set RAM where the downloaded program will be stored.

3. LIST #714

- Causes all program lines to transfer over HP-IB to the Test Set which is at address 714.

4. OUTPUT 714; "END"

- Defines end of download process by generating an EOI command.

After the above commands complete the program code will be in the Test Set ready to run. If any bugs are detected when the program is run, the program can be uploaded back into the external BASIC language controller to correct the error. Alternately the full screen IBASIC EDIT function through RS-232 can be used to correct the error (refer to [“Method #2. Developing Programs on the Test Set Using the IBASIC EDIT Mode” on page 247](#) for details).

After the program is working properly in the Test Set IBASIC environment, it should be stored for backup purposes.

## Uploading Programs from the Test Set to an External BASIC Controller through HP-IB

To upload a program from the Test Set to an external BASIC language controller through HP-IB the following program, which uses a command from the PROGram subsystem to initiate the upload, must be running on the external BASIC language controller. The uploaded program is stored to a file specified by the user.

In the following program the external BASIC language controller is a PC running TransEra HT BASIC. The file is stored to the C:\HTB386 directory. If the external BASIC language controller is an HP 9000 Series 200/300 Workstation, modify the mass storage volume specifier appropriately. After running the program, the uploaded program code will be in the designated file. Use the GET command to retrieve the file for editing.

### Example

```

10 ! PROGRAM TO UPLOAD IBASIC CODE FROM TEST SET TO BASIC CONTROLLER THROUGH HP-IB.
20 !#####
30 !
40 ! The file for uploaded code will be "C:\htb386\code".
50 ! If you want to use a different file or directory, modify the two lines
60 ! with the labels "File_name_1" and "File_name_2".
70 !
80 !#####
90 Addr=714 !Test Set HP-IB address
100 ALLOCATE Line$(200)
110 PRINTER IS 1
120 CLEAR SCREEN
130 DISP "It may be several minutes before code begins transferring if program is long"
140 OUTPUT Addr;"*RST" !Reset the Test Set
150 OUTPUT Addr;"DISP TIB" !Displays the IBASIC screen
160 OUTPUT Addr;"PROG:EXEC 'CLS'" !Clears the Test Set display
170 OUTPUT 714;"PROG:DEF?" !Initiates the upload of whole program
180 ENTER Addr USING "X,D,#";Count_len!Number of lines in program
190 ENTER Addr USING VAL$(Count_len)&"D,#";Char_count !Number of characters
200 !
210 File_name_1: CREATE ASCII "C:\htb386\code", (1.05*Char_count/256)+5
220 ! Number of records reserved for upload.
230 File_name_2: ASSIGN @File TO "C:\htb386\code"
240 !
250 DISP "Transferring code from Test Set"
260 LOOP !Program transfer loop.
270 ENTER Addr;Line$ !CR/LF terminates each line.
280 PRINT Line$ !Displays new lines on Test Set display.
290 OUTPUT @File;Line$!Transfer new line to file.
300 Char_count=Char_count-LEN(Line$)-2 !Reduces Char_count by the number of
310 ! characters in current line.
320 EXIT IF Char_count<=0
330 END LOOP
340 !
350 ASSIGN @File TO *!Cleans out file buffer.
360 ENTER Addr;Line$!Close off reading
370 CLEAR SCREEN
380 DISP "Transfer complete."
390 LOCAL Addr
400 END

```

---

## Method #2. Developing Programs on the Test Set Using the IBASIC EDIT Mode

If a BASIC language computer is not available, program development can be done directly on the Test Set using the IBASIC EDIT mode. A terminal or PC connected to the Test Set through RS-232 is used as the CRT and keyboard for the Test Set's built-in IBASIC controller. In this method, the program always resides in the Test Set and can be run at any time. Mass storage is usually a PC card. When running IBASIC programs on the Test Set's internal controller, the Test Set displays only the IBASIC screen.

The Test Set's IBASIC controller has an editor that is interactive with a terminal or PC over the RS-232 serial port. (The editor does not work unless a terminal or PC with terminal emulator is connected to Serial Port 9.) The editor, hereafter referred to as the "IBASIC EDIT Mode", allows the programmer to develop code directly in the Test Set with no uploading or downloading. The IBASIC EDIT Mode can be used to develop programs from scratch or to modify existing programs. Refer to ["Interfacing to the IBASIC Controller using Serial Ports"](#) on page 226 for information on connecting a terminal or PC to the Test Set.

### Selecting the IBASIC Command Line Field

To use the IBASIC EDIT Mode for program development, the IBASIC Command Line field must be displayed on the Test Set and Serial Port 9 must be connected to the IBASIC Command Line field. An IBASIC command, sent as a series of ASCII characters through Serial Port 9, will appear on the IBASIC Command Line field. When a carriage return/line feed is encountered, the Test Set will attempt to execute the command. To display the IBASIC Command Line field on the Test Set execute the following steps:

1. Press the TESTS key.
2. The SOFTWARE MENU screen will be displayed.
3. Using the rotary knob, position the cursor on the IBASIC Cntrl field and select it.
4. The TESTS (IBASIC CONTROLLER) screen will be displayed.
5. The small horizontal rectangle at the top-left is the IBASIC Command Line.

**To Access the IBASIC Command Line Field**

1. Position the cursor on the screen's upper left. This is the IBASIC Command Line field.
2. The IBASIC Command Line field does not have a title like other fields in the Test Set; it is the highlighted, horizontal 2-line "bar" just below the screen title, TESTS (IBASIC Controller).

**To Use the IBASIC Command Line Field with the Test Set's Rotary Knob**

1. Position the cursor at the IBASIC Command Line field and push the knob.
2. A Choices: field will be displayed in the lower, right corner of the display.
3. By rotating the knob, a list of ASCII characters and cursor positioning commands can be displayed on the right side of the screen.
4. When the cursor is next to the desired character or command, push the knob to select that character.
5. No external hardware is required for this entry method, but it is tedious and is recommended only for short commands. Use this method when doing simple tasks such as initializing PC cards or CATaloging a PC card.
6. Program development using the rotary knob alone is not recommended.



## Entering and Exiting the IBASIC EDIT Mode

To enter the IBASIC EDIT Mode first position the cursor on the IBASIC Command Line field, type the word EDIT on the terminal or PC connected to the Test Set and then press the ENTER key on the terminal or PC. At this point the Test Set will fill the PC screen with 22 lines of IBASIC code from the program currently in the Test Set's RAM memory. No program lines will be displayed on the Test Set screen. If no program is currently in the Test Set's memory, the number 10 will be displayed on the terminal or PC screen. This represents program line number 10 and is displayed to allow you to begin writing an IBASIC program beginning at line number 10. The "\*" annunciator will be displayed in the upper, right corner of the Test Set indicating that the IBASIC controller is running to support the full screen edit mode.

After editing is complete, exit the IBASIC EDIT Mode by pressing the terminal or PC's ESCAPE key twice or pressing the SHIFT CANCEL keys on the Test Set.

A variety of editing commands are supported by the IBASIC EDIT Mode. These commands are activated in the Test Set as escape code sequences. Most terminals and PC terminal emulator programs allow function keys to be configured with user defined escape code sequences and user defined labels for the keys. An escape command (when received by a peripheral device like a printer or the Test Set) causes the peripheral to recognize subsequent ASCII characters differently. In the case of the Test Set, escape sequences are used for executing IBASIC EDIT Mode editing commands.

For example, ESCAPE [L causes the Test Set to insert a new line number where the cursor is positioned. [Table on page 250](#) lists the editing escape codes for the Test Set. There is no escape code for DELETE CHARACTER. Use the Backspace key for deleting. Use the arrow keys to position the cursor.

## Setting Up Function Keys In Microsoft Windows Terminal

When in the TERMINAL mode, click on Settings, then Function Keys. ^[ is ESCAPE in Windows Terminal. See [Table on page 250](#) for the escape codes.

---

**NOTE**

Windows Terminal seems to work best when a mouse is used to access the function keys, not the keyboard. Also, scrolling a program works best when the Terminal window display is maximized).

---

## Setting Up Function Keys in HP AdvanceLink

- From the Main (highest level) screen, set up the 8 softkeys as follows:
  1. Display User Definition screens by pressing Ctrl F9.
  2. Enter all the LABEL titles for K1 through K8.
  3. Activate the “Display Function” feature by pressing softkey F7.
  4. Now you can enter the escape codes for each edit command aligned with the soft key definitions you just entered. With the Display Functions key pressed, when you press the escape key, a left arrow will be displayed.
- Once you have set up all 8 keys, you activate them by pressing Shift F12. To deactivate your user defined softkeys, press F12.
- (- is ESCAPE in HP AdvanceLink. See [Table on page 250](#) for the escape codes.

## Setting Up Function Keys in ProComm

ProComm does not have function keys. However, escape sequences can be assigned to number keys 0 through 9 by using the Keyboard Macro function. This function is accessed by keying Alt+M. There is no method of displaying key labels so they will have to be recorded elsewhere. See the ProComm manual for further information.

### Edit Mode Escape Code Commands

Function Key Names	Windows Terminal Escape Codes	HP AdvanceLink Escape Codes
INSERT LINE	^[[L	(-[L
DELETE LINE	^[[M	(-[M
GO TO LINE	^[g	(-g
CLEAR LINE	^[[K	(-[K
PAGE UP	^[OQ	(-OQ
PAGE DOWN	^[OR	(-OR
RECALL LINE	^[r	(-r
BEGIN LINE	^[OP	(-OP
END LINE	^[OS	(-OS

## **Method #3. Developing Programs Using Word Processor on a PC (Least Preferred)**

The third method of IBASIC program development is to write the program using a word processor on a PC, save it as an ASCII file, and then download it into the Test Set through the serial port. The benefit of this method is that it can be done on the PC without connecting to a Test Set until download and no BASIC language compiler/interpreter is needed. The primary drawback is that no syntax checking occurs until the downloaded program is run on the Test Set. A second drawback is that, especially for longer programs (>100 lines), it is very time-consuming to transfer the code into the Test Set.

### **Configuring a Word Processor**

The word processor on which the IBASIC code is developed must be able to save the file in ASCII format and have an ASCII file transfer utility. This is necessary because word processors use a variety of escape codes to mark all the special display formats such as bold face, font size, indented text, and the like. When a word processor file is stored in ASCII format, all escape codes are stripped off. The ASCII file transfer utility is used to transfer the file to the Test Set.

---

**NOTE**

The GET command can be used on external BASIC language controllers to load ASCII files containing IBASIC programs developed on word processors. Once loaded, the steps for downloading described in [“Method #1. Program Development on an External BASIC Language Computer” on page 240](#) can be used to transfer the program to the Test Set.

---

## Writing Lines of IBASIC Code on a Word Processor

When writing IBASIC programs, follow these steps to ensure that the Test Set will accept the code when it is downloaded.

1. Always begin new lines at the far left margin. Never use a leading space or tab.
2. Number each consecutive line just like an IBASIC language program.
3. Typically begin with 10 and increment by ten for each consecutive line.
4. Do not leave any space or double space between lines.
5. Make sure to use hard carriage return / line feeds at the end of each line.
6. When saving the completed program, save it as an ASCII file. Some word processors have ASCII options which require that the user specify CR/LF at the end of each line. It is important that each line end with a carriage return / line feed.
7. Experiment with a short program first to make sure everything is working correctly.

## Transferring Programs from the Word Processor to the Test Set

For short (less than 100 lines) programs, use an ASCII file transfer utility on the PC to send the program, one line at a time, down to the Test Set over RS-232 directly into the IBASIC Command Line field. The Test Set must be configured to receive serial ASCII characters by positioning the Test Set cursor at the IBASIC Command Line field as explained under “[Method #2. Developing Programs on the Test Set Using the IBASIC EDIT Mode](#)” on page 247. With this setup, when ASCII characters are received they are sent to the IBASIC Command Line field. When a carriage return / line feed is received, the Test Set will parse the line into the IBASIC program memory. Each line takes about two seconds to scroll in and be parsed. This becomes very time consuming for long programs. An alternative for longer programs is discussed later in this section.

To start the transfer process make sure there is no program in the Test Set's IBASIC RAM memory by executing a SCRATCH command from the IBASIC Command Line.

The following example shows how to transfer a short program (<100 lines) using Microsoft Windows Terminal.

1. Make sure the Test Set cursor is in the upper left of the IBASIC Command Line field.
2. Select the Terminal application in the Accessories Group. Set it up as described in earlier in this chapter.
3. Select the following:
  - Settings
  - Text Transfers
  - Flow Control: Line at a Time
  - Delay Between Lines: 25/10 Sec
  - Word Wrap
  - Outgoing Text at Column: Off.
4. Select the following:
  - Transfers
  - Send Text File
  - Following CR:
    - Strip LF selected
    - Append LF not selected.
5. Select the text file to be transferred and begin the transfer by selecting (OK).

As the transfer starts the IBASIC Command Line field will intensify and characters will scroll in left to right. As each line is finished the "\*" annunciator will be displayed, for about 0.5 seconds, in the upper, right corner of the Test Set indicating that the IBASIC controller is running as the line is parsed. If another line is sent before this parsing is complete, the Test Set will beep indicating an error, and the next line of the transfer will be rejected.

If the transfer is rejected, the transfer must be halted and the delay between lines increased to a slightly higher number. Start the transfer again from the beginning. When all lines have transferred, list the program to verify it was completely received. At this time, the program is ready to run. The RUN command can be keyed in from the PC or the K1 Run key in the TESTS (IBASIC Controller) screen can be pressed.

---

**NOTE**

---

Do not press the Run Test key in the SOFTWARE MENU screen as this will scratch the program you just loaded and look to the PC card for a procedure file.

For longer programs (greater than 100 lines), transferring the ASCII text file directly into the IBASIC program memory through the RS-232 serial port is too time consuming. To speed the process up, it is necessary to transfer the program using a two step process.

1. Transfer the ASCII text file directly to a Test Set mass storage location (typically a PC card).
2. Perform a GET command to bring the program from mass storage into the IBASIC program memory.

To perform the ASCII text file transfer for long programs, an IBASIC program, running in the Test Set, is required to manage the transfer. A suitable program titled "ASCII\_DN" (for ASCII downloader) is shown on the following page.

The ASCII\_DN program runs on the Test Set and directs ASCII characters coming in Serial Port 9 directly to a file named TEMP\_CODE on a PC card. The program creates the TEMP\_CODE file on the PC card with a size of 650 records (166 Kbytes or enough for about 6600 lines of ASCII text). When the program is run, it displays Ready to receive ASCII file data. When this prompt is displayed, initiate the transfer of the ASCII text file representing the program from the PC to the Test Set. Shown below are two methods of sending an ASCII file from the PC to the Test Set. Both methods require that the ASCII\_DN program be running in the Test Set when the transfer begins. The ASCII\_DN program can be transferred into the Test Set either by typing it in using the IBASIC EDIT Mode described earlier, or downloading it from an ASCII text file one line at a time as explained earlier.

**Example**

```

10 ! ASCII_DN
20 ! Program to download ASCII program file from PC to the Test Set through RS-232
30 ! #####
40 !
50 ! This program must be loaded into the Test Set and run on the Test Set.
60 ! It directs ASCII characters that come in the Serial Port 9 to a file
70 ! named "TEMP_CODE" on a PC card. After the transfer is complete,
80 ! you must SCRATCH this program and GET the transferred program from
90 ! the "TEMP_CODE" file.
100 !
110 ! #####
120 COM /File_name/ File_name$[10]
130 DIM In$[200]
140 File_name$="TEMP_CODE" !File name on RAM card
150 CLEAR SCREEN
160 CLEAR 9!Clears Test Set serial bus
170 OUTPUT 800;"*RST"
180 ! Set up Test Set Serial Port 9 to receive ASCII text file
190 OUTPUT 800;"CONF:SPORT:BAUD '9600';PAR 'None';DATA '8 Bits'"
200 OUTPUT 800;"CONF:SPORT:STOP '1 Bit';RPAC 'Xon/Xoff';XPAC 'Xon/Xoff'"
210 OUTPUT 800;"CONF:SPORT:SIN 'IBASIC';IBECHO 'OFF'"
220 CALL Code(File_name$,In$)
230 END
240 Purge_it:SUB Purge_it!Purges File_name on card
250 COM /File_name/ File_name$
260 OFF ERROR
270 PURGE File_name$&":INTERNAL"
280 SUBEND
290 Code:SUB Code(File_name$,In$)
300 ON ERROR CALL Purge_it !Branches if CREATE statement returns error
310 CREATE ASCII File_name$&":INTERNAL",650 !Creates file on card
320 OFF ERROR
330 ASSIGN @File TO File_name$&":INTERNAL"
340 PRINT TABXY(1,5);"Ready to receive ASCII file data."
350 PRINT
360 Begin:ON TIMEOUT 9,1 GOTO Begin !Loops until data begins coming
370 ENTER 9;In$
380 OUTPUT @File;In$
390 PRINT In$
400 Transfer:LOOP !Loops to bring in ASCII file one line at a time
410 ON TIMEOUT 9,5 GOTO Done !Exit loop if data stops for >5 sec.
420 ENTER 9;In$
430 PRINT In$
440 OUTPUT @File;In$
450 END LOOP
460 Done:ASSIGN @File TO *
470 CLEAR SCREEN
480 ! Returns Test Set Serial Port 9 input to "instrument" allowing serial
490 ! communication to the IBASIC Command line field.
500 OUTPUT 800;"CONF:SPORT:SIN 'Inst';IECHO 'ON';IBECHO 'ON'"
510 PRINT TABXY(1,5);"Down load of ASCII file is complete."
520 SUBEND

```

## Sending ASCII Text Files Over RS-232 With Windows Terminal

Set up the Windows Terminal emulator software on the PC as covered in “[Setting Up Microsoft Windows® Terminal on your PC \(Windows Version 3.1\)](#)” on page 231. Load and run the ASCII\_DN download program in the Test Set’s IBASIC controller. When the prompt `Ready` to receive ASCII file data is displayed on the Test Set, make the following settings in Windows Terminal on the PC:

1. Select `Settings`.
2. Select `Text Transfers`.
3. Select `Flow Control: Standard Flow Control`.
4. Select `Word Wrap Outgoing Text at Column: unselected`.
  - This will use `Xon/Xoff` flow control by default.
5. Select `OK`.
6. Select `Transfers`.
7. Select `Send Text File`.
8. Set `Strip LF` off and `Append LF` off. (It is important that the line feeds that are in the ASCII file not be stripped or the file transfer will not work).
9. Select or enter the file name to transfer.
10. Begin the transfer by selecting `OK`.

At this point, each line of the program will rapidly scroll across the screen of the Test Set. When the transfer is finished, the prompt `Download of ASCII file complete.` will be displayed on the Test Set.

Before running the downloaded program, execute a `SCRATCH` command on the IBASIC Command Line to remove the `ASCII_DN` download program from Test Set memory.

Next, execute a `GET TEMP_CODE` command on the IBASIC Command Line. This will load the ASCII text into the IBASIC program memory.

Finally, execute a `RUN` command on the IBASIC Command Line. This will run the program. If any syntax errors are present in the program IBASIC will generate the appropriate error messages.



## Sending ASCII Text Files over RS-232 with ProComm Communications Software

Set up the ProComm terminal emulator software on the PC as covered in [“Setting Up ProComm Revision 2.4.3 on your PC” on page 233](#). On the Test Set, enter and run the ASCII\_DN download program in the IBASIC controller. When the prompt `Ready to receive ASCII file data` is displayed on the Test Set, make the following settings in the ProComm terminal emulator on the PC:

---

**NOTE**

---

The ProComm terminal emulator views the file transfer as sending the file from the PC “up” to the Test Set. This is opposite to the direction used by the previous Windows Terminal example. Therefore, with ProComm an ASCII “upload” transfer is used.

1. Press Alt+F10 to display the ProComm help screen.
2. Press Alt+P to display the `SETUP MENU`.
3. Select item 6: `ASCII TRANSFER SETUP`.
4. Set Echo locally: `NO`.
5. Expand blank lines: `YES`.
6. Pace character: `0`.
7. Character pacing: `15`.
8. Line pacing: `10`.
9. CR translation: `NONE , LF`.
10. Translation: `NONE` (This is important since the default setting will strip line feeds and this will cause the transfer to never begin).
11. Select the Escape key to exit setup mode and return to the main screen.
12. Press Alt F10 to access the help menu.
13. To begin sending the file, select `PgUp`.
14. In the `UPLOAD` screen, select 7 `ASCII` protocol.
15. Run the `ASCII_DN` download program on the Test Set.
16. When the Test Set displays `Ready to receive ASCII file data`, press Enter on the PC to begin the transfer. At this point, each line of the program will rapidly scroll across the screen of the Test Set. When the transfer is finished, the download program will display `Down load of ASCII file complete.`, and the program file will be stored on the PC card in the `TEMP-CODE` file.

17. Before running the transferred program, execute a SCRATCH command on the IBASIC Command Line line to remove the ASCII\_DN download program from Test Set memory.
18. Next, execute a GET TEMP\_CODE command on the IBASIC Command Line. This will load the ASCII text into the IBASIC program memory.
19. Finally, execute a RUN command on the IBASIC Command Line. This will run the program. If any syntax errors are present in the program IBASIC will generate the appropriate error messages.

## Uploading Programs from the Test Set to a PC

As an overview, the following steps must be performed:

1. The Test Set must output the program over Serial Port 9.
2. The PC must receive the data through its serial port and direct the data to a file on disk. This can be done by a terminal emulator program such as Windows Terminal, ProComm, or HP AdvanceLink. This requires having the serial port connection established as outlined in [“Interfacing to the IBASIC Controller using Serial Ports”](#) on page 226.

To configure the Test Set to output the program to Serial Port 9 position the cursor on the IBASIC Command Line field. Execute the command `PRINTER IS 9`. This command sets Serial Port 9 as the default printer port. When `PRINT` commands are executed, ASCII characters will be sent to Serial Port 9.

On the PC, select `Receive Text File` in Windows Terminal or `Receive Files (PgDn which is called Download)` in ProComm. Enter a file name, then initiate the file transfer. The PC is now looking for ASCII text to come in the serial port.

Load the program to be transferred into the Test Set. Execute the IBASIC `LIST` command on the IBASIC Command Line. The program listing will be sent to Serial Port 9 and be received by the terminal emulator software on the PC. When the listing is finished, terminate the file transfer by selecting `Stop` on Windows or `Escape` on ProComm.

## Serial I/O from IBASIC Programs

There are two serial ports available for I/O (input / output) to peripherals external to the Test Set. To bring data in to the Test Set through the serial port(s) use the IBASIC ENTER command. To send data out, use the OUTPUT command.

### Serial Ports 9 and 10

The Test Set uses a small DB-9 connector on the rear panel for connecting to the two serial ports. For information about serial port configuration, refer to the [“Test Set Serial Port Configuration” on page 226](#).

Before using either port, the RS-232 protocol must be established by setting baud rate, pacing, and the other settings as explained in [“Test Set Serial Port Configuration” on page 226](#). Functionally, from an I/O perspective, the two serial ports are identical. However, operationally there is one major difference. The Serial Port Address 9 settings are adjustable on the I/O CONFIGURE screen or with IBASIC commands, while the Serial Port 10 settings are adjustable only with IBASIC commands. There is no screen for Serial Port 10 settings. For more information, see the *HP-IB Syntax Reference Guide* which gives the command syntax for Serial Port 9 and 10.

## Example IBASIC Program Using Serial Port 10

The following program illustrates I/O to both serial ports. The program sends a prompt message to a terminal connected to Serial Port 9 and waits for a response from the user at the terminal. When the response is received from the terminal connected to Serial Port 9, a series of ASCII characters are sent out Serial Port 10.

### Example

```

10 !....ASCII CHARACTER CYCLER.....
30 !....be connected to a terminal at 9600 baud.
40 !....Outputs ASCII characters on Serial Port 10 beginning with      ASCII
50 !.....character 32 (space) and ending with ASCII character 126    (~).
60 !.....Characters are output with no CR/LF
70 OUTPUT 9;"When you are ready to send data on port10,press ENTER"
80 OUTPUT 800;"CONF:SPOR:SIN 'IBASIC';BAUD '9600'"
90 !Allows IBASIC to read port 9
100 DIM A$(10)
110  ENTER 9;A$ !Program waits here until CR/LF is received.
120 !.....
130 I=32
140 WHILE I<=126
150 OUTPUT 10 USING "K,#";CHR$(I)
160 !Outputs characters all on one line.
170 OUTPUT 10 USING "K,#";CHR$(I)
180 !Outputs characters all on one line.
190 END WHILE
200 OUTPUT 800;"CONF:SPOR:SIN 'Inst'" !Sets port 9 to IBASIC entry field.
180 EXECUTE ("CURSOR HOME") !Places cursor at left of IBASIC entry field
190 END

```

## Serial Port 10 Information

Serial Port 10 is sometimes called Serial Port B in Test Set documentation and programs.

The default Serial Port 10 settings are the same as Serial Port 9. They are

1. Serial Baud rate: 9600
2. Parity: None
3. Data Length: 8 Bits
4. Stop Length: 1 Bit
5. Receive and Transmit Pacing: Xon/Xoff
6. Serial in: Not available for Port 10
7. IBASIC and Instrument Echo: Not available for Port 10

There is no Test Set screen that shows Serial Port 10's settings. Therefore, to know Serial Port 10 settings, they must either be set or queried using IBASIC commands.

For example, the following IBASIC program queries the baud rate setting of Serial Port 10:

### Example

```
10 DIM Setting$(20)
20 OUTPUT 800;"CONF:SPB:BAUD?" !Initiates a query.
30 ENTER 800;Setting$
40 DISP Setting$
50 END
```

This program returns a quoted string. If the baud rate is set to 9600, the returned ASCII character string is 9600. Serial Port 10 settings are held in non-volatile memory. They remain unchanged until modified using an IBASIC command.

---

# PROGram Subsystem

## Introduction

The PROGram Subsystem provides a set of commands which allow an external controller to generate and control an IBASIC program within the Test Set. The PROGram Subsystem in the Test Set is a limited implementation of the PROGram Subsystem defined in the Standard Commands for Programmable Instruments (SCPI) Standard. The PROGram Subsystem commands, as implemented in the Test Set, can be used to

- download an IBASIC program from an external controller into the Test Set
- upload an IBASIC program from the Test Set into an external controller
- control an IBASIC program resident in the Test Set from an external controller
- set or query program variables within an IBASIC program which is resident in the Test Set
- execute IBASIC commands in the Test Set's IBASIC Controller from an external controller

## SCPI PROGram Subsystem

The SCPI PROGram Subsystem was designed to support instruments which can store multiple programs in RAM memory at the same time. The SCPI PROGram Subsystem provides commands which allow multiple programs to be named, defined and resident in the instrument at the same time. The Test Set does not support this capability.

For complete information on the SCPI PROGram Subsystem refer to the Standard Commands for Programmable Instruments (SCPI) Standard. If you are not familiar with SCPI, it is recommended that you obtain a copy of the book: *A Beginner's Guide to SCPI* (ISBN 0-201-56350, Addison-Wesley Publishing Company).

## Test Set PROGram Subsystem

The Test Set was designed to store only one IBASIC program in RAM memory at any given time. The PROGram Subsystem commands, as implemented in the Test Set, operate differently than described in the SCPI Standard. In addition, the SCPI PROGram Subsystem commands which were designed to support multiple programs are not supported in the Test Set.

### Supported SCPI Commands

The Test Set supports the following subset of the :SElected SCPI commands.

- :SElected:DEFine
- :SElected:DEFine?
- :SElected:DELeTe:ALL
- :SElected:EXECute
- :SElected:NUMBer
- :SElected:NUMBer?
- :SElected:STATe
- :SElected:STATe?
- :SElected:STRing
- :SElected:STRing?
- :SElected:WAIT



## Unsupported SCPI Commands

The Test Set does not support the following SCPI commands.

:CATalog?  
:SELected:DELEte:SELected  
:SELected:MALLocate  
:SELected:MALLocate?  
:SELected:NAME  
:SELected:NAME?  
:EXPLicit:DEFine  
:EXPLicit:DEFine?  
:EXPLicit:DELEte  
:EXPLicit:EXECute  
:EXPLicit:MALLocate  
:EXPLicit:MALLocate?  
:EXPLicit:NUMBer  
:EXPLicit:NUMBer?  
:EXPLicit:STATe  
:EXPLicit:STATe?  
:EXPLicit:STRing  
:EXPLicit:STRing?  
:EXPLicit:WAIT

---

**NOTE**

Sending the Test Set any of the unsupported SCPI PROGram Subsystem commands can result in unexpected and/or erroneous operation of IBASIC. This may require the Test Set's RAM to be initialized from the SERVICE screen to regain proper IBASIC operation.

---

## PROGram Subsystem Commands

See the “:PROGram Subsystem in the *HP-IB Syntax Reference Guide*, for PROGram Subsystem command syntax rules.

### Command Notation

The following notation is used in the command descriptions:

- Letter case (uppercase or lowercase) is used to differentiate between the short form (the uppercase characters) and long form (the whole keyword) of the command.
- The lower case letters in the keyword are optional; they can be deleted and the command will still be understood by the Test Set.
- [ ] = Optional keyword; this is the default state, the Test Set will process the command to have the same effect whether the optional keyword is included by the programmer or not.
- < > = Specific SCPI-defined parameter types. Refer to the SCPI Standard for definitions of the SCPI-defined parameter types.
- { } = One or more parameters that must be included one or more times.
- | = Separator for choices for a parameter. Can be read the same as “or.”

### Command Descriptions

---

#### NOTE

When a PROGram Subsystem command is sent to the Test Set through HP-IB from an external controller the Test Set is put into REMOTE mode. The Test Set must be put in LOCAL mode to use the front-panel keys or to use the serial ports to input data into the IBASIC Command line.

---

**[:SElected]**. All the commands under this keyword access the IBASIC program currently resident in the Test Set. Note that this keyword is optional in the command syntax.

#### Syntax

PROGram[:SElected]

**:DEFine <program>.** The DEFine command is used to create and download an IBASIC program into the Test Set from an external controller.

To download an IBASIC program, any currently resident IBASIC program must first be deleted using the :DELeTe:ALL command. Attempting to download a new IBASIC program while an IBASIC program is currently resident causes IBASIC Error: -282 Illegal program name.

---

NOTE

It is possible for the PROGram Subsystem to think that there is an IBASIC program resident in the Test Set when, in actuality, there is not. This situation would exist for example, if an IBASIC program had been created and downloaded using the :DEFine command and then deleted, from the front panel, using the SCRATCH ALL command from the IBASIC Command line. Under this circumstance IBASIC Error -282 would be generated when another attempt is made to download a program with the PROGram Subsystem. It is recommended that the :DELeTe:ALL command always be sent immediately before the :DEFine command.

---

The IBASIC program downloaded into the Test Set must be transferred as IEEE 488.2 Arbitrary Block Program Data. Refer to the IEEE Standard 488.2-1987 for detailed information on this data type. Two syntax forms are provided with the Arbitrary Block Program Data data type: one form if the length of the program is known and another one if it is not.

**Syntax (length of program not known)**

```
PROGram[:SELeCted]:DEFine <#0><program><NL><END>
```

The following notation is used in the command description:

- <#0> = IEEE 488.2 Arbitrary Block Program Data header.
- <program> = the IBASIC program sent as 8 bit data bytes.
- <NL> = new line = ASCII line-feed character.
- <END> = IEEE 488.1 END message. This terminates the block transfer and is only sent once with the last byte of the indefinite block data.

### Example BASIC program to download an IBASIC program to Test Set

```
10 OUTPUT 714;"PROG:DEL:ALL"!Delete current program
20 OUTPUT 714;"PROG:DEF #0"!Create program, send header
30 OUTPUT 714;"10 FOR J = 1 TO 10"!1st prog line
40 OUTPUT 714;"20 DISP J"!2nd prog line
50 OUTPUT 714;"30 BEEP"!3rd prog line
60 OUTPUT 714;"40 NEXT J"!4th prog line
70 OUTPUT 714;"50 END"END!Send END message at end of last line
80 END
```

### Syntax (length of program known)

```
PROGRAM[:SElected]:DEFine <#><of digits in count field>
<count field: of data bytes in program><program data bytes>
```

The following notation is used in the command description:

- The data starts with a header which begins with a “#”, followed by a single non-zero digit in the range 1-9 which specifies the number of digits in the following count field, followed by a series of digits in the range of 0-9 which gives the number of data bytes being sent, followed by the number of data bytes specified by the count field.

### Example

```
#16<data byte><data byte><data byte><data byte><data byte><data byte>
```

### Example BASIC program to download an IBASIC program to Test Set

```
10 OUTPUT 714;"PROG:DEL:ALL" !Delete current program
20 OUTPUT 714;"PROG:DEF #257" !Create program, send header
30 OUTPUT 714;"10 FOR J = 1 TO 10" !18 characters + CR + LF
40 OUTPUT 714;"20 DISP J" !9 characters + CR + LF
50 OUTPUT 714;"30 BEEP" !7 characters + CR + LF
60 OUTPUT 714;"40 NEXT J" !9 characters + CR + LF
70 OUTPUT 714;"50 END"!6 characters
80 END
```

**:DEFine?.** The :DEFine? query command is used to upload an IBASIC program from the Test Set to an external controller.

The IBASIC program uploaded to the external controller is transferred as IEEE 488.2 Definite Length Arbitrary Block Response Data. The following information describes some of the characteristics of the IEEE 488.2 Definite Length Arbitrary Block Response Data type. Refer to the IEEE Standard 488.2-1987 for detailed information on this data type.

- The data starts with a header which begins with a "#", followed by a single non-zero digit in the range 1-9 which specifies the number of digits in the following count field, followed by a series of digits in the range of 0-9 which gives the number of data bytes being sent, followed by the number of data bytes specified by the count field.

#### Example

```
#16<data byte><data byte><data byte><data byte><data byte><data byte>
```

- The transfer is terminated by the transmission, from the Test Set to the external controller, of the response message terminator (NL & END message).
  - <NL> = new line = ASCII linefeed character.
  - <END> = IEEE 488.1 END message.

#### Syntax

```
PROGram[:SElected]:DEFine?
```

#### Example BASIC program to upload an IBASIC program from Test Set

```
10 DIM Prog_line$[200]!Holds longest program line in Test Set
20 DIM File_name$[10]!Holds the name of file to store IBASIC program
30 LINPUT "Enter name of file to store IBASIC program in:",File_name$
40 OUTPUT 714;"PROG:DEF?"
50 ENTER 714 USING "X,D,#";Count_length !Get length of count field
60 !Get number of characters in program, includes CR/LF on each line
70 ENTER 714 USING VAL$(Count_length)&"D,#";Chars_total
80 !Create ASCII file to hold program, add 5 records for buffer
90 CREATE ASCII File_name$, (Chars_total/256)+5
100 ASSIGN @File TO File_name$
110 LOOP
120 ENTER 714;Prog_line$ !Read in one program line
130 OUTPUT @File;Prog_line$ !Store in file
140 Chars_xferd=Chars_xferd+LEN(Prog_line$)+2 !CR/LF not read
150 EXIT IF Chars_xferd>=Chars_total
160 END LOOP
170 ENTER 714;Msg_terminator$ !Terminate the block data transfer
180 ASSIGN @File TO *
190 END
```

**:DELeTe:ALL.** The :DELeTe:ALL command is used to delete an IBASIC program in the Test Set. If the IBASIC program in the Test Set is in the RUN state, an IBASIC Error: -284 Program currently running error is generated and the program is not deleted.

### Syntax

```
PROGram[:SELeCted]:DELeTe:ALL
```

### Example

```
OUTPUT 714;"PROGram:SELeCted:DELeTe:ALL"
```

or

```
OUTPUT 714;"PROG:DEL:ALL"
```

**:EXECute <program\_command>.** The :EXECute command is used to execute, from an external controller, an IBASIC program command in the Test Set's built-in IBASIC Controller.

<program\_command> is string data representing any legal IBASIC command. If the string data does not represent a legal IBASIC command, an IBASIC Error: -285 Program syntax error is generated.

Any IBASIC program in the Test Set must be in either the PAUSed or STOPped state before the external controller issues the :EXECute <program\_command> command. If the IBASIC program is in the RUN state, an IBASIC Error: -284 Program currently running is generated.

### Syntax

```
PROGram[:SELeCted]:EXECute <delimiter><program_command><delimiter>
```

The following notation is used in the command description:

- <delimiter> = IEEE 488.2 <string data> delimiter, single quote or double quote, must be the same.

### Example

```
OUTPUT 714;"PROGram:SELeCted:EXECute 'CLEAR SCREEN'"
```

or

```
OUTPUT 714;"PROG:EXEC 'CLEAR SCREEN'"
```

**:NUMBER <varname>{,<nvalues>}** . The :NUMBER command is used to set, from an external controller, the value of numeric variables or arrays in an IBASIC program in the Test Set. <varname> is the name of an existing numeric variable or array, and can be sent as either character data (<varname> not enclosed in quotes) or string data (<varname> enclosed in quotes). <nvalues> is a list of comma-separated <numeric\_values> which are used to set the value of <varname>.

---

**NOTE**

If the variable name <var\_name> is longer than 12 characters it must be sent as string data (<var\_name> enclosed in quotes). For example, OUTPUT 714;"PROG:NUMB 'Var\_name',10".

Attempting to send a <var\_name> longer than 12 characters as character data (<var\_name> *not* enclosed in quotes) will generate the following error: HP-IB Error: -112 Program mnemonic too long.

---

If an attempt is made to set the value of a numeric variable or array and no IBASIC program is in the Test Set an IBASIC Error: -282 Illegal program name is generated. If an attempt is made to set the value of a numeric variable or array and the numeric variable specified in <varname> does not exist in the program an IBASIC Error: -283 Illegal variable name is generated. If the specified numeric variable cannot hold all of the specified <numeric\_values> an IBASIC Error: -108 Parameter not allowed is generated.

**Syntax**

PROGram[:SElected]:NUMBER <varname>{,<nvalues>}

**Example setting the value of a simple variable**

OUTPUT 714;"PROGram:SElected:NUMBER Variable,15"

**or**

OUTPUT 714;"PROG:NUMB Variable,15"

**Example setting the value of a one dimensional array [Array(5)] with 6 elements**

OUTPUT 714;"PROGram:SElected:NUMBER Array,0,1,2,3,4,5"

**or**

OUTPUT 714;"PROG:NUMB Array,0,1,2,3,4,5"

---

**NOTE**

Individual array elements cannot be set with the :NUMBER command.

**Example setting the value of a two dimensional array [Array(1,2)] with 6 elements**

```
OUTPUT 714; "PROG:SELEcted:NUMBer Array,0,1,2,3,4,5"
```

**or**

```
OUTPUT 714; "PROG:NUMB Array,0,1,2,3,4,5"
```

Arrays are filled by varying the right-most dimension the fastest. After executing the above statement the array values would be, Array(0,0)=0, Array(0,1)=1, Array(0,2)=2, Array(1,0)=3, Array(1,1)=4, Array(1,2)=5.

---

**NOTE**

Individual array elements cannot be set with the :NUMBer command.



**:NUMBer? <varname>** . The :NUMBer? query command is used to return, to an external controller, the current value of numeric variables or arrays in an IBASIC program in the Test Set. <varname> is the name of an existing numeric variable or array in the IBASIC program, and can be sent as either character data (name not enclosed in quotes) or string data (name enclosed in quotes).

---

NOTE

Attempting to send a <var\_name> longer than 12 characters as character data (<var\_name> *not* enclosed in quotes) will generate the following error: HP-IB Error: -112 Program mnemonic too long.

If the variable name <var\_name> is longer than 12 characters it must be sent as string data (<var\_name> enclosed in quotes). For example, OUTPUT 714;"PROG:NUMB 'Var\_name'".

---

For simple variables the value is returned as a series of ASCII characters representing a numeric value in scientific notation (+3.0000000000E+000). For arrays the values are returned as a comma separated list of ASCII characters representing a numeric value in scientific notation. For example:

```
+3.0000000000E+000,+3.0000000000E+000,+3.0000000000E+000...
```

Array values are sent by varying the rightmost dimension of the array the fastest.

If an attempt is made to query the value of a numeric variable or array and no IBASIC program is in the Test Set an IBASIC Error: -283 Illegal variable name is generated. If an attempt is made to query the value of a numeric variable or array and the variable specified in <varname> does not exist in the program an IBASIC Error: -283 Illegal variable name is generated.

**Syntax**

```
PROGram[:SElected]:NUMBer? <varname>
```

---

NOTE

The program commands and syntax used to enter data from the Test Set into the external controller will depend upon the programming language used in the external controller. Considerations such as type conversion (integer to real, real to complex, etc.), the sequence in which values are entered into arrays, the capability to fill an entire array with a single enter statement, etc. will depend upon the capabilities of the programming language used in the external controller. The examples which follow represent the capabilities of HP Rocky Mountain BASIC programming language running on an HP 9000/300 Series Controller.

---

### Example querying the value of a simple variable

```
OUTPUT 714;"PROG:SElected:NUMBER? Variable"  
ENTER 714;Value
```

**or**

```
OUTPUT 714;"PROG:NUMB? Variable"  
ENTER 714;Value
```

In this example, the variable named Value in the ENTER statement must be the same type as the variable named Variable in the IBASIC program.

### Example querying the value of a one dimensional array [Array(5)] with 6 elements

```
OUTPUT 714;"PROG:SElected:NUMBER? Array"  
ENTER 714;Result_array(*)
```

**or**

```
OUTPUT 714;"PROG:NUMB? Array"  
ENTER 714;Result_array(*)
```

In this example, the array named Result\_array(\*) in the ENTER statement must be dimensioned exactly the same as the array named Array in the IBASIC program.

---

**NOTE**

Individual array elements cannot be queried with the :NUMBER? command.

### Example querying the value of a one dimensional array whose name is known but whose current size is unknown

```
10 DIM Temp$[5000] !This will hold 250 numbers @ 20 characters each  
20 DIM Result_array(500) !This array will hold up to 501 values  
30 OUTPUT 714;"PROG:NUMB? Array" !Query the desired array  
40 ENTER 714;Temp$ !Enter the values into a temporary string variable  
50 N=-1 !Initialize array pointer, assume option base 0  
60 REPEAT !Start loop to take values from string and put in array  
70 N=N+1 !Increment array pointer  
80 Pos_comma=POS(Temp$,",") !Find comma separator  
90 Result_array(N)=VAL(Temp$[1,Pos_comma-1]) !Put value into array  
100 Temp$=Temp$[Pos_comma+1] !Remove value from temporary string  
110 UNTIL POS(Temp$,",")=0 !Check for last value in temporary string  
120 Result_array(N+1)=VAL(Temp$) !Put last value into array  
130 END
```

The above example assumes that the dimensioned size of the IBASIC array is smaller than the dimensioned size of the array named Result\_array.

---

**NOTE**

Individual array elements cannot be queried with the :NUMBER? command.

**:STATe RUN | PAUSE | STOP | CONTINUE** . The STATe command is used to set, from an external controller, the execution state of the IBASIC program in the Test Set. [Table 8-3](#) defines the effect of setting the execution state of the IBASIC program to a desired state from each of the possible current states.

**Table 8-3 Effect of STATe Commands**

Desired State of IBASIC Program (STATe command sent to Test Set)	Current State of IBASIC Program		
	RUNNING	PAUSED	STOPPED
RUN	HP-IB Error: -221 Settings conflict	RUNNING	RUNNING
CONT	HP-IB Error: -221 Settings conflict	RUNNING	HP-IB Error: -221 Settings conflict
PAUSE	PAUSED	PAUSED	STOPPED
STOP	STOPPED	STOPPED	STOPPED

The program execution states are defined as follows:

- **RUNNING**, the program is currently executing.
- **PAUSED**, the program has reached a break in execution but can be continued.
- **STOPPED**, program execution has been terminated.

**Syntax**

PROGram[:SElected]:STATe RUN|PAUSE|STOP|CONTINUE

**Example**

OUTPUT 714; "PROGram:SElected:STATe RUN"

or

OUTPUT 714; "PROG:STAT RUN"

**:STATE?**. The STATE? query command is used to query, from an external controller, the current execution state of the IBASIC program in the Test Set. The return data (RUN, STOP, or PAUS) is sent as a series of ASCII characters.

The program execution states are defined as follows:

- RUN, the program is currently executing.
- PAUS, the program has reached a break in execution but can be continued.
- STOP, program execution has been terminated.

### Syntax

```
PROGram[:SElected]:STATe?
```

### Example

```
OUTPUT 714; "PROGram:SElected:STATe?"
```

```
ENTER 714;State$
```

**or**

```
OUTPUT 714; "PROG:STAT?"
```

```
ENTER 714;State$
```

**:STRing <varname>{,<svalues>}** . The :STRing command is used to set, from an external controller, the value of string variables or string arrays in an IBASIC program in the Test Set. <varname> is the name of an existing string variable or string array in the IBASIC program. <svalues> is a list of comma-separated quoted strings which are used to set the value of <varname>.

---

**NOTE**

If the variable name <var\_name> is longer than 12 characters it must be sent as string data (<var\_name> enclosed in quotes). For example, OUTPUT 714;"PROG:STR 'Var\_name','data'".

Attempting to send a <var\_name> longer than 12 characters as character data (<var\_name> *not* enclosed in quotes) will generate the following error: HP-IB Error: -112 Program mnemonic too long.

If you want to append the IBASIC "\$" string identifier onto the string variable name, the string variable name must be sent as string data, that is enclosed in quotes. For example, OUTPUT 714;"PROG:STR 'Var\_name\$', 'data' "

Appending the IBASIC "\$" string identifier onto the string variable name without enclosing the string variable name in quotes will generate HP-IB Error: -101 Invalid character.

---

If an attempt is made to set the value of a string variable or array and no IBASIC program is in the Test Set an IBASIC Error: -282 Illegal program name is generated. If an attempt is made to set the value of a string variable or array and the string variable specified in <varname> does not exist in the program an IBASIC Error: -283 Illegal variable name is generated. If a quoted string value is too long to fit into the string variable then it is silently truncated when stored into the IBASIC string variable. If the specified string variable cannot hold all of the quoted strings an IBASIC Error: -108 Parameter not allowed is generated.

**Syntax**

PROGram[:SElected]:STRing <varname>{,<svalues>}

**Example setting the value of a simple string variable**

OUTPUT 714;"PROGram:SElected:STRing Variable,'data' "

**or**

OUTPUT 714;"PROG:STR Variable,'data' "

**Example of setting the value of a string array with 3 elements of 5 characters each, such as Array\$(2)[5]**

OUTPUT 714;"PROGram:SElected:STRing Array,'12345','12345','12345' "

**or**

OUTPUT 714;"PROG:STR Array,'12345','12345','12345' "

---

**NOTE**

With Option Base 0 set in IBASIC, array indexing starts at 0.

**:STRing? <varname>** . The :STRing? query command is used to return, to an external controller, the current value of string variables or arrays in an IBASIC program in the Test Set. <varname> is the name of an existing string variable or string array in the IBASIC program.

---

**NOTE**

If the variable name <var\_name> is longer than 12 characters it must be sent as string data (<var\_name> enclosed in quotes). For example, OUTPUT 714;"PROG:STR? 'Var\_name'".

Attempting to send a <var\_name> longer than 12 characters as character data (<var\_name> *not* enclosed in quotes) will generate the following error:

```
HP-IB Error: -112 Program mnemonic too long
```

If you want to append the IBASIC '\$' string identifier onto the string variable name, the string variable name must be sent as string data, that is enclosed in quotes. For example,

```
OUTPUT 714;"PROG:STR? 'Var_name$' "
```

Appending the IBASIC '\$' string identifier onto the string variable name without enclosing the string variable name in quotes will generate the following error: HP-IB Error: -101 Invalid character.

---

For simple string variables the value is returned as a quoted string ("This is an example."). For string arrays the values are returned as a comma separated list of quoted strings ("This is an example.", "This is an example."). The string array elements are returned in ascending order (Array\$(0), Array\$(1), Array\$(2), etc.).

If an attempt is made to query the value of a string variable or array and no IBASIC program is in the Test Set an IBASIC Error: -283 Illegal variable name is generated. If an attempt is made to query the value of a string variable or array and the string variable specified in <varname> does not exist in the program an IBASIC Error: -283 Illegal variable name is generated.

**Syntax**

```
PROGram[:SElected]:STRing? <varname>
```

---

**NOTE**

The program commands and syntax used to enter string data from the Test Set into the external controller will depend upon the programming language used in the external controller. The examples which follow represent the capabilities of HP Rocky Mountain BASIC programming language running on an HP 9000/300 Series Controller.

---

### Example of querying the value of a simple string variable

```
OUTPUT 714;"PROG:SElected:STRing? Variable"
ENTER 714;Value$
```

**or**

```
OUTPUT 714;"PROG:STR? Variable"
ENTER 714;Value$
```

### Example of querying the value of a string array with 3 elements of 5 characters each, such as Array\$(2)[5]

```
OUTPUT 714;"PROG:SElected:STRing? Array"
ENTER 714 USING "3(X,5A,2X)";Result_array$(*)
```

**or**

```
OUTPUT 714;"PROG:STR? Array"
ENTER 714 USING "3(X,5A,2X)";Result_array$(*)
```

This example assumes that the string array named Result\_array\$(\*) is dimensioned exactly the same as the array named Array in the IBASIC program and that each element in the string array Array has five characters in it.

### Example of querying the value of a string array whose name is known but whose current size is unknown

```
05 OPTION BASE 1
10 DIM Temp$(5000) !This will hold 5000 characters
20 DIM Temp_array$(50)[200]!Temp array: 50 elements of 200 character
30 OUTPUT 714;"PROG:STR? Array" !Query the desired array
40 ENTER 714;Temp$ !Enter the values into a temporary string variable
50 N=0 !Initialize array pointer
60 EPEAT !Start loop to take values from string and put in array
70 N=N+1 !Increment array pointer
80 Pos_comma=POS(Temp$,",") !Find comma separator
90 Temp_array$(N)=Temp$[2,Pos_comma-2] !Put value into array
100 Temp$=Temp$[Pos_comma+1] !Remove value from temporary string
110 UNTIL POS(Temp$,",")=0 !Check for last value in temporary string
120 Temp_array$(N+1)=Temp$[2,LEN(Temp$)-1]!Put last value in array
130 END
```

The above example assumes that the total number of characters in the dimensioned size of the IBASIC string array named Array is smaller than the dimensioned size of the string variable named Temp\$. Also, the maximum length of any element in the IBASIC string array Array must be less than or equal to 200 characters.

**:WAIT.** The :WAIT command stops the Test Set from executing any commands or queries received through HP-IB until after the IBASIC program exits the RUN state; that is, the program is either PAUSED or STOPPED.

---

**CAUTION**

The Test Set will continue to process HP-IB commands into the HP-IB input buffer up to the point that the buffer is full. If the external controller attempts to send more commands than can fit into the HP-IB input buffer before the IBASIC program is PAUSED or STOPPED, the HP-IB bus will appear to be locked up. This is due to the fact that the HP-IB bus and the external controller will be in a temporary holdoff state while waiting for the HP-IB input buffer to empty.

If a query command is sent to the Test Set while the IBASIC program is under the influence of a :WAIT command, no data will be put into the Test Set's Output Queue until the IBASIC program is either PAUSED or STOPPED. If the external controller attempts to enter the queried data before the IBASIC program is PAUSED or STOPPED, the HP-IB bus will appear to be locked up. This is due to the fact that the HP-IB bus and the external controller will be in a temporary holdoff state while waiting for the data to be put into the Output queue to satisfy the enter command.

---

**Syntax**

```
PROGram[ :SElected]:WAIT
```

**Example**

```
OUTPUT 714; "PROGram:SElected:WAIT"
```

**or**

```
OUTPUT 714; "PROG:WAIT"
```



**:WAIT?.** The :WAIT? query command stops the Test Set from executing any commands or queries received through HP-IB until after the IBASIC program exits the RUN state, that is - the program is either PAUSED or STOPPED. A 1 is returned in response to the :WAIT? query command when the IBASIC program is either stopped or paused.

---

**CAUTION**

When the :WAIT? query command is sent to the Test Set the program running on the external controller will hang on the enter or input statement until the IBASIC program is either STOPPED or PAUSED. This is due to the fact that the HP-IB bus and the external controller will be in a temporary holdoff state while waiting for the Test Set to put a 1 into the Output queue to satisfy the :WAIT? query command.

---

**Syntax**

PROGram[:SELEcted]:WAIT?

**Example**

```
OUTPUT 714;"PROGram:SELEcted:WAIT?"
ENTER 714;Dummy
```

**or**

```
OUTPUT 714;"PROG:WAIT?"
ENTER 714;Dummy
```

Consider the following example where the user wishes to determine, from an external controller, if the IBASIC program running on the Test Set has finished executing. The example programs show how this might be accomplished with and without using the :WAIT? query command.

**Example BASIC program without using the :WAIT? query command**

```
10 OUTPUT 714;"PROG:STAT RUN"
20 LOOP
30 OUTPUT 714;"PROG:STAT?"
40 ENTER 714;State$
50 EXIT IF State$="STOP" OR State$="PAUS"
60 END LOOP
70 DISP "IBASIC program not running."
80 END
```

**Example BASIC program using the :WAIT? query command**

```
10 OUTPUT 714;"PROG:STAT RUN"
20 OUTPUT 714;"PROG:WAIT?"
30 ENTER 714;Dummy !Program will hang here until IBASIC program stops
40 DISP "IBASIC program not running."
50 END
```

## Using the EXECute Command

The PROG:EXECute command can be used to list, edit and control IBASIC programs in the Test Set from an external controller. This eliminates having to use the cursor control knob and provides a more efficient way of making small changes to programs. The full range of IBASIC program commands can be executed from an external controller using the PROG:EXECute command.

The following operations are given as typical examples of using the PROG:EXECute command.

---

### NOTE

The program commands and syntax used to send data from the external controller to the Test Set will depend upon the programming language used in the external controller. The examples which follow represent the capabilities of HP Rocky Mountain BASIC programming language running on an HP 9000/300 Series Controller.

When a PROG:EXECute command is sent to the Test Set through HP-IB from an external controller the Test Set is put into REMOTE mode. The Test Set must be put in LOCAL mode to use the front panel keys or to use the serial ports to input data into the IBASIC Command line.

---

### Entering a new IBASIC program line

IBASIC program lines can be entered directly into the Test Set's RAM memory, one line at a time, from an external controller using the PROG:EXECute command as follows:

#### Example

```
PROG:EXEC '<new program line number/program line>'
```

where <new program line number/program line> represents a valid IBASIC program line.

For example, to enter the following new program line into the Test Set,

#### Example

```
20 A=3.14
```

execute the following command from the external controller:

#### Example

```
OUTPUT 714;"PROG:EXEC '20 A=3.14'"
```

Quoted strings, such as those used in PRINT commands, must use double quotes. For example,

#### Example

```
OUTPUT 714;"PROG:EXEC '30 PRINT ""TEST""'"
```

## Editing an existing IBASIC program line

Existing IBASIC program lines which are resident in the Test Set's RAM memory can be edited, one line at a time, from an external controller using the PROGRAM:EXECute command as follows:

### Example

```
PROG:EXEC '<existing program line number/modified program line>'
```

where <existing program line number/modified program line> represents an existing IBASIC program line.

For example, to edit the following existing program line in the Test Set.

### Example

```
30 OUTPUT 814;"AFAN:DEMP:GAIN 20 dB"
```

to

```
30 OUTPUT 814;"AFAN:DEMP:GAIN 10 dB"
```

execute the following command from the external controller:

### Example

```
OUTPUT 714;"PROG:EXEC '30 OUTPUT 814;"AFAN:DEMP:GAIN 10 dB"'"
```

Quoted strings, such as those used in OUTPUT commands, must use double quotes.

## Listing A Program

Execute the following command on the external controller to list an IBASIC program which is resident in the Test Set to the currently specified IBASIC Controller LIST device.

### Example

```
OUTPUT 714;"PROG:EXEC 'LIST'"
```

## Downloading An IBASIC Program Into the Test Set

The following procedure uses the PROGram Subsystem commands to transfer an IBASIC program, which is resident in the memory of the external controller, from the external controller to the Test Set. This procedure assumes the Test Set's HP-IB address is set to 14. The example also assumes the external controller is an HP 9000 Series 300 Controller.

1. Access the Test Set's TESTS (IBASIC Controller) screen.
2. Enter a program into the external controller. Use the sample program below if no program is available. When run, the sample program clears the Test Set's IBASIC controller display area, and prints a message indicating that the download procedure worked.

### Example

```
10 !THIS IS A SAMPLE PROGRAM
20 CLEAR SCREEN
30 PRINT "DOWNLOADING COMPLETED"
40 END
```

3. Execute the following commands on the external controller:

### Example

```
OUTPUT 714; "PROG:DEL:ALL"
OUTPUT 714; "PROG:DEF #0"
LIST #714
OUTPUT 714; " "END
```

4. To verify that the program was downloaded, execute the following commands from the external controller:

### Example

```
OUTPUT 714; "PROG:EXEC 'LIST' "
```

The program should be listed on the Test Set's TESTS (IBASIC Controller) screen.

5. Run the program on the Test Set by first selecting the LOCAL key on the front panel of the Test Set and then selecting the RUN key on the Test Set's TESTS (IBASIC Controller) screen.

## Uploading a Program From the Test Set

The following BASIC program copies an IBASIC program from the Test Set's IBASIC Controller RAM to the external controller and then stores it to a file on the external controller's currently assigned mass storage device.

When the upload program is entered and run on the external controller, the operator is prompted for the name of the file to store the IBASIC program in. As the upload program is running, the total number of characters in the program, and the number of characters transferred, are displayed.

### Example

```

10 !Upload an IBASIC program in Test Set to an external controller.
20 DIM Prog_line$[200] !Holds longest program line in Test Set
30 DIM File_name$[10] !Holds the name of file to store IBASIC program
40 Addr=714 !Test Set HP-IB address
50 LINPUT "Enter name of file to store IBASIC program in:",File_name$
60 OUTPUT Addr;"PROG:DEF?"
70 ENTER Addr USING "X,D,#";Count_length !Get length of count field
80 !Get number of characters in program, includes CR/LF on each line
90 ENTER Addr USING VAL$(Count_length)&"D,#";Chars_total
100 !Create ASCII file to hold program, add 5 records for buffer
110 CREATE ASCII File_name$,(Chars_total/256)+5
120 ASSIGN @File TO File_name$
130 LOOP
140 ENTER Addr;Prog_line$ !Read in one program line
150 OUTPUT @File;Prog_line$ !Store in file
160 Chars_xferd=Chars_xferd+LEN(Prog_line$)+2 !CR/LF not read
170 DISP Chars_xferd;"of";Chars_total;"characters transferred."
180 EXIT IF Chars_xferd>=Chars_total
190 END LOOP
200 ENTER Addr;Msg_terminator$ !Terminate the block data transfer
210 ASSIGN @File TO * !Close the file
220 END

```

## **Saving an IBASIC Program To A PC card**

The following procedure can be used to save an IBASIC program from the IBASIC Controller's RAM memory to a PC card inserted into the front panel of the Test Set.

1. Press **Local**, **Shift**, **Cancel** on the Test Set to perform an IBASIC reset.
2. If the PC card has not been initialized, insert it into the Test Set and execute the following command on the external controller:

### **Example**

```
OUTPUT 714;"PROG:EXEC 'INITIALIZE" ":INTERNAL,4" "' "
```

**or**

```
OUTPUT 714;"PROG:EXEC 'INITIALIZE" "DOS:INTERNAL,4" "' "
```

3. Insert the initialized PC card into the Test Set.
4. Define the PC card as the Mass Storage device by executing the following command on the external controller:

### **Example**

```
OUTPUT 714;"PROG:EXEC 'MSI " ":INTERNAL,4" "' "
```

5. Save the program to the PC card by executing the following command on the external controller:

### **Example**

```
OUTPUT 714;"PROG:EXEC 'SAVE "<filename>" "' "
```

---

## The TESTS Subsystem

The Test Set makes available to the user an automated user-interface which has been specifically designed for radio test. One of the primary problems associated with automated radio testing is the need to rapidly configure the software with the information needed to test a specific type of radio. Information such as, test frequencies/channels, test specifications, test parameters, test conditions and pass/fail limits. Most often the test(s) and test procedure(s) used to test a class of radio (AM, FM, AMPS, TACS, TDMA, CDMA, etc.) are defined by an industry standard and are used to test all radio types within that class. However, for a specific radio type, the test(s) may remain the same but the information needed to test the radio changes. For example, a portable hand-held may have different transmit power levels than a mobile - the RF power test is the same but the power levels, supply voltages, pass/fail limits etc. can be different.

There are two approaches which can be used to provide the software with the information needed to test a radio: a) hardcode the information directly into the software, or b) store the information outside the program code itself and make it available to the software as needed. Hardcoding the information into the software has several serious drawbacks: changing the information is difficult and the software becomes specific to that radio type. Storing the information outside the program code and making it available to the software as needed overcomes both of these problems, that is - the information is easy to change and the software is not specific to a particular type of radio.

The Test Set's automated user-interface was designed using this approach. Hewlett-Packard has developed software specifically designed to run on the Test Set. HP Test Software provides the user with a library of industry standard tests. All radio specific information has been removed from the software. The information needed to test a specific type of radio is available to the user through the TESTS Subsystem. To generate, change and maintain this radio specific information the TESTS Subsystem provides menu driven input screens to define specifications, parameters, test sequencing and system configuration for a particular radio type.

## Writing Programs For the TESTS Subsystem

The HP 83224A IBASIC Developer's Tool Kit for Windows is required for developing programs which use the Tests Subsystem. Contact your local Hewlett-Packard sales representative or sales office for ordering and pricing information.

## TESTS Subsystem File Descriptions

Three types of files are used in the TESTS Subsystem to store different types of information.

### Code Files

The first aspect of an automated definition is the code itself. This is just a standard IBASIC code file that can reside either on the PC card, or in an internal RAM. The name of this file has a *.PGM* extension. This extension identifies the file as program code.

### Library Files

A Library indicates all of the available test subroutines in the code, the set of all parameters that might be entered using the user-interface screens, and all specifications that might be used by the subroutines in the code to decide if a test point passes or fails.

Only one Library is defined for each Code file. The name of this file has a *.LIB* file extension in the Test Set, indicating that this is a Library file. Also, both the Library and Code file should have the same base name to indicate the relationship between them.

A Library is required to use the user-interface screen functions of the TESTS Subsystem. If the program is simple enough that there is no need for user-input, or if all the user-input is simple enough to be accomplished with INPUT statements, a [NO LIB] option is available.

### Procedure Files

A Procedure allows the user to define which of the test subroutines, parameters, and specifications defined in the Library will be used to test a specific Radio. There may be many Procedures defined that use the same IBASIC Code and Library, each using a different subset of the choices available in the Library. These files have a *.PRC* file extension, but are *not* required to have the same base name as either the Library or the Code. The name of the corresponding Library (if any) is stored in each Procedure file.



**Figure 8-5 TESTS Subsystem File Relationship**

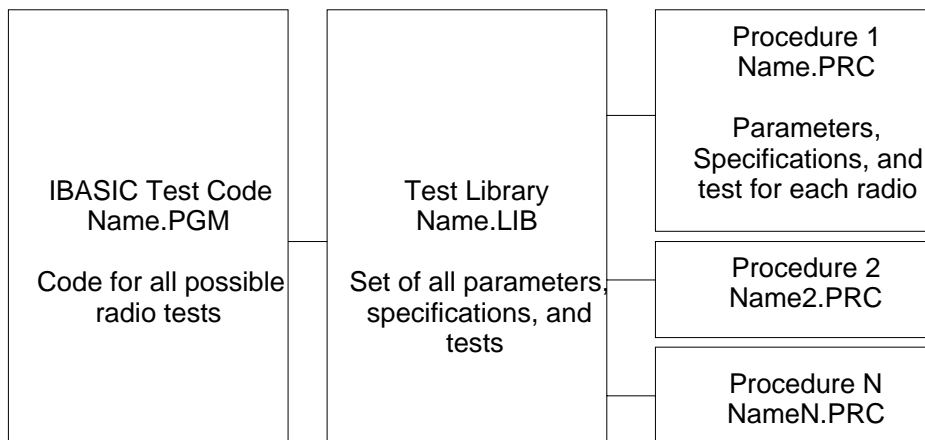

ch6drw06.ds4

## TESTS Subsystem Screens

The TESTS Subsystem uses several screens to create, select, and copy files, and to run tests.

### The Main TESTS Subsystem Screen (SOFTWARE MENU)

Refer to [Figure 8-6](#).

The SOFTWARE MENU screen is accessed by pressing the front panel TESTS key. Test procedures are selected and run from this screen. Additionally, access to all other TESTS Subsystem screens is accomplished from this screen.

The `Select Procedure Location:` field is used to select the mass storage location for the procedure to be loaded. The `Select Procedure Filename:` field is used to select the name of the procedure to be loaded. The `Description:` field gives the user a brief description of the procedure currently selected in the `Select Procedure Filename:` field.

To view all the procedures available on the mass storage location currently selected in the `Select Procedure Location:` field, position the cursor on the `Select Procedure Filename:` field and push the rotary knob. A menu will appear in the lower right corner of the screen, displaying all the procedure files which are available. This is not a listing of the full contents of the selected mass storage location, it is only a list of the procedures files that are stored on that media.

**Figure 8-6** The SOFTWARE MENU Screen

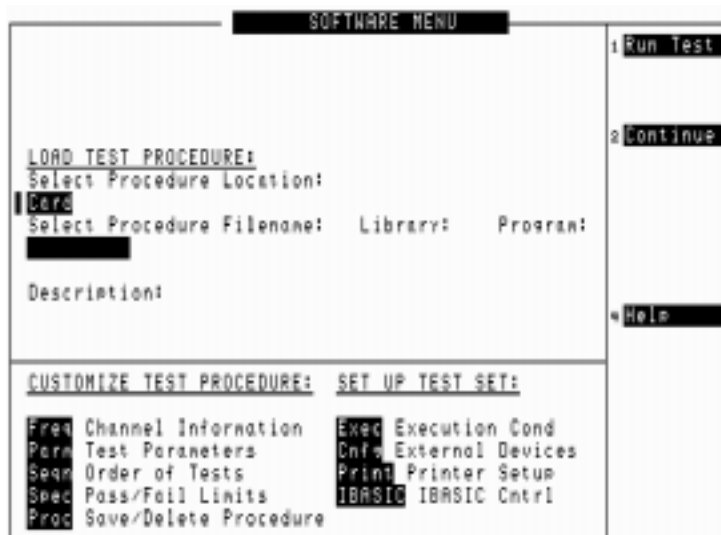

ch6dr7.pcx

## TESTS Subsystem User-Interface Screens

The TESTS Subsystem allows the user to easily modify the test subroutines, parameters, specifications and configuration to correspond to the requirements of a specific radio. There are several user-interface screens provided to allow the user to make modifications.

To access any of these screens, position the cursor on the desired field and push the rotary knob.

- The *Order of Tests* screen lets the user select the desired test(s) from the full set of available tests in the loaded procedure file.
- The *Channel Information* screen defines the transmit and receive frequencies used for the selected tests.
- The *Pass/Fail Limits* screen defines the specifications used to generate pass/fail messages during testing.
- The *Test Parameters* screen is used to define instrument settings and characteristics to match those of the radio being tested (audio load impedance, audio power, power supply voltage).
- The *External Devices* screen identifies all connected HP-IB equipped instruments and their HP-IB addresses.
- The *Save/Delete Procedure* screen is used to save or delete Procedures.
- The *Printer Setup* screen is used to select the printer used for IBASIC PRINT commands and to configure the format of the printer page.
- The *Execution Cond* screen is used to configure the IBASIC program execution conditions.
- The *IBASIC Cntrl* screen is the IBASIC Controllers display screen.

The use of the *IBASIC Controller* screen is described in the beginning of this chapter.



---

## **9** **Error Messages**

## General Information About Error Messages

Information concerning error messages displayed by the Test Set may be found in one of the following manuals:

- *HP 8935 Series E6380A CDMA/PCS Cellular Base Station Test Set and E6381A TDMA Base Station Test Set Programmer's Guide* (this manual)
- *Test Set's Assembly Level Repair Manual*
- *HP Instrument BASIC User's Handbook*:
- *A Beginner's Guide to SCPI*

The format of the displayed message determines which manual contains information about the error message. There are four basic error message formats:

- Positive numbered error messages
- IBASIC error messages
- HP-IB error messages
- Text only error messages

The following paragraphs give a brief description of each message format and direct you to the manual to look in for information about error messages displayed in that format.

### Positive Numbered Error Messages

Positive numbered error messages are generally associated with IBASIC. Refer to the *HP Instrument BASIC User's Handbook* for information on IBASIC error messages.

Positive numbered error messages take the form:

ERROR XX

**For example:**

Error 54 Duplicate file name

or

Error 80 in 632 Medium changed or not in drive

## IBASIC Error Messages

IBASIC Error Messages are associated with IBASIC operation. IBASIC error messages can have both positive and negative numbers. Refer to the *HP Instrument BASIC User's Handbook* for information on positive numbered error messages. Refer to the [“Numbered HP-IB Error Descriptions” on page 303](#) for a list of the negative numbered error messages (the error message associated with a negative number is the same for HP-IB errors and IBASIC errors).

**IBASIC error messages take the form:**

IBASIC Error: -XX

For example:

IBASIC Error: -286 Program runtime error

## HP-IB Error Messages

HP-IB Error Messages are associated with HP-IB operation. Refer to “[Numbered HP-IB Error Descriptions](#)” on page 303 for a list of HP-IB error messages.

HP-IB error messages take the form:

```
HP-IB Error: -XX
```

or

```
HP-IB Error
```

For example:

```
HP-IB Error: -410 Query INTERRUPTED.
```

or

```
HP-IB Error: Input value out of range.
```

Usually, negative numbers preceding the error messages text correspond to the error conditions outlined in the Standard Commands for Programmable Instruments (SCPI). For more information on SCPI, order the following book,

*A Beginner's Guide to SCPI* Addison-Wesley Publishing Company ISBN 0-201-56350-9 HP P/N 5010-7166

or contact,

Fred Bode, Executive Director SCPI Consortium

8380 Hercules Drive, Suite P3

La Mesa, CA 91942

Phone: (619) 697-8790, FAX: (619) 697-5955 CompuServe Number:

76516,254

## Text Only Error Messages

Text only error messages are generally associated with manual operation of the Test Set. This manual contains information on text only error messages.

Text only error messages can also be displayed while running the Test Set's built-in diagnostic or calibration utility programs. Refer to the *Assembly Level Repair* manual for information on text only error messages displayed while running the Test Set's built-in diagnostic or calibration utility programs.

Text only error messages take the form:

```
This is an error message.
```

**Example**

```
Input value out of range.
```



## The Message Display

During instrument operation, various messages may appear on the Test Set's display. Prompt-type messages generally appear on the first line of the Test Set's display. General operating and error messages usually appear on the second line of the display. Some messages are persistent; they remain displayed until the error condition no longer exists, or until another persistent message with greater priority occurs. Other messages are only displayed when the error first occurs; they are removed when a key is pressed or the knob is turned, or when an HP-IB command is received. Many of the messages are displayed on the ERROR MESSAGE screen until the instrument is turned off.

Messages that are about error conditions may tell you what to do to correct the error (turn something off, reduce a field's value, press a certain key, and so forth). Messages and prompts are sometimes accompanied by a beep or warble.

---

NOTE

### Warbles and Beeps

A warble sound indicates that an instrument-damaging event is occurring. Beeps often occur only with the first occurrence of the message. Prompts are generally silent.

---

## Non-Recoverable Firmware Error

The non-recoverable firmware error is very important. It appears when an unanticipated event occurs that the Test Set's firmware cannot handle. The message appears in the center of the Test Set's display and (except for the two lines in the second paragraph) has the form:

### Example

```
Non-recoverable firmware error. Please record the 2 lines of
text below and contact Hewlett-Packard through your local
service center or by calling (800) 827-3848 (USA, collect) and
asking to speak to the Service Engineer.
```

```
'Address error exception'
  at line number 0
```

To continue operation, turn POWER off and back on.

Follow the instructions in the message.

Unfortunately, you will not be able to recover from this condition. You must switch the Test Set off and back on. When you rerun the test where the Error Message occurred, it may not occur again. If it does reappear, it would be helpful to Hewlett-Packard to record exactly what the configuration of the instrument was when the error appeared and contact Hewlett-Packard.

## Text Only Error Messages

Operation errors generally occur when you try to do something the Test Set was not designed to do. Most messages tell you what to do to correct the problem, (turn something off, reduce a field's value, press a certain key,...and so forth).

Some common messages are listed here:

- All self tests passed.
- The Test Set did not detect any hardware or firmware failures during its initial self-diagnostics.

This message should always be displayed immediately after instrument turn on.
- Input value out of range.

A number was entered that was too large or small for the selected field, for example, trying to set `AFG1 Freq` to 125 kHz.
- Invalid keystroke.

You used a key that has no function relating to the selected field, for example, pressing the `On/Off` key while the `Filter 1` field is selected.
- Option not installed.

You selected a function that requires optional hardware that is not present.
- Turn off either AM or FM settings.

You tried to create simultaneous AM and FM (using any combination of `AFGen1`, `AFGen2`, and the `Mod In To` field). The Test Set does not provide simultaneous AM and FM.
- Squelch interrupt overflow. Reset using `Meas Reset` (press and release the `Shift` key, then the `Hold` key).

The Test Set temporarily interrupts audio measurements when squelch is first broken to prevent internal switching transients from influencing measurements (except when using the `SCOPE`, `SPEC ANL`, `SERVICE` screens). If squelch is repetitively broken in a period of a few seconds, the duration of measurement interruption becomes too great, and the Test Set stops interrupting the signal. Following measurements may be influenced by transient signals.

`Meas Reset` clears the data buffer used to generate interrupts, resetting the normal squelch operation to eliminate transients.

This condition may occur when monitoring low-level off-the-air signals.

- Cal file checksum incorrect - initializing file.

This error usually occurs after changing the Test Set's firmware ROM's. It is not a problem in that instance, but should not re-appear during subsequent operation of the Test Set.
- One or more self tests failed. Error code: XXXX

An instrument failure was detected when the Test Set was turned on. (For example, having a stuck front-panel key during turn on.) The numbered error message corresponds to a binary-weighted group of errors listed in the ["\\*TST? \(Self-Test Query\)"](#) on page 92.
- Change Ref Level, Input Port or Attenuator (if using Hold).

The RF signal level is either too great or too small for the current input port, attenuator setting, or both. This error often occurs when trying to make a low-level measurement using the RF IN/OUT port with the spectrum analyzer. Make the indicated changes until this message is no longer displayed.
- Change RF Gen Amplitude, Output Port or Atten Hold (if on).

This message appears when the RF Generator's Amplitude field is set too high when using the RF IN/OUT port or when adjusting the amplitude with the Atten Hold field set to On.
- The RF IN/OUT port has a lower maximum output level than the DUPLEX OUT port. Use the DUPLEX OUT port, or reduce the RF generator's level.

If Atten Hold is On, you may be adjusting the amplitude outside of the allowed range. Change the amplitude
- Direct latch write occurred. Cycle power when done servicing.
  - The SERVICE screen was accessed and one or more internal latch settings were changed. Turn the instrument off and back on to reset the latches. (This condition can occur during periodic calibration.)

## **HP-IB Errors**

Most HP-IB errors occur when the control program attempts to query a measurement that is not currently available, or tries to access an instrument connected to the external HP-IB without configuring the Test Set as the System Controller. When diagnosing the cause of an error condition check for these conditions first.

---

## Text Only HP-IB Errors

Un-numbered (text only) HP-IB error messages are generally self-explanatory. For example, trying to retrieve a saved register that does not exist generates the following error message:

```
HP-IB Error: Register does not exist.
```

The following list contains a subset of the Test Set's text only HP-IB error messages. These messages represent error conditions which may require explanation in addition to the error message text.

```
HP-IB Error during Procedure catalog. Check Config.
```

This error occurs when the Test Set fails to access an external HP-IB disk drive when trying to obtain a catalog of procedure files. This would occur when the `Select Procedure Location:` field on the SOFTWARE MENU screen is set to `Disk` and the operator then tries to select a procedure filename using the `Select Procedure Filename:` field. Ensure that the `Mode` field on the I/O CONFIGURE screen is set to `Control` and that the `External Disk Specification` field on the TESTS (External Devices) screen has the correct mass storage volume specifier for the external disk drive.

```
HP-IB Query Error. Check instrument state.
```

This message usually appears when the control program queries a measurement that is not currently available (on the currently displayed screen and in the ON state), such as querying the TX Frequency measurement when TX Freq Error is displayed.

This message may also be immediately followed by the message,

```
HP-IB Error: -420: Query UNTERMINATED.
```

```
HP-IB Error: Not Enough Memory Available for Save.
```

This message will be generated when the control program tries to save the current Test Set state into a Save/Recall register using the REG:SAVE commands, but there is insufficient memory available in the Test Set. The Test Set's non-volatile RAM is shared by the following resources:

- IBASIC programs
- Save/Recall registers
- RAM (internal)

In order to save the current Test Set state into a Save/Recall register more non-volatile RAM will have to be made available. This can be done by,

- reducing the size of the IBASIC program
- deleting one or more existing Save/Recall registers
- recovering RAM space

The ROM utility RAM\_USAGE will display the total amount of non-volatile RAM installed in the Test Set, the RAM allocation, the Save/Recall register allocation and the amount of non-volatile RAM available to IBASIC.

HP-IB Error: Unknown Save/Recall error.

This error can occur on a Test Set when trying to SAVE the instrument state to a mass storage device with a LIF formatted media. The default file system for the Test Set is DOS. Refer to [“Default File System” on page 198](#) for more details.

HP-IB Error: HP-IB Units cause invalid conversion of attr.

This error is generated when trying to change Attribute Units and one of the Data Function values is set to zero. If this error is encountered the programmer must change the Data Function settings to values that can be converted to the new units\_of\_measure. Refer to [“Attribute Units \(AUNits\)” on page 76](#) for more details.

---

## Numbered HP-IB Error Descriptions

The following HP-IB errors can be generated under any of the following conditions:

- controlling the Test Set with an IBASIC program running on the built-in IBASIC controller
- controlling HP-IB devices/instruments, connected to the Test Set's external HP-IB bus, with an IBASIC program running on the built-in IBASIC controller
- controlling the Test Set with a program running on an external controller
- using the Test Set manually to print to an external HP-IB printer
- using the Test Set manually to access procedure/library/code files stored on an external HP-IB disk

---

### NOTE

HP-IB Parser.

The term "Parser" is used in the following error message descriptions. It refers to the Test Set's HP-IB command parser.

---

#### Error -100

Command error

This code indicates only that a Command Error as defined in *IEEE 488.2, 11.5.1.1.4* has occurred.

#### Error -101

Invalid character

A syntactic element contains a character which is invalid for that type.

#### Error -102

Syntax error

An unrecognized command or data type was encountered; for example, a string value was received when the *device* does not accept strings.

**Error –103**

Invalid separator

The parser was expecting a separator and encountered an illegal character. For example, the colon used to separate the **FREQ** and **AMPL** commands should be omitted in the following command:

```
RFQ:FREQ 850 MHZ
```

```
:
```

```
;AMPL -35
```

**Error –104**

Data type error

The parser recognized a data element different than one allowed. For example, numeric or string data was expected but block data was encountered.

**Error –105**

GET not allowed

A Group Execute Trigger was received within a program message (see *IEEE 488.2, 7.7*).

**Error –108**

Parameter not allowed

More parameters were received than expected for the header. For example, the **\*ESE** common command only accepts one parameter; receiving **\*ESE 36,1** is not allowed.

**Error –109**

Missing parameter

Fewer parameters were received than required for the header. For example, the **\*ESE** common command requires one parameter; receiving **\*ESE** is not allowed.

**Error –110**

Command header error

An error was detected in the header.

**Error –111**

Header separator error

A character which is not a legal header separator was encountered while parsing the header.



**Error -112**

Program mnemonic too long

The header contains more than twelve characters (see IEEE 488.2, 7.6.1.4).

**Error -113**

Undefined header

The header is syntactically correct, but it is undefined for this specific *device*. For example, \*XYZ is not defined for any *device*.

**Error -114**

Header suffix out of range

Indicates that a nonheader character has been encountered in what the parser expects is a header element.

**Error -120**

Numeric data error

This error, as well as errors -121 through -128, are generated when parsing a data element which appears to be numeric, including the nondecimal numeric types.

**Error -121**

Invalid character in number

An invalid character for the data type being parsed was encountered. For example, an alpha in a decimal numeric or a “9” in octal data.

**Error -123**

Exponent too large

The magnitude of the exponent was larger than 32000 (see IEEE 488.2, 7.7.2.4.1).

**Error -124**

Too many digits

The mantissa of a decimal numeric data element contained more than 255 digits excluding leading zeros (see IEEE 488.2, 7.7.2.4.1).

**Error -128**

Numeric data not allowed

A legal numeric data element was received, but the *device* does not accept one in this position for the header.

**Error –130**

Suffix error

This error, as well as errors –131 through –138, are generated when parsing a suffix.

**Error –131**

Invalid suffix

The suffix does not follow the syntax described in *IEEE 488.2 7.7.3.2*, or the suffix is inappropriate for this *device*.

**Error –134**

Suffix too long

The suffix contained more than 12 characters (see *IEEE 488.2, 7.7.3.4*).

**Error –138**

Suffix not allowed

A suffix was encountered after a numeric element which does not allow suffixes.

**Error –140**

Character data error

This error, as well as errors –141 through –148, are generated when parsing a character data element.

**Error –141**

Invalid character data

Either the character data element contains an invalid character or the particular element received is not valid for the header.

**Error –144**

Character data too long

The character data element contains more than twelve characters (see *IEEE 488.2, 7.7.1.4*).

**Error –148**

Character data not allowed

A legal character data element was encountered where prohibited by the *device*.

**Error –150**

String data error

This error, as well as errors –151 through –158, are generated when parsing a string element.

**Error -151**

Invalid string data

A string data element was expected, but was invalid for some reason (see *IEEE 488.2, 7.7.5.2*). For example, an END message was received before the terminal quote character.

**Error -152**

Parity error

Parity error

**Error -158**

String data not allowed

A string data element was encountered but was not allowed by the *device* at this point in parsing.

**Error -160**

Block data error

This error, as well as errors -161 through -168, are generated when parsing a block data element.

**Error -161**

Invalid block data

A block data element was expected, but was invalid for some reason (see *IEEE 488.2 7.7.6.2*). For example, an END message was received before the length was satisfied.

**Error -168**

Block data not allowed

A legal block data element was encountered but was not allowed by the *device* at this point in parsing.

**Error -170**

Expression error

This error, as well as errors -171 through -178, are generated when parsing an expression data element.

**Error -171**

Invalid expression

The expression data element was invalid (see *IEEE 488.2, 7.7.7.2*); for example, unmatched parentheses or an illegal character.

**Error –178**

Expression data not allowed

A legal expression data was encountered but was not allowed by the *device* at this point in parsing.

**Error –180**

Macro error

This error, as well as errors –181 through –184, are generated when defining a macro or executing a macro.

**Error –181**

Invalid outside macro definition

Indicates that a macro parameter placeholder was encountered outside of a macro definition.

**Error –183**

Invalid inside macro definition

Indicates that the program message unit sequence, sent with a \*DDT or \*DMC command, is syntactically invalid.

**Error –184**

Macro parameter error

Indicates that a command inside the macro definition had the wrong number or type of parameters.

**Error –200**

Execution error

This code indicates only that an Execution Error as defined in *IEEE 488.2, 11.5.1.1.5* has occurred.

**Error –201**

Invalid while in local

Indicates that a command is not executable while the *device* is in local due to a hard local control (see *IEEE 488.2, 5.6.1.5*). For example, a *device* with a rotary switch receives a message which would change the switches state, but the *device* is in local so the message can not be executed.

**Error –202**

Settings lost due to rtl

Indicates that a setting associated with a hard local control (see *IEEE 488.2, 5.6.1.5*) was lost when the *device* changed to LOCS from REMS or to LWLS from RWLS.

**Error -210**

Trigger error

**Error -211**

Trigger ignored

Indicates that a GET, \*TRG, or triggering signal was received and recognized by the device but was ignored because of device timing considerations. For example, the device was not ready to respond.

**Error -212**

Arm ignored

Indicates that an arming signal was received and recognized by the *device* but was ignored.

**Error -213**

Init ignored

Indicates that a request for a measurement initiation was ignored as another measurement was already in progress.

**Error -214**

Trigger deadlock

Indicates that the trigger source for the initiation of a measurement is set to GET and subsequent measurement query is received. The measurement cannot be started until a GET is received, but the GET would cause an INTERRUPTED error.

**Error -215**

Arm deadlock

Indicates that the arm source for the initiation of a measurement is set to GET and subsequent measurement query is received. The measurement cannot be started until a GET is received, but the GET would cause an INTERRUPTED error.

**Error -220**

Parameter error

Indicates that a program data element related error occurred.

**Error -221**

Settings conflict

Indicates that a legal program data element was parsed but could not be executed due to the current device state (see *IEEE 488.2, 6.4.5.3 and 11.5.1.1.5*).

**Error –222**

Data out of range

Indicates that a legal program data element was parsed but could not be executed because the interpreted value was outside the legal range as defined by the *device* (see *IEEE 488.2, 11.5.1.1.5*).

**Error –223**

Too much data

Indicates that a legal program data element of block, expression, or string type was received that contained more data than the device could handle due to memory or related device-specific requirements.

**Error –224**

Illegal parameter value

Used where exact value, from a list of possibles, was expected.

**Error –230**

Data corrupt or stale

Possibly invalid data; new reading started but not completed since last access.

**Error –231**

Data questionable

Indicates that measurement accuracy is suspect.

**Error –240**

Hardware error

Indicates that a legal program command or query could not be executed because of a hardware problem in the *device*.

**Error –241**

Hardware missing

Indicates that a legal program command or query could not be executed because of missing *device* hardware. For example, an option was not installed.

**Error –250**

Mass storage error

Indicates that a mass storage error occurred.

**Error -251**

Missing mass storage

Indicates that a legal program command or query could not be executed because of missing mass storage. For example, an option that was not installed.

**Error -252**

Missing media

Indicates that a legal program command or query could not be executed because of a missing media. For example, no disk.

**Error -253**

Corrupt media

Indicates that a legal program command or query could not be executed because of corrupt media. For example, bad disk or wrong format.

**Error -254**

Media full

Indicates that a legal program command or query could not be executed because the media was full. For example, there is no room on the disk.

**Error -255**

Directory full

Indicates that a legal program command or query could not be executed because the media directory was full.

**Error -256**

File name not found

Indicates that a legal program command or query could not be executed because the file name on the device media was not found. For example, an attempt was made to read or copy a nonexistent file.

**Error -257**

File name error

Indicates that a legal program command or query could not be executed because the file name on the device media was in error. For example, an attempt was made to copy to a duplicate file name.

**Error -258**

Media protected

Indicates that a legal program command or query could not be executed because the media was protected. For example, the write-protect switch on a memory card was set.

### Error –260

Expression error

Indicates that an expression program data element related error occurred.

### Error –261

Math error in expression

Indicates that a syntactically legal expression program data element could not be executed due to a math error. For example, a divide-by-zero was attempted.

### Error –270

Macro error

Indicates that a macro-related execution error occurred.

### Error –271

Macro syntax error

Indicates that a syntactically legal macro program data sequence, according to *IEEE 488.2, 10.7.2*, could not be executed due to a syntax error within the macro definition (see *IEEE 488.2, 10.7.6.3*).

### Error –272

Macro execution error

Indicates that a syntactically legal macro program data sequence could not be executed due to some error in the macro definition (see *IEEE 488.2, 10.7.6.3*).

### Error –273

Illegal macro label

Indicates that the macro label defined in the *\*DMC* command was a legal string syntax, but could not be accepted by the *device* (see *IEEE 488.2, 10.7.3 and 10.7.6.2*). For example, the label was too long, the same as a common command header, or contained invalid header syntax.

### Error –274

Macro parameter error

Indicates that the macro definition improperly used a macro parameter placeholder (see *IEEE 488.2, 10.7.3*).

### Error –275

Macro definition too long

Indicates that a syntactically legal macro program data sequence could not be executed because the string of block contents were too long for the device to handle (see *IEEE 488.2, 10.7.6.1*).



**Error -276**

Macro recursion error

Indicates that a syntactically legal macro program data sequence could not be executed because the device found it to be recursive (see *IEEE 488.2 10.7.6.6*).

**Error -277**

Macro redefinition not allowed

Indicates that syntactically legal macro label in the \*DMC command could not be executed because the macro label was already defined (see *IEEE 488.2, 10.7.6.4*).

**Error -278**

Macro header not found

Indicates that a syntactically legal macro label in the \*GMC? query could not be executed because the header was not previously defined.

**Error -280**

Program error

Indicates that a downloaded program-related execution error occurred.

**Error -281**

Cannot create program

Indicates that an attempt to create a program was unsuccessful. A reason for the failure might include not enough memory.

**Error -282**

Illegal program name

The name used to reference a program was invalid. For example, redefining an existing program, deleting a nonexistent program, or in general, referencing a nonexistent program.

**Error -283**

Illegal variable name

An attempt was made to reference a nonexistent variable in a program.

**Error -284**

Program currently running

Certain operations dealing with programs are illegal while the program is running. For example, deleting a running program is not possible.

**Error -285**

Program syntax error

Indicates that syntax error appears in a downloaded program.

**Error –286**

Program runtime error

**Error –300**

Device-specific error

This code indicates only that a Device-Dependent Error as defined in *IEEE 488.2, 11.5.1.1.6* has occurred.

**Error –310**

System error

Indicates that some error, termed “system error” by the device, has occurred.

**Error –311**

Memory error

Indicates that an error was detected in the *device's* memory.

**Error –312**

PUD memory lost

Indicates that the protected user data saved by the \*PUD command has been lost.

**Error –313**

Calibration memory lost

Indicates that nonvolatile calibration data used by the \*CAL? command has been lost.

**Error –314**

Save/recall memory lost

Indicates that the nonvolatile data saved by the \*SAV command has been lost.

**Error –315**

Configuration memory lost

Indicates that nonvolatile configuration data saved by the *device* has been lost.

**Error –330**

Self-test failed

**Error –350**

Queue overflow

This code indicates that there is no room in the queue and an error occurred but was not recorded. This code is entered into the queue in lieu of the code that caused the error.

#### Error –400

Query error

This code indicates only that a Query Error as defined in *IEEE 488.2 11.5.1.1.7 and 6.3* has occurred.

#### Error –410

Query INTERRUPTED

Indicates that a condition causing an INTERRUPTED Query error occurred (see *IEEE 488.2, 6.3.2.3*). For example, a query followed by DAB or GET before a response was completely sent.

This message appears when you query a measurement without immediately entering the returned value into a variable. For example, the following program lines query the TX Frequency measurement and enter its value into a variable (Rf\_freq):

```
OUTPUT 714;"MEAS:RFR:FREQ:ABS?"  
ENTER 714;Rf_freq
```

#### Error –420

Query UNTERMINATED

Indicates that a condition causing an UNTERMINATED Query error occurred (see *IEEE 488.2, 6.3.2.2*). For example, the *device* was addressed to talk and an incomplete program message was received.

This message usually appears when trying to access a measurement that is not active. For example, you cannot query the TX Frequency measurement when the TX Freq Error measurement is displayed.

#### Error –430

Query DEADLOCKED

Indicates that a condition causing a DEADLOCKED Query error occurred (see *IEEE 488.2, 6.3.1.7*). For example, both input buffer and output buffer are full and the device cannot continue.

#### Error –440

Query UNTERMINATED after indefinite response

Indicates that a query was received in the same program message after a query requesting an indefinite response was executed (see *IEEE 488.2, 6.5.7.5.7*).

**Error –606**

Update of Input Module Relay Switch Count file failed.

Indicates that the Test Set was not able to update the Input Module Relay Switch Count EEPROM file with the current switch count data from the non-volatile RAM switch count array. This error is most probably generated as a result of a hardware error or failure. Refer to the Test Set's *Assembly Level Repair* for diagnostic information.

**Error –607**

Checksum of Non-Volatile RAM Relay Count data bad.

Indicates that the Test Set was not able to generate the proper checksum for the Input Module Relay Switch Count data from the non-volatile RAM switch count array. This error is most probably generated as a result of a hardware error or failure. Refer to the Test Set's for diagnostic information.

**Error –608**

Initialization of Input Module Relay Count file failed.

Indicates that the Test Set was not able to initialize the Input Module Relay Switch Count EEPROM file during installation of a new input module. This error is most probably generated as a result of a hardware error or failure. Refer to the Test Set's for diagnostic information.

**Error –1301**

Handoff attempted while not in Connect state.

Indicates that an attempt was made to handoff a mobile station to a new voice channel when the Call Processing Subsystem was not in the Connect state.

**Error -1302**

Release attempted while not in Connect state.

Indicates that an attempt was made to send a Release message to a mobile station when the Call Processing Subsystem was not in the Connect state.

**Error -1303**

Page attempted while not in Active state.

Indicates that an attempt was made to Page a mobile station when the Call Processing Subsystem was not in the Active state.

**Error -1304**

Origination attempted while not in Active state.

Indicates that a mobile station attempted to originate a call to the simulated Base Station when the Call Processing Subsystem was not in the Active state.

**Error -1305**

Registration attempted while not in Active state.

Indicates that an attempt was made to send a Registration message to a mobile station when the Call Processing Subsystem was not in the Active state.

**Error -1306**

Origination in progress.

Indicates that an attempt was made to; register, page, handoff, release, order a change in power level, put the mobile station in maintenance mode, or send an alert message to the mobile station while an origination was in progress.

**Error -1307**

Timeout occurred while attempting to register Mobile.

Indicates that the simulated Base Station's internal timer expired before receiving a response from the mobile station during a registration attempt. The internal timer is set to 20 seconds when the Register state is entered.

**Error -1308**

Timeout occurred while attempting to page Mobile.

Indicates that the simulated Base Station's internal timer expired before receiving a response from the mobile station during a page attempt. The internal timer is set to 20 seconds when the Page state is entered.

#### **Error –1309**

Timeout occurred while attempting to access Mobile.

Indicates that the simulated Base Station's internal timer expired before receiving a response from the mobile station during an access attempt. The internal timer is set to 20 seconds when the `Access` state is entered.

#### **Error –1310**

Timeout occurred while attempting to alert Mobile.

Indicates that the simulated Base Station's internal timer expired before receiving a response from the mobile station during an alert attempt. The internal timer is set to 20 seconds when the alert order is sent to the mobile station.

#### **Error –1311**

RF power loss indicates loss of Voice Channel.

When any Call Processing Subsystem screen is displayed (except the `ANALOG MEAS` screen) and the Call Processing Subsystem is in the `Connect` state, the host firmware constantly monitors the mobile station's transmitted carrier power. If the power falls below 0.0005 Watts the simulated Base Station will terminate the call and return to the `Active` state. This error message is displayed if the host firmware has detected that the mobile station's carrier power has fallen below the 0.0005 Watts threshold. The call is dropped and the Call Processing Subsystem returns to the `Active` state.

#### **Error –1312**

Data from RVC contains invalid bits in word [1,2,3].

Indicates that the decoded data received on the reverse voice channel contains invalid bits in word 1 and/or word 2 and/or word 3. The raw decoded data is displayed in hexadecimal format in the top right-hand portion of the `CALL CONTROL` screen. Raw decoded data is only displayed when the `CALL CONTROL` screen `Display` field is set to `Data`.

#### **Error –1313**

Timeout occurred while in Maintenance state.

Indicates that the simulated Base Station's internal timer expired before the mobile station was taken out of the maintenance state. The internal timer is set to 20 seconds when the maintenance order is sent to the mobile station.

#### **Error -1314**

Alert attempted while not in Maintenance or Connect state.

**Indicates that an attempt was made to send an Alert order to the mobile station when the Call Processing Subsystem was not in the Maintenance state or Active state.**

#### **Error -1315**

Data from RECC contains invalid bits in word [1,2,3].

**Indicates that the decoded data received on the reverse control channel contains invalid bits in word 1 and/or word 2 and/or word 3. The raw decoded data is displayed in hexadecimal format in the top right-hand portion of the CALL CONTROL screen. Raw decoded data is only displayed when the CALL CONTROL screen Display field is set to Data.**

#### **Error -1316**

Incomplete data received on RECC for word [1,2,3].

**Indicates that the decoded data received on the reverse control channel did not contain the proper number of bits in word 1 and/or word 2 and/or word 3. The raw decoded data is displayed in hexadecimal format in the top right-hand portion of the CALL CONTROL screen. Raw decoded data is only displayed when the CALL CONTROL screen Display field is set to Data.**

#### **Error -1317**

Incomplete data received on RVC for word [1,2,3].

**Indicates that the decoded data received on the reverse voice channel did not contain the proper number of bits in word 1 and/or word 2 and/or word 3. The raw decoded data is displayed in hexadecimal format in the top right-hand portion of the CALL CONTROL screen. Raw decoded data is only displayed when the CALL CONTROL screen Display field is set to Data.**





---

## Symbols

\*CLS, 99  
\*ESE, 100  
\*ESE?, 100  
\*ESR?, 100  
\*IDN?, 89  
\*OPC, 93  
\*OPC?, 95  
\*OPT?, 90  
\*PCB, 101, 189  
\*RCL, 101  
\*RST, 91, 182  
\*SAV, 101  
\*SRE, 100, 171  
\*SRE?, 100, 171  
\*STB, 100  
\*STB?, 126  
\*TRG, 100  
\*TST?, 92  
\*WAI, 98  
.LIB Files, 205, 288  
.PGM Files, 205, 288  
.PRC Files, 205, 288  
.SAV Files, 205  
: (colon), 67  
; (semicolon), 67, 118  
:: (semicolon, colon), 68, 119  
? (question mark), 68  
' ' (single quotes), 66

## A

Active Controller, 34, 187, 188  
Active Measurement, 32  
AdvanceLink (HP 68333F Version  
B.02.00) terminal emulator,  
235, 250  
Annunciators, 33  
Arming Measurements, 112  
ASCII Text Files  
  sending with ProComm  
  Communications Software,  
  257  
  sending with Windows  
  Terminal, 256  
Attribute Units, 76  
  changing, 77  
  definition, 76  
  guidelines, 81  
  querying, 80  
AUNits, 76  
  *See Also* Attribute Units  
AUNits?, 80  
Autoranging  
  affect on measurement speed,  
  114  
Avoiding Program Hangs, 30, 52

## B

Backing up files, 214  
Battery, PC Card  
  part numbers, 212  
Battery, PC Cards  
  replacing, 212

## C

Calibration Status Register  
  Group, 152  
  accessing registers contained in, 154  
  condition register bit assignments, 152  
Changing a Field Setting, 36  
\*CLS, 99  
Code Files, 204, 205, 288  
Colons, 67  
Common Commands, 88  
  CLS, 99  
  ESE, 100  
  ESE?, 100  
  ESR?, 100  
  IDN, 89  
  OPC, 93  
  OPC?, 95  
  OPT?, 90  
  PCB, 101  
  RCL, 101  
  RST, 91, 182  
  SAV, 101  
  SRE, 100  
  SRE?, 100  
  STB?, 100, 126  
  TRG, 100, 104  
  TST?, 92  
  WAI, 98  
Communicate Status Register  
  Group, 164  
  accessing registers contained in, 166  
  condition register bit assignments, 164  
Controller, External, 22, 35  
COPY command, 215, 216  
COPY\_PL, 214  
Copying a volume, 216  
Copying files, 215

## D

Data Functions  
  querying ON/OFF state, 82  
  turning ON and OFF, 82  
DB-9 jack, 226  
DCL command, 184  
Default File System, 198  
Device Clear (DCL), 184  
Display Units, 70  
  changing, 70  
  guidelines, 72  
  querying, 72  
Display, Locking, 120  
DOS File Names, 205  
DOS File System, 205  
Downloading Programs to Test Set, 245, 284  
DUNits, 70  
  *See Also* Display Units  
DUNits?, 72

## E

EPSON card. *See* PC Cards  
Error Message Queue Group, 146  
  accessing the error message queue, 147  
Error Messages, 293, 294  
  operation, 298  
  types of, 293  
\*ESE, 100  
\*ESE?, 100  
\*ESR?, 100  
Example Programs  
  AUNits, limits, meter, reference, 79  
  change settings, 36  
  download ASCII program to Test Set, 255  
  download IBASIC program to Test Set, 268  
  I/O to two serial ports, 261  
  identification query (\*IDN?), 89  
  make measurement, draw scope trace, 84  
  make settings, read results, 29  
  make simple measurement, 38  
  operation complete (\*OPC), 94  
  option identification query (\*OPT?), 90  
  polling standard event register (\*ESR), 94  
  query settings or results, 37  
  querying AUNits, 80  
  run, pause, stop, 275  
  self test query (\*TST?), 92  
  service request (\*SRE), 94  
  status byte (\*STB), 127  
  strings, 277  
  timeouts, MAV, 58  
  timeouts, ON TIMEOUT, 54  
  triggering, immediate, 108  
  triggering, repetitive/single, 109  
  triggering, settling, 109  
  upload IBASIC code from Test Set, 246  
  upload IBASIC program from Test Set, 269  
  variables and arrays, 271  
  wait (\*WAI), 98  
Extended Addressing, 41  
External Automatic Control Mode, 22  
External Controller, 18, 22, 35

---

## F

File Names  
  conflicts, 206  
  recommendations, 207  
File Naming Conventions, 205  
File Types, 207  
Files  
  backing up, 214  
  copying, 215  
Flash ROM, 213  
Front Panel Functions,  
  non-programmable, 39

## G

Gate Time  
  affect on measurement speed,  
    116  
GET, 104  
Group Execute Trigger (GET),  
  104

## H

Hangs, 30, 52  
Hardware Status Register #1  
  Group, 160  
  accessing registers contained in,  
    162  
  condition register bit  
    assignments, 160  
Hardware Status Register #2  
  Group, 156  
  accessing registers contained in,  
    158  
  condition register bit  
    assignments, 156  
HP-IB  
  configuration, 34  
  external (select code 7), 21, 35  
  getting started, 26  
  internal (select code 8), 21, 35  
  standards, 26  
  using, 17  
HP-IB Address  
  displaying, 41  
  factory setting, 41  
  setting, 41  
HP-IB Common Commands, 88  
  CLS, 99  
  ESE, 100  
  ESE?, 100  
  ESR?, 100  
  IDN, 89  
  OPC, 93  
  OPC?, 95  
  OPT?, 90  
  PCB, 101  
  RCL, 101  
  RST, 91, 182  
  SAV, 101  
  SRE, 100  
  SRE?, 100  
  STB?, 100, 126  
  TRG, 100, 104  
  TST, 92  
  WAI, 98  
HP-IB Error Messages, 293  
HP-IB Errors, 300  
HP-IB Units  
  changing, 74  
  definition, 73  
  guidelines, 75  
  querying, 74

---

## I

IBASIC Command Line, 222  
IBASIC Controller, 21  
  default mass storage location, 202  
  HP-IB interface, 21, 35  
  overview, 18  
  programming language, 20  
  screen, 221  
  serial port interface, 226  
IBASIC EDIT Mode, 249  
IBASIC Error Messages, 293  
IBASIC Language, 20  
IBASIC Program Development, 223  
\*IDN?, 89  
IEEE 488 2  
  Common Commands  
    OPT?, 90  
IEEE 488.1  
  compliance, 39, 40  
  Interface Function Capabilities, 40  
  Remote Interface Message Capabilities, 42  
  SRQ, 168  
IEEE 488.2  
  compliance, 39, 40  
  Output Queue, 144  
  Overlapped commands, 64  
  Sequential commands, 64  
  Standard Event Status Register, 138  
  Status Byte Register, 124  
IEEE 488.2 Common Commands  
  CLS, 99  
  ESE, 100, 143  
  ESE?, 100, 142  
  ESR?, 100, 141  
  IDN, 89  
  list of, 88  
  OPC, 93  
  OPC?, 95  
  PCB, 101  
  RCL, 101  
  RST, 91, 182  
  SAV, 101  
  SRE, 100  
  SRE?, 100  
  STB?, 100, 126  
  TRG, 100, 104  
  TST?, 92  
  WAI, 98

IFC command, 186  
Increasing Measurement Speed, 114  
  autoranging, 114  
  combining ENTER statements, 119  
  combining OUTPUT statements, 118  
  compound commands, 117  
  gate time, 116  
  measurement setup time, 117  
  screen display time, 120  
  speed of control program, 117  
Initialization  
  Device Clear (DCL) Command, 184  
  front panel Preset key, 181  
  Interface Clear (IFC) Command, 186  
  methods of (for Test Set), 178  
  power on reset, 179  
  RST Common Command, 182  
  Selected Device Clear (SDC)  
    HP-IB Bus Command, 185  
    Test Set, 177  
INITIALIZE command, 207, 218  
Interface Clear (IFC), 186  
Internal Automatic Control Mode, 20, 23

## K

keys, front panel, 39

---

## L

- .LIB Files, [288](#), [205](#)
- Library Files, [205](#), [288](#)
  - backing up, [214](#)
- Local Lockout, [50](#)
- Local Mode, [48](#)
- Local to Remote Transition, [49](#)
- Local/Remote Triggering
  - Changes, [107](#)
- Lock Up, HP-IB, [106](#), [112](#)
- Locking the Display Screen, [120](#)

## M

- Manual Control Mode, [19](#), [23](#)
- Mass Storage Devices, [197](#)
  - accessing, [204](#)
  - default locations, [202](#)
  - initializing media for, [207](#), [218](#)
  - overview, [198](#)
  - PC cards, [201](#), [209](#)
  - RAM, [200](#), [217](#)
  - ROM, [200](#), [208](#)
  - selecting, [203](#)
  - write protecting, [211](#)
- Mass Storage Locations
  - default values, [202](#)
  - selecting, [203](#)
- Mass Storage Volume Specifier (MSI), [213](#)
- MAV command, [58](#)
- Measurement Pacing, [112](#)
- Measurement Speed, Increasing, [114](#)
- Measurements
  - active, [19](#), [32](#)
  - ON TIMEOUT, [54](#)
  - querying ON/OFF state, [82](#)
  - querying results, [52](#)
  - querying value, [68](#)
  - recommended sequence, [28](#)
  - timeouts (MAV), [58](#)
  - turning ON and OFF, [82](#)
- Memory Card. *See* PC Cards
- Message
  - error, [293](#), [294](#)
  - operation, [298](#)
  - types of, [294](#)
- Microsoft® Windows Terminal
  - terminal emulator, [231](#), [249](#)
- MSI command, [213](#)
- Multiple Addressing, [41](#)

## N

- Non-programmable Functions, [39](#)

## O

ON TIMEOUT command, 54  
ON/OFF key, 82  
\*OPC, 93  
\*OPC?, 95  
Operating Modes  
  external automatic control, 18, 22  
  internal automatic control, 18, 20, 23  
  manual control, 18, 19, 23  
Operation Complete (\*OPC), 93  
Operation Messages, 298  
Operation Status Register Group, 134  
  accessing registers contained in, 136  
  Condition Register bit assignments, 135  
\*OPT?, 90  
Optimization, 114  
OTP card. *See* PC Cards  
Output Queue Group, 144  
  accessing the output queue, 145  
Overlapped Commands, 64

## P

Pacing, Measurements, 112  
Passing Control, 187  
  example programs, 192  
  passing control back  
    automatically, 190  
  passing control back to another controller, 190  
  passing control back using PASS CONTROL, 190  
  passing control to Test Set, 189  
  requesting control from IBASIC, 191  
PC  
  Serial Port Configuration, 230  
PC Cards  
  address, 213  
  battery, 212  
  Flash ROM, 213  
  initializing, 207, 213  
  inserting and removing, 210  
  mass storage volume specifier, 213  
  OTP, 213  
  overview, 197  
  part numbers, 209  
  SRAM, 213  
  types of, 198  
  write-protect switch, 211  
\*PCB, 101  
PCMCIA card. *See* PC Cards  
.PGM Files, 288, 205  
Polling Standard Event Status Register (\*ESR?), 94  
.PRC Files, 288, 205  
Preset key, 181  
Printer  
  connecting to HP-IB, 34  
Procedure Files  
  accessing, 204  
  backing up, 214  
  description, 288  
  naming conventions, 205  
ProCommr® Revision 2.4.3  
  terminal emulator, 250  
Program Development  
  choosing development method, 238  
  IBASIC, 224  
  methods of, 224  
  using external computer, 240  
  using IBASIC EDIT mode, 247  
  using word processor on PC, 251  
Program Hangs  
  avoiding, 30, 52

PROGram Subsystem  
  commands, 266  
  downloading programs, 245  
  executing commands, 282  
  overview, 263  
Programming Examples  
  AUNits, limits, meter, reference, 79  
  change settings, 36  
  download ASCII program to Test Set, 255  
  download IBASIC program to Test Set, 268  
  I/O to two serial ports, 261  
  identification query (\*IDN?), 89  
  make measurement, draw scope trace, 84  
  make settings, read results, 29  
  make simple measurement, 38  
  operation complete (\*OPC), 94  
  option identification query (\*OPT?), 90  
  polling standard event register (\*ESR), 94  
  query settings or results, 37  
  querying AUNits, 80  
  run, pause, stop, 275  
  self test query (\*TST?), 92  
  service request (\*SRE), 94  
  status byte (\*STB), 127  
  strings, 277  
  timeouts, MAV, 58  
  timeouts, ON TIMEOUT, 54  
  triggering, immediate, 108  
  triggering, repetitive/single, 109  
  triggering, settling, 109  
  upload IBASIC code from Test Set, 246  
  upload IBASIC program from Test Set, 269  
  variables and arrays, 271  
  wait (\*WAI), 98

---

## Q

Querying Measurement Results,  
19, 52  
Question Mark, 68  
Questionable Data/Signal  
Register Group, 148  
accessing registers contained in,  
150  
condition register bit  
assignments, 148  
Quotation Marks, 66

## R

RAM  
initializing, 218  
mass storage device, 200  
using, 217  
RAM\_MANAGER, 217  
\*RCL, 101  
Reading a Field Setting, 37  
Remote Mode, 48  
Remote Operation, 39  
Remote to Local Transition, 49  
ROM  
mass storage device, 200  
using, 208  
ROM card. *See* PC Cards  
RS232 Port, 226  
\*RST, 91, 182  
Running Programs, 28

## S

\*SAV, 101  
.SAV Files, 205  
Save/Recall File, 205  
Save/Recall Registers  
default mass storage locations,  
202  
SDC command, 185  
Selected Device Clear (SDC), 185  
Selecting Mass Storage Devices,  
203  
Semicolon and Colon, 68, 119  
Semicolons, 67, 118  
Sequential Commands, 64  
Serial Port  
configuration, 228, 260  
input buffer length, 229  
receive/transmit pacing, 229  
select code 10, 226, 260, 262  
select code 9, 226, 228, 260  
serial I/O from IBASIC  
program, 260  
Serial Port Configuration, 226  
Service Request, 94  
Service Request Enable Register,  
170  
clearing, 172  
reading, 171  
writing, 171  
Service Requests, 168  
enabling SRQ interrupts, 168  
procedure for generating, 172  
Service Request Enable  
Register, 170  
setting up SRQ interrupts, 168  
Single Quotes, 31, 66  
Spaces, in Commands, 31, 66  
SPECial  
DISPlay, 120  
DISPlay?, 121  
Speed, increasing, 114  
SRAM card. *See* PC Cards  
\*SRE, 100  
\*SRE?, 100  
SRQ, 168  
Standard Event Status Register  
polling, 94  
Standard Event Status Register  
Group, 138  
accessing registers contained in,  
141  
bit assignments, 141  
STATE  
ON/OFF, 32

STATe command, 82  
STATe?, 82  
Status Byte Register, 124  
  bit assignments, 125, 168  
  clearing, 127  
  reading with serial poll, 126  
  reading with STB Common Command, 126  
  writing, 127  
Status Registers, 133  
Status Reporting, 122  
  Calibration Status Register Group, 152  
  clearing the Status Byte Register, 127  
  Communicate Status Register Group, 164  
  Condition register definition, 129  
  Enable register definition, 130  
  Error Message Queue Group, 146  
  Event register definition, 130  
  Hardware Status Register #1 Group, 160  
  Hardware Status Register #2 Group, 156  
  Operation Status Register Group, 134  
  Output Queue Group, 144  
  Questionable Data/Signal Register Group, 148  
  reading Status Byte Register with serial poll, 126  
  reading Status Byte Register with STB CommonCommand, 126  
  Standard Event Status Register Group, 138  
  Status Byte Register, 124  
  status queue model, 132  
  status register model, 129  
  status register structure overview, 128  
  status registers in Test Set, 133  
  status reporting structure operation, 131  
  structure overview, 122  
  Summary Message definition, 130  
  Transition Filter definition, 129  
  writing the Status Byte Register, 127

\*STB, 100  
\*STB?, 126  
Syntax  
  guidelines, 65  
  SPECial  
    DISPlay, 120  
    DISPlay?, 121  
  TRIGger  
    ABORt, 108  
    IMMediate, 108  
    MODE, 109  
  use of single quotes, 31  
  use of spaces, 31, 66  
  using colons to separate commands, 67  
  using question mark to query setting/field, 68  
  using quotes for strings, 66  
  using semicolon colon command separator, 67, 119  
  using semicolon command separator, 118  
  using semicolon to output multiple commands, 67  
  using upper/lower case letters, 65  
System Controller, 34, 187, 188

**T**  
Terminal Configuration, 237  
Terminal emulator, 230  
TESTS Subsystem, 287  
  default mass storage locations, 203  
  file descriptions, 288  
  file relationships, 289  
  screens, 290  
  writing programs for, 288  
Timeout  
  MAV (message available), 58  
  ON TIMEOUT, 54  
\*TRG, 100  
Trigger  
  aborting, 108  
  commands, 108  
Trigger Event, 104  
Trigger Modes, 105, 109  
  affect on measurement speed, 110, 114  
  default settings, 107  
  local/remote triggering changes, 107  
  retriggering, 105, 109  
  settings for fastest measurements, 110  
  settings for most reliable measurements, 111  
  settling, 106, 109  
Triggering Measurements, 104  
\*TST?, 92



---

## U

UNITs, [73](#)  
  *See Also* HP-IB Units  
units of measure, [69](#)  
UNITs?, [74](#)  
Uploading Programs from Test  
  Set to external controller, [285](#)  
Uploading Programs from Test  
  Set to PC, [259](#)  
Uploading Programs to Test Set,  
  [246](#)

## V

Volume copy, [216](#)

## W

\*WAI, [98](#)  
Wildcards, [216](#)  
Word Processor, [251](#)  
  configuring for program  
  development, [251](#)  
  transferring programs to Test  
  Set, [253](#)  
  writing lines of IBASIC code,  
  [252](#)  
Write-Protect Switch, [211](#)

---

## X

Xon/Xoff, 229